



**US Army Corps
of Engineers**®
New England District
696 Virginia Road
Concord, MA 01742-2751

PUBLIC NOTICE

Comment Period Begins: December 19, 2017
Comment Period Ends: January 19, 2018
File Number: NAE-2017-02083
In Reply Refer To: Cori M. Rose
Phone: (978) 318-8306
E-mail: cori.m.rose@usace.army.mil

The District Engineer has received a permit application to conduct work in waters of the United States from **ATLANTIC CLAM FARMS OF CONNECTICUT, LLC, 71 BYRAM ROAD, #1, GREENWICH, CONNECTICUT 06830**. This work is proposed in waters of Long Island Sound, in an area identified as Payea Reach approximately 3400 feet southeast of Great Captains Island, 980 feet southwest of Island Beach, 4,380 feet west of Green Gong "1", and 6,356 feet east of Red Nun "2". The project is proposed to be undertaken at Department of Agriculture state-issued lease identified as 2016-SW#10/L-481 in the vicinity of NAD83 Latitude 40.98543 N, Longitude -73.60975 W, UTM Zone 18.

The proposed work/gear area is depicted on the attached plans entitled "CT Department of Agriculture, Bureau of Aquaculture, Atlantic Clam Farms, Greenwich, CT SW-10 dated "11/15/2017" and "Atlantic Clam Farms Lot 481 SW#10" dated "November 24, 2017".

The work involves the installation of lines, buoys, anchors and aids to navigation for the commercial cultivation of a winter crop of native sugar kelp (*Saccarina lattissima*). Gear installation at the 4.3 acre area will commence on/after November 1st and the crop harvest and lines will be removed by June 1st of each calendar year. The gear to be deployed will be set in a 600 foot long by 340 foot wide area as described below.

The regulated activities involve the installation of seven (7), 500 foot-long lines anchored at each end and in the middle with concrete anchors, for a total of six (6) anchors per longline and 42 anchors for the entirety of the project. The gear will be set in water depths of 28 to 33 feet mean lower low water (MLLW) and 35 to 40 feet mean high water (MHW). Each anchor line will be attached to a 24-inch surface float with 5/8 inch sinking (vertical) poly rope (for a total of 21, 24-inch buoys). Between the pair of terminal anchors will be affixed a 500 foot-long horizontal seaweed growing line made from 3/8-inch sinking poly line, strung at approximately 5 feet below the water's surface. Along each of the 500 foot-long lines, there will be between 8 and 15, 12-inch diameter black buoys (for a project maximum of 112, 12-inch flotation buoys), to accommodate the weight of the growing seaweed throughout the growing season. There will be a minimum of 40 feet of space between each of the set longlines.

Once the horizontal growing lines are seeded in November, the gear areas will be tended at least once a week. Additionally, once a month each line will be hauled in and checked for warp and headline depth. Buoys will be incrementally added/shifted throughout the growing season to accommodate the increasing weight of the seaweed to ensure adequate buoyancy and line tension. They will be maintained such that there is a minimum clearance of five (5) feet between the growing seaweed and the estuary bottom at MLLW. In addition, the gear area will be marked by six (6) "aid to navigation" buoys that read "DANGER SURFACE GEAR AREA" spaced at a maximum interval of 300 feet, per State of Connecticut Department of Energy and Environmental Protection navigation agency requirement. After the last harvest of the season in May the horizontal long-line gear and buoys will be removed and brought to a land-based facility for inspection and/or

CENAE-R
FILE NO. NAE-2017-02083

repair as needed. The aids to navigation and moorings will remain in the water throughout the year to designate the lease location.

The purpose of the proposed structures is to grow seaweed (kelp) as a harvestable crop for human consumption and commercial distribution.

AUTHORITY

Permits are required pursuant to:

- Section 10 of the Rivers and Harbors Act of 1899
- Section 404 of the Clean Water Act
- Section 103 of the Marine Protection, Research and Sanctuaries Act.

The decision whether to issue a permit will be based on an evaluation of the probable impact of the proposed activity on the public interest. That decision will reflect the national concern for both protection and utilization of important resources. The benefit which may reasonably accrue from the proposal must be balanced against its reasonably foreseeable detriments. All factors which may be relevant to the proposal will be considered, including the cumulative effects thereof; among those are: conservation, economics, aesthetics, general environmental concerns, wetlands, cultural value, fish and wildlife values, flood hazards, flood plain value, land use, navigation, shoreline erosion and accretion, recreation, water supply and conservation, water quality, energy needs, safety, food production and, in general, the needs and welfare of the people.

The Corps of Engineers is soliciting comments from the public; Federal, state, and local agencies and officials; Indian Tribes; and other interested parties in order to consider and evaluate the impacts of this proposed activity. Any comments received will be considered by the Corps of Engineers to determine whether to issue, modify, condition or deny a permit for this proposal. To make this decision, comments are used to assess impacts on endangered species, historic properties, water quality, general environmental effects, and the other public interest factors listed above. Comments are used in the preparation of an Environmental Assessment and/or an Environmental Impact Statement pursuant to the National Environmental Policy Act. Comments are also used to determine the need for a public hearing and to determine the overall public interest of the proposed activity.

ESSENTIAL FISH HABITAT

The Magnuson-Stevens Fishery Conservation and Management Act, as amended by the Sustainable Fisheries Act of 1996 (Public Law 104-267), requires all federal agencies to consult with the National Marine Fisheries Service on all actions, or proposed actions, permitted, funded, or undertaken by the agency, that may adversely affect Essential Fish Habitat (EFH). Essential Fish Habitat describes waters and substrate necessary for fish for spawning, breeding, feeding or growth to maturity.

This project will impact approximately 4.3 acres of Essential Fish Habitat (EFH) that has been designated through the New England & Mid-Atlantic Fishery Management Councils. This habitat consists of subtidal bottom of gravel/gravel-sand in open water of Payea Reach. Temporary obstruction or modification of subtidal habitat may adversely affect species that use these waters and substrate. However, the District Engineer has made a preliminary determination that the site-specific adverse effect will not be substantial. Further consultation with the National Marine Fisheries Service regarding EFH conservation recommendations is being conducted and will be concluded prior to the final decision.

NATIONAL HISTORIC PRESERVATION ACT

Based on his initial review, the District Engineer has determined that little likelihood exists for the proposed work to impinge upon properties with cultural or Native American significance, or listed in, or eligible for listing in, the National Register of Historic Places. Therefore, no further consideration of the requirements of Section 106 of the National Historic Preservation Act of 1966, as amended, is necessary. This determination is based upon one or more of the following:

- a. The permit area has been extensively modified by previous work.
- b. The permit area has been recently created.
- c. The proposed activity is of limited nature and scope.
- d. Review of the latest published version of the National Register shows that no presence of registered properties listed as being eligible for inclusion therein are in the permit area or general vicinity.
- e. Coordination with the State Historic Preservation Officer and/or Tribal Historic Preservation Officer(s)

ENDANGERED SPECIES CONSULTATION

The Corps has reviewed the application for the potential impact on Federally-listed threatened or endangered species and their designated critical habitat pursuant to Section 7 of the Endangered Species Act as amended. It is our preliminary determination that the proposed activity for which authorization is being sought is designed, situated or will be operated/used in such a manner that it is not likely to adversely affect a listed species or their critical habitat. We are coordinating with the NMFS and/or U.S. Fish and Wildlife Service on listed species under their jurisdiction and the ESA consultation will be concluded prior to the final decision.

COASTAL ZONE MANAGEMENT

The States of Connecticut, Maine, Massachusetts, New Hampshire and Rhode Island have approved **Coastal Zone Management Programs**. Where applicable, the applicant states that any proposed activity will comply with and will be conducted in a manner that is consistent with the approved Coastal Zone Management Program. By this Public Notice, we are requesting the State concurrence or objection to the applicant's consistency statement.

The following authorizations have been applied for, or have been, or will be obtained:

- Permit, License or Assent from State.
- Permit from Local Wetland Agency or Conservation Commission.
- Water Quality Certification in accordance with Section 401 of the Clean Water Act.

In order to properly evaluate the proposal, we are seeking public comment. Anyone wishing to comment is encouraged to do so. Comments should be submitted in writing by the above date. If you have any questions, please contact Ms. Cori M. Rose at (978) 318-8306, (800) 343-4789 or (800) 362-4367, if calling from within Massachusetts.

Any person may request, in writing, within the comment period specified in this notice, that a public hearing be held to consider the application. Requests for a public hearing shall specifically state the reasons for holding a public hearing. The Corps holds public hearings for the purpose of obtaining public comments when that is the best means for understanding a wide variety of concerns from a diverse segment of the public.

CENAE-R
FILE NO. NAE-2017-02083

The initial determinations made herein will be reviewed in light of facts submitted in response to this notice. All comments will be considered a matter of public record. Copies of letters of objection will be forwarded to the applicant who will normally be requested to contact objectors directly in an effort to reach an understanding.

THIS NOTICE IS NOT AN AUTHORIZATION TO DO ANY WORK.

Robert J. DeSista
Chief, Permits and Enforcement Branch
Regulatory Division

If you would prefer not to continue receiving Public Notices by email, please contact Ms. Tina Chaisson at (978) 318-8058 or e-mail her at bettina.m.chaisson@usace.army.mil. You may also check here () and return this portion of the Public Notice to: Bettina Chaisson, Regulatory Division, U.S. Army Corps of Engineers, 696 Virginia Road, Concord, MA 01742-2751.

NAME: _____

ADDRESS: _____

PHONE: _____

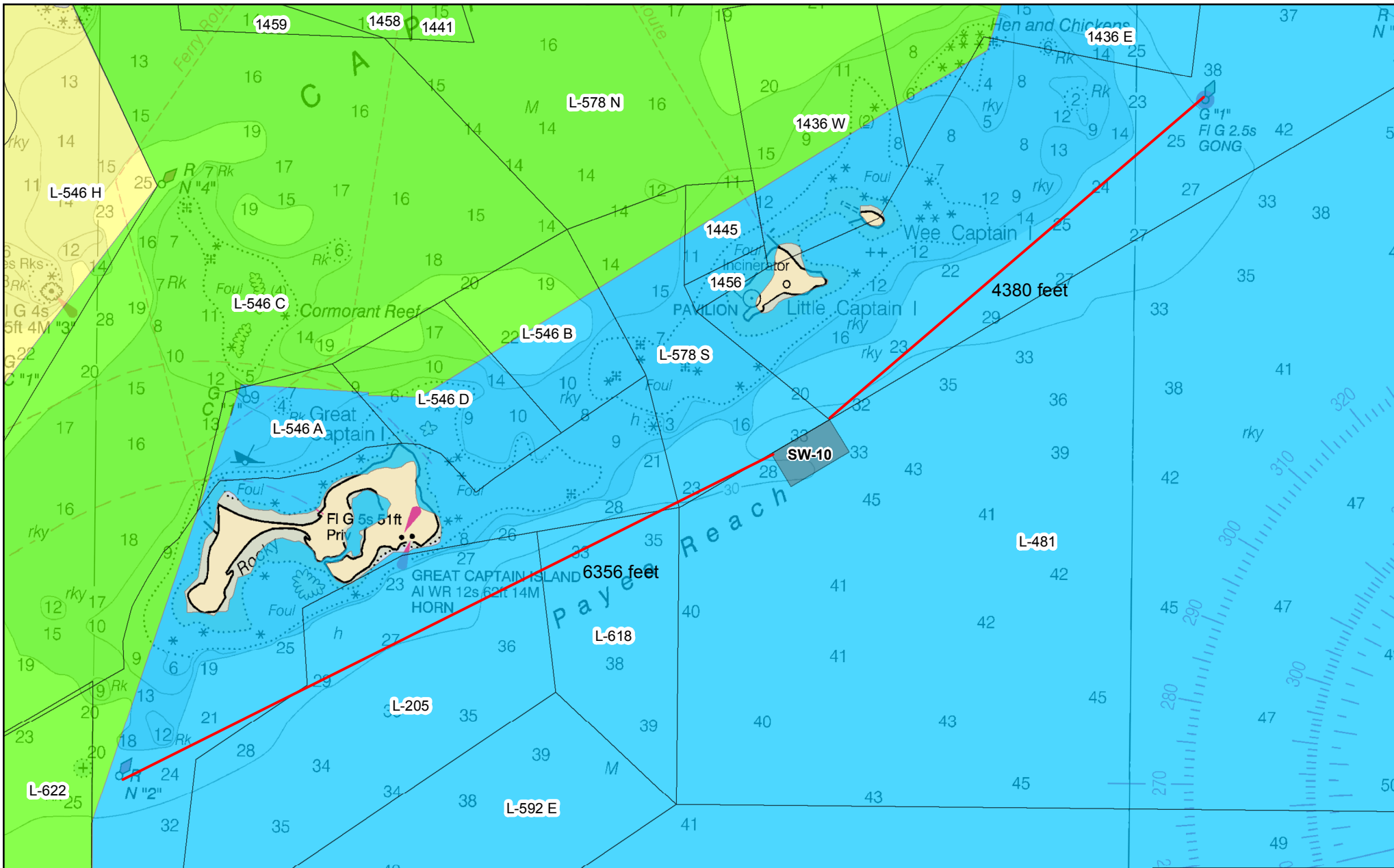

CT Department of Agriculture
 Bureau of Aquaculture Greenwich
 SW-10
 Atlantic Clam Farms

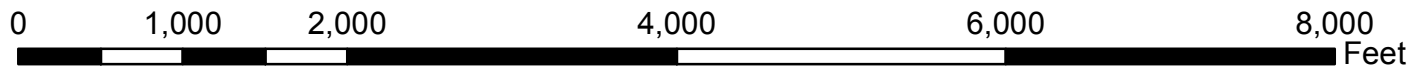

Date: 11/15/2017



Shellfish Classification Area

Classification

- Approved
- Conditionally Approved
- Conditionally Approved Seasonal
- Restricted-Relay
- Conditionally Restricted-Relay
- Prohibited

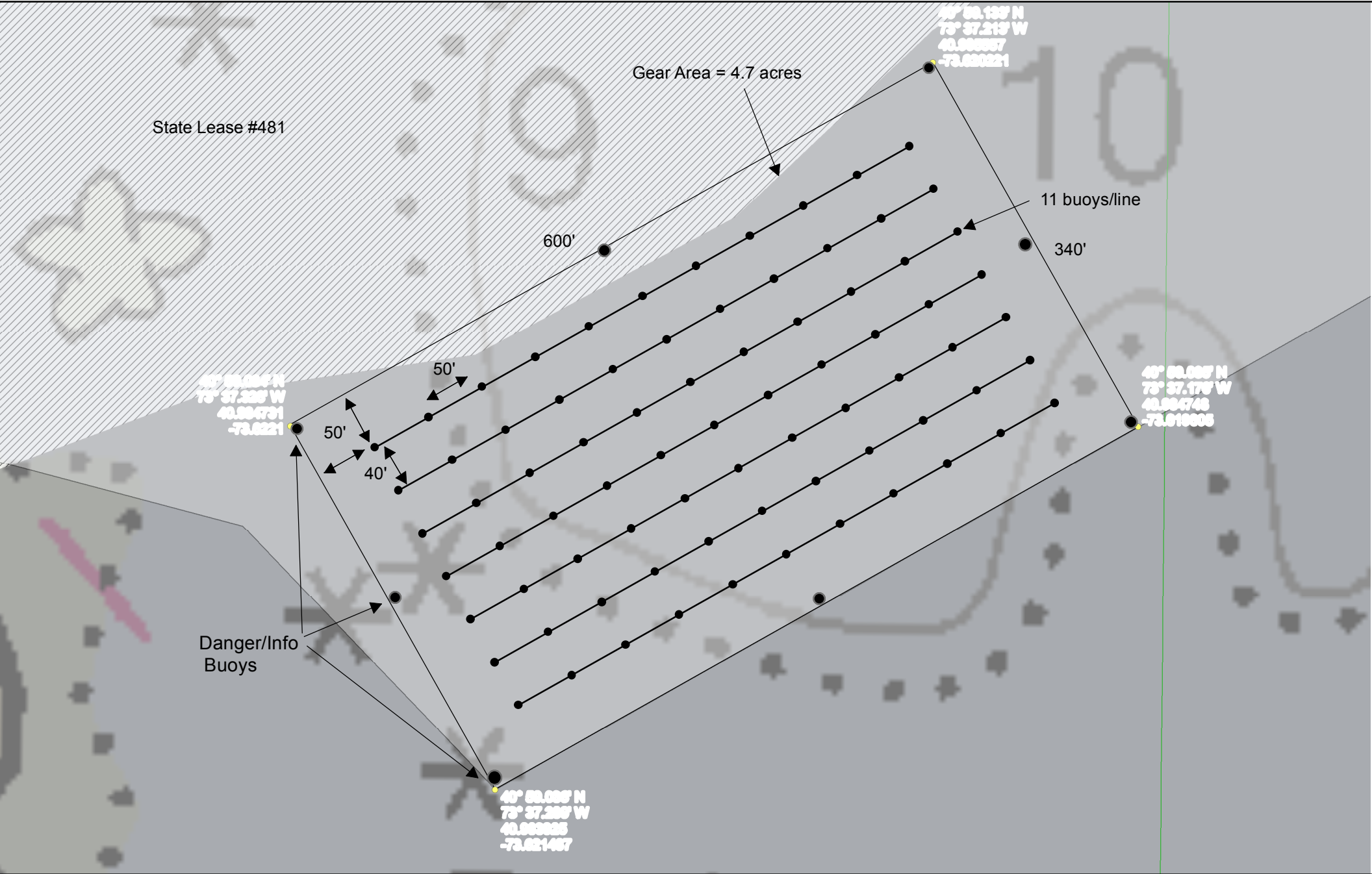

State Lease #481

Gear Area = 4.7 acres

11 buoys/line

600'

340'

40° 58.085' N
73° 37.289' W
40.994731
-73.6221

40° 58.085' N
73° 37.170' W
40.994748
-73.619905

40° 58.085' N
73° 37.289' W
40.993925
-73.621467

Danger/Info
Buoys

Atlantic Clam Farm
McCain Brown
L 481
2016-SW#10
Greenwich, CT
4.7 acres
Danger/Info Buoys
Fig.

Coordinate System: NAD 1983 StatePlane Connecticut FIPS 0600 Feet
Projection: Lambert Conformal Conic
Datum: North American 1983
False Easting: 1,000,000.0000
False Northing: 500,000.0000
Central Meridian: -72.7500
Standard Parallel 1: 41.2000
Standard Parallel 2: 41.8667
Latitude Of Origin: 40.8333
Units: Foot US

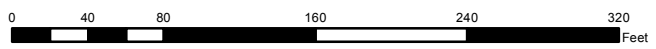

Legend		Sediment_type	
●	kelp_config	gravel	gravel
—	line_config	gravel-sand	gravel-sand
□	Aqua Gear Area	sand	sand
□	Managed_Shellfish_Beds_2014	sand-clay/silt	sand-clay/silt
		sand-silt/cayl	sand-silt/cayl
		sand/silt/clay	sand/silt/clay
		silt-clay/sand	silt-clay/sand

Map Date: 7/18/2017 REVISED 11/24/17

600 ft kelp line Layout

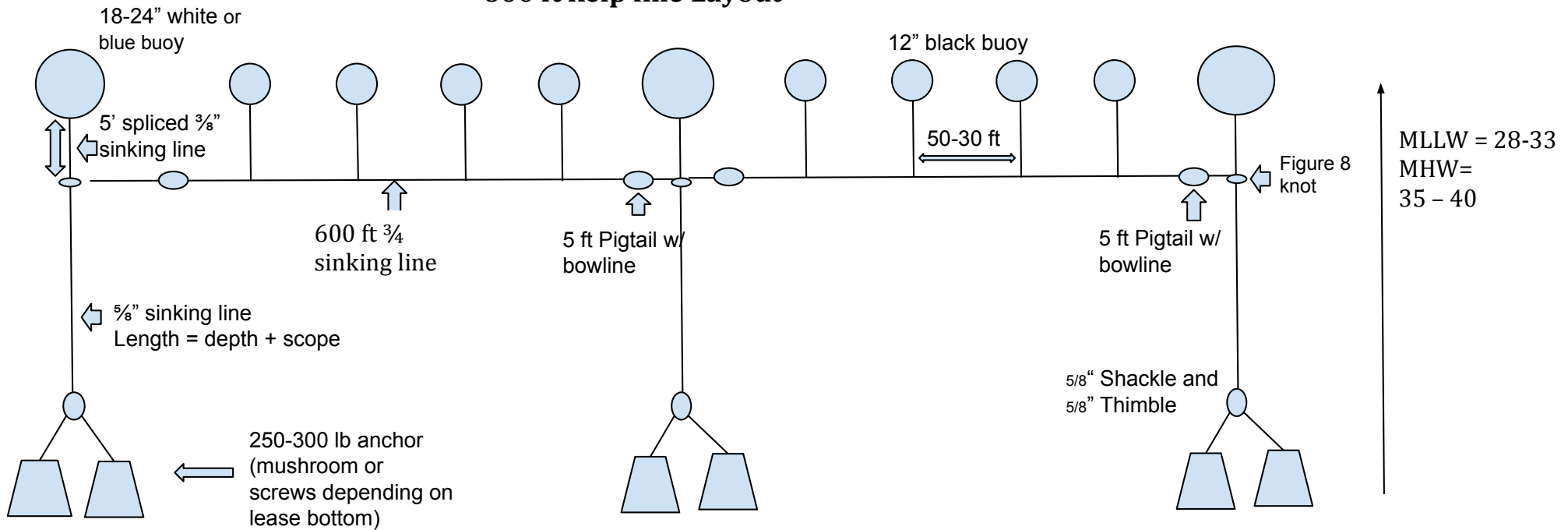

Bottom Type = gravel, gravel-sand,

Water current 0.7-0.8 knots

At full maturity, kelp blades will hang approx. 4 ft below the sink line, giving an approx. clearance of 19-26ft above the sound bottom