Monitoring Surveys at the New London
Disposal Site, August 1985 - July 1986

**Disposal Area
Monitoring System
DAMOS**

Contribution 60
November 1989



**US Army Corps
of Engineers**
New England Division

**MONITORING SURVEYS AT THE
NEW LONDON DISPOSAL SITE, AUGUST 1985 - JULY 1986**

CONTRIBUTION #60

November 1989

Report No.
SAIC-86/7540&C60

Submitted to:

Regulatory Branch
New England Division
U.S. Army Corps of Engineers
424 Trapelo Road
Waltham, MA 02254-9149

Submitted by:

J.H.Parker
E.C. Revelas
Science Applications International Corporation
Admiral's Gate
221 Third Street
Newport, RI 02840
(401) 847-4210



**US Army Corps
of Engineers**
New England Division

TABLE OF CONTENTS

		<u>Page</u>
1.0	INTRODUCTION	1
2.0	METHODS	2
2.1	Bathymetry and Navigation	2
2.2	Side Scan Sonar Survey	3
2.3	REMOTS® Sediment-Profile Photography	3
2.4	Sediment Sampling and Analysis	8
2.5	Benthic Community Analysis	9
2.6	Body Burden Analysis	10
2.7	In-situ Observations	13
3.0	RESULTS	13
3.1	Bathymetry	13
3.2	Side Scan Sonar Survey	17
3.3	REMOTS® Sediment-Profile Photography	18
3.4	Sediment Characteristics	27
3.5	Benthic Community Analysis.	28
3.6	Body Burden Analysis	30
3.7	In-situ Diver Observations	31
4.0	DISCUSSION	32
5.0	CONCLUSIONS	37
6.0	REFERENCES	39

TABLES
FIGURES

LIST OF TABLES

- Table 2-1. Comparison of REMOTS® Grain-Size Major Mode Estimates with Conventional Sediment Analyses, Rappahanock Disposal Sites - Chesapeake Bay.
- Table 2-2. Calculation of the REMOTS® Organism-Sediment Index (OSI) Value.
- Table 2-3. Instrument Operating Conditions and Detection Limits for Metals Analyzed by Flame Atomic Absorption Spectrophotometry.
- Table 2-4. Instrument Operating Conditions and Detection Limits for Metals Analyzed by Graphite Furnace Atomic Absorption Spectrophotometry.
- Table 2-5. Replicate Analysis of Pitar Samples and NRC Lobster Hepatopancreas Tissue to Determine Analytical Precision.
- Table 2-6. Summary of Diver Survey Operations at the New London Disposal Site, 11 July 1985.
- Table 3-1. Results of Physical Analysis of Sediment Samples Collected at an Area Southwest of the New London Disposal Site, August 1985.
- Table 3-2. Results of Chemical Analysis of Sediment Samples Collected at an Area Southwest of the New London Disposal Site, August 1985.
- Table 3-3. Results of Physical Analysis of Sediment Samples Collected at the New London Disposal Site, July 1986.
- Table 3-4. Chemical Analysis of Sediment Collected at the New London Disposal Site, July 1986.
- Table 3-5. Results of Statistical Comparisons Between 0-2 cm Core Sections for the Five Disposal Mounds at the New London Disposal Site and the Reference Station.
- Table 3-6. Results of Statistical Comparisons Between 2-10 cm Core Sections for the Five Disposal Mounds at the New London Disposal Site and the Reference Station.
- Table 3-7. Results of Statistical Comparisons Between 0-2 cm Core Sections and 2-10 cm Core Sections for the Five Disposal Mounds at the New London Disposal Site and the Reference Station.
- Table 3-8. Numerically Dominant Taxa in Order of Abundance at the New London Disposal Site, July 1985.

- Table 3-9. Taxa Highly Associated with the NL-85 or Reference Station.
- Table 3-10. Benthic Community Analysis of Sediment Samples Collected at the New London Disposal Site, July 1985.
- Table 3-11. Summary of Totals and Distribution of Individuals Among Major Phyla at the New London Disposal Site, July 1985.
- Table 3-12. Visual Descriptions of Biological Sediment Samples Collected at New London, July 1986.
- Table 3-13. Benthic Community Analysis of Sediment Samples Collected at the New London, July 1986.
- Table 3-14. Summary of Totals and Distribution of Individuals Among Major Phyla at the New London Disposal Site, July 1986.
- Table 3-15. Numerically Dominant Taxa in Order of Abundance at the New London Disposal Site, July 1986.
- Table 3-16. Trace Metals (Dry Weight) in Body Tissues of Pitar Collected at New London, July 1986.
- Table 3-17. Trace Metals (Wet Weight) in Body Tissues of Pitar Collected at New London, July 1986.
- Table 3-18. PCB's in Body Tissues of the Bivalve Pitar morrhuana Collected at the New London Disposal Site, July 1986.
- Table 3-19. Abundances of Megafauna Observed During Survey Dives at the New Lonadon Disposal Site, July 1986.
- Table 4-1. Comparison of Sediment Chemical Concentrations from New London Disposal Site with Other Reported Values in or near Long Island Sound.
- Table 4-2. Comparison of Body Tissue Chemical Concentrations in Pitar from New London Disposal Site with Other Reported Values in or near Long Island Sound.

LIST OF FIGURES

- Figure 2-1. Bathymetric survey grids conducted at the New London Disposal Site, 1985-1986.
- Figure 2-2. The REMOTS® sediment-profile camera, Benthos model 3731.
- Figure 2-3. REMOTS® station locations at the New London Disposal Site in 1985.
- Figure 2-4. REMOTS® stations occupied on the five disposal mounds ("NL-" designation) during the July 1986 survey at the New London Disposal Site.
- Figure 2-5. A REMOTS® data sheet.
- Figure 3-1. Contoured bathymetric chart of the New London Disposal Site, August 1985.
- Figure 3-2. Contoured bathymetric chart of an area immediately southwest of the New London Disposal Site, July 1985.
- Figure 3-3. Contoured bathymetric chart of the NLON-85 survey area, November 1985.
- Figure 3-4. Contoured bathymetric chart of the NLON-85 survey area, January 1986.
- Figure 3-5. Contoured chart of depth differences between pre- and post- disposal at the NLON-85 survey area.
- Figure 3-6. Contoured bathymetric chart of the New London Disposal Site, July 1986.
- Figure 3-7. Contoured bathymetric chart of the NLON-86 survey area, July 1986.
- Figure 3-8. Contoured bathymetric chart of the NLON-85 survey area, July 1986.
- Figure 3-9. Results of the side scan survey at the New London Disposal Site, August 1985.
- Figure 3-10. Photograph of side scan record at the NL-RELIC mound in the New London Disposal Site.
- Figure 3-11. The distribution of grain-size major mode at the New London Disposal Site, July 1985.
- Figure 3-12. A REMOTS® photograph from New London station Q-7.

- Figure 3-13. Frequency distributions of boundary roughness, RPD, and OSI values for the New London Disposal Site, July 1985.
- Figure 3-14. The distribution of mean apparent RPD depths at the New London Disposal Site, July 1985.
- Figure 3-15. The distribution of infaunal successional stages at the New London Disposal Site, July 1985.
- Figure 3-16. A REMOTS® photograph from New London station O-3 showing a retrograde Stage II assemblage.
- Figure 3-17. A REMOTS® photograph from New London station Q-3 showing a healthy (Stage II) amphipod tube mat.
- Figure 3-18. A REMOTS® photograph from New London station O-1 showing a Stage II--> III assemblage (Stage II going to Stage III).
- Figure 3-19. The distribution of OSI values at the New London Disposal Site, July 1985.
- Figure 3-20. The distribution of grain-size major mode at the Southwest survey area, August 1985.
- Figure 3-21. Frequency distributions of boundary roughness, RPD, and OSI values for the Southwest survey area, August 1985.
- Figure 3-22. The distribution of mean apparent RPD depths at the Southwest survey area, August 1985.
- Figure 3-23. The distribution of infaunal successional stages at the Southwest survey area, August 1985.
- Figure 3-24. The distribution of OSI values at the Southwest survey area, August 1985.
- Figure 3-25. The distribution of grain-size major mode at the NLON-85 survey area, November 1985.
- Figure 3-26. The distribution of mean apparent RPD depths at the NLON-85 survey area, November 1985.
- Figure 3-27. Frequency distributions of boundary roughness, RPD, and OSI values for the NLON-85 survey area, November 1985.
- Figure 3-28. The distribution of infaunal successional seres at the NLON-85 survey area, November 1985.

- Figure 3-29. A REMOTS® photograph from NLON-85 station 4-C. High sediment oxygen demand and/or low oxygen supply water conditions were indicated by the lack of an apparent RPD.
- Figure 3-30. The distribution of OSI values at the NLON-85 survey area, November 1985.
- Figure 3-31. The distribution and thickness of dredged material at the NLON-85 survey area, January 1986.
- Figure 3-32. A REMOTS® photograph from NLON-85 station 500S showing a relatively thin dredged material layer (3.4 cm).
- Figure 3-33. Frequency distributions for boundary roughness, RPD, and OSI values for the NLON-85 survey area, January 1986.
- Figure 3-34. The distribution of mean apparent RPD depths at the NLON-85 survey area, January 1986.
- Figure 3-35. A REMOTS® photograph from NLON-85 station 400E showing a dredged material layer (low reflectance) and an extremely shallow RPD (arrow).
- Figure 3-36. The distribution of infaunal successional seres at the NLON-85 survey area, January 1986.
- Figure 3-37. The distribution of OSI values at the NLON-85 survey area, January 1986.
- Figure 3-38. The distribution of dredged material at the New London Disposal Site in July 1986.
- Figure 3-39. A REMOTS® photograph from NLON-85 station 300W showing a distinct dredged material layer approximately 8 cm thick.
- Figure 3-40. The distribution of grain-size major mode at the New London Disposal Site, July 1986.
- Figure 3-41. The distribution of grain-size major mode at the Southwest grid, July 1986.
- Figure 3-42. A REMOTS® photograph from the southwest reconnaissance grid showing a bottom consisting of coarse sand and shell fragments.
- Figure 3-43. Frequency distributions of boundary roughness values for all stations in the New London Disposal Site (A), for the NL-85 mound (B), for the Reference station (C), and for the Southwest grid (D), July 1986.

- Figure 3-44. The distribution of mean apparent RPD depths at the New London Disposal Site, July 1986.
- Figure 3-45. The distribution of mean apparent RPD depths at the Southwest grid, July 1986.
- Figure 3-46. Frequency distributions of mean apparent RPD depths for all stations in the New London Disposal Site (A), for the NL-85 mound (B), for the Reference station (C), and for the Southwest grid (D), July 1986.
- Figure 3-47. The distribution of successional stages at the New London Disposal Site, July 1986.
- Figure 3-48. A REMOTS® photograph from NLON-85 station 400E showing a well-developed Stage II assemblage characterized by tube-dwelling amphipods.
- Figure 3-49. A REMOTS® photograph from the New London Reference Station showing a disturbed surface amphipod tube mat.
- Figure 3-50. The distribution of successional stages at the Southwest grid, July 1986.
- Figure 3-51. The distribution of OSI values at the New London Disposal Site, July 1986.
- Figure 3-52. The distribution of OSI values at the Southwest grid, July 1986.
- Figure 3-53. Frequency distributions of OSI values for all stations in the New London Disposal Site (A), for the NL-85 mound (B), for the Reference station (C), and for the Southwest grid (D), July 1986.
- Figure 3-54. A lobster out of its burrow at the disposal mound.
- Figure 3-55. A lobster burrowed under debris.
- Figure 3-56. A typical burrow excavated into the mud of a slight topographic rise.
- Figure 3-57. Shell hash and amphipod tube mat surface conditions in the northeast section of the New London Disposal Site.
- Figure 3-58. A crustacean foraging excavation.
- Figure 3-59. Typical surface conditions containing amphipod tubes, sparse shell hash, and an occasional hydroid.

- Figure 3-60. Winter flounder swimming over amphipod tube mat.
- Figure 3-61. Starfish preying on infauna.
- Figure 3-62. Spider crab foraging by winnowing amphipod tubes and sediment material through mandibles.
- Figure 3-63. Mucous trail left by channeled whelk moving over sediment surface.

1.0 INTRODUCTION

The New London Disposal Site, located approximately two nautical miles south of the mouth of the Thames River, consists of a one nautical mile square centered at 41°16.1'N and 72°04.6'W. This disposal site has been monitored by the DAMOS program since 1977. Initially, the monitoring was in response to concerns about possible environmental impacts resulting from the disposal of dredged material removed from the Thames River to accommodate deep draft submarines. Since that time, dredging has continued both in the Thames River and at other locations in the eastern Long Island Sound region, resulting in approximately 150,000 m³ (200,000 yd³) of dredged material being deposited annually at the New London Disposal Site.

During the periods 30 July to 29 August and 7 to 14 November 1985 and 23 to 24 January, 1 to 14 July, and 23 September 1986, field operations were conducted at the New London Disposal Site to provide information about the fates and effects of past dredged material disposal operations. The field operations included precision bathymetric surveys, side scan sonar surveys, sediment-profile photography (REMOTS®), and sediment sampling for chemical, benthic community, and contaminant body burden analyses. The primary objectives of the work performed during the 1985 and 1986 studies were:

- to determine if management controls initiated by the New England Division, US Army Corps of Engineers had minimized dispersion of dredged material and subsequent environmental impacts both within and outside the site boundaries,
- to define and survey a point within the site to determine its suitability for disposal of dredged material in the fall of 1985,
- to determine the concentrations of selected chemical constituents in sediments at both the disposal and reference sites,
- to analyze the benthic community structure at the disposal site and reference station for comparison with future monitoring studies,
- to perform in-situ observations of physical and biological conditions at the sediment surface within the disposal site and provide photo documentation of these conditions, and
- to collect baseline data on body burden levels of selected contaminants in local benthic fauna both within the disposal site and at nearby reference stations for

comparison with future monitoring studies and to determine if a relationship exists between sediment contaminant concentrations and organism body burdens.

2.0 METHODS

2.1 Bathymetry and Navigation

The precise navigation required for all field operations was provided by the SAIC Integrated Navigation and Data Acquisition System (INDAS). This system uses a Hewlett-Packard 9920 Series computer to collect position, depth, and time data for subsequent analysis as well as to provide real-time navigation. A display with the survey lanes and the real-time position of the vessel is provided to the helmsman. The positional information is recorded on magnetic disk every second along with depth and time. The computer system calculates accurate positions from the range data provided by the positioning system and is capable of converting from state plane coordinates in the Transverse Mercator system to Lambert or Mercator coordinates.

Positions were determined to an accuracy of ± 3 meters from ranges provided by a Del Norte Trisponder System. Shore stations were established over known benchmarks used in previous surveys to allow accurate comparisons between the surveys. For the present surveys, shore stations were established in Connecticut at Millstone Point and New London Light.

On 5 and 6 August 1985, a precision bathymetric survey was performed at the New London disposal site. The survey (designated NLON Master) consisted of 58 lanes, 3950 meters long, and spaced 50 meters apart. This resulted in a survey area covering the entire disposal site and extending 500 meters beyond its borders (Figure 2-1). Depth measurements collected during this survey were made using an Edo Western model 548E survey fathometer interfaced to an Edo model 261C Digitrak depth digitizer. The system was operated at a frequency of 24 KHz with accuracies to ± 20 cm in the depths encountered at this site.

On 29 July 1985, a bathymetric survey was conducted at a location just outside the southwest boundary of the New London Disposal Site. This location had been identified as a stressed environment from analysis of REMOTS photos obtained earlier in July and mistakenly was considered a candidate area for disposal of dredged material. However, the fact that this area was outside the disposal site boundary disqualified it from further consideration as a disposal location. The bathymetric survey performed in this area consisted of 33 lanes 800 meters long spaced 25 meters apart, covering an area 800 meters square (Figure 2-1); it was conducted with a Raytheon DE-719B Precision Survey Fathometer and a model SSD-100 depth digitizer. This system

operated at a frequency of 208 kHz and measured depth to a resolution of 3.0 cm (1.0 feet), with an accuracy ± 10 cm at these depths. On 14 November 1985, another bathymetric survey was conducted at a location in the eastern portion of the disposal site (designated NLON-85) for evaluation as a new disposal point. This survey covered an area 900 meters square and consisted of 37 lanes 900 meters long spaced 25 meters apart (Fig. 2-1). On 23 January 1986, a post-disposal bathymetric survey was conducted around the NLON-85 disposal point. This survey was performed over the identical grid as the November baseline survey so that direct comparison of the data would reveal the extent of dredged material and provide an estimate of the volume of material disposed. The November and January surveys were conducted using the Raytheon fathometer.

In July 1986, a bathymetric survey was again conducted over the identical survey lanes of the NLON Master survey of 1985. Additional bathymetric surveys (designated NLON-85 and NLON-86 in Figure 2-1) were conducted to provide 25 meter lane spacing over the four disposal mounds (NL-I, NL-II, NL-III, NL-RELIC) which existed at the disposal site as a result of past disposal operations and the area where disposal activities were presently occurring (NLON-85). This closer lane spacing provides the required resolution for subsequent data analysis and the production of detailed depth contour charts.

Analysis of the bathymetric data standardizes the raw depth values to Mean Low Water by correcting for the depth of the transducer and for tidal changes during the survey.

2.2 Side Scan Sonar Survey

On 28 August 1985, a side scan sonar survey was performed at the New London Disposal Site. This survey consisted of 20 lanes 3100 meters long and spaced 150 meters apart. This resulted in a survey area of 3100 by 2850 meters which extended outside of the disposal site boundaries in excess of 500 meters in each direction. The Klein Side Scan, which was operated at a frequency of 100kHz, was set for a range of 100 meters on either side of the towed fish. This provided a 50 meter overlap of lane information to insure that important features were not missed.

2.3 REMOTS® Sediment-Profile Photography

REMOTS® surveys of the New London Disposal Site were first performed in June 1984. REMOTS® is used to detect and map the distribution of thin (1-20cm) dredged material layers. This capability complements the precision bathymetric data which can reliably measure bottom elevation changes greater than 15 cm. In addition, REMOTS® is used to map benthic disturbance gradients and

to monitor the process of infaunal recolonization on and adjacent to disposal mounds.

REMOTS® photographs were taken with a Benthos Model 3731 Sediment-Profile Camera (Benthos, Inc. North Falmouth, MA). The REMOTS® camera is designed to obtain in-situ profile photographs of the top 15-20 cm of sediment (Figure 2-2). Functioning like an inverted periscope, the camera consists of a wedge-shaped prism with a front face plate and a back mirror mounted at a 45 degree angle to reflect the cross-sectional photograph of the sediment-water interface up to the camera. The camera is mounted horizontally on top of the prism. The prism assembly is moved up and down by producing tension or slack on the winch wire. Tension on the wire keeps the prism in the up position. When the camera frame is lowered to the seafloor, slack on the wire allows the prism to vertically penetrate the seafloor. A piston ensures that the prism enters the bottom slowly and does not disturb the sediment-water interface. On impact with the bottom, a trigger activates a 13-second time delay on the shutter release; once the prism comes to rest in the sediment, a photo is taken. Because the sediment photographed is directly against the face plate, turbidity of the ambient seawater does not affect photograph quality. When the camera is raised, a wiper blade cleans off the faceplate; the film is advanced by a motor drive, the strobe is recharged, and the camera can be lowered for another photograph.

The first of three REMOTS® surveys performed in 1985 occurred in July (Figure 2-3). A total of 176 REMOTS® stations were sampled within the disposal site and a 500 meter peripheral boundary. Stations on the margins of the site were spaced at 200 meter intervals, while stations within the site were 400 meters apart. A single REMOTS® photo was obtained at each station. The purposes of this REMOTS® survey were to describe the habitat quality and determine the distribution of dredged material along the margins of the disposal site, evaluate habitat variability and recolonization in the disposal site, and map habitat distributions. In addition, the July REMOTS® data were used to assist in the selection of a disposal point for future New London dredged material. Based on the results of the July cruise, an area in which a new disposal point might be selected was surveyed in August. This sampling grid consisted of a 5 X 5 matrix with stations spaced every 200 meters (Figure 2-3). Three replicate REMOTS® photographs were obtained at each station. The area was found to be a high kinetic environment which was not suitable as a containment area. More importantly, the area inadvertently had been located outside the southwestern boundary of the New London Disposal Site and, therefore, was not considered further as a viable disposal point. In November 1985, another candidate disposal point (designated NL-85) was surveyed in the central eastern portion of the disposal site. This REMOTS® grid consisted of a 4 X 4 matrix with stations spaced at 300 meter intervals (Figure 2-3). Three replicate photographs were taken at each

station, with the exception of stations 4-D and 2-A where only two photographs were obtained.

In January 1986, three replicate photographs were taken at stations in a cross-shaped grid centered on the NL-85 disposal mound (Figure 2-4) to characterize the baseline conditions of the area for comparison with post-disposal data. In July 1986, sampling was repeated at the NL-85 mound as well as at cross-shaped grids centered on each of the other four disposal mounds at the New London Site (NL-RELIC, NL-I, NL-II, and NL-III, Figure 2-4). The July 1986 monitoring program emphasized the NL-85 mound in order to document the impacts of the most recent disposal operations. Three replicate REMOTS® photographs (one for analysis, and two to be archived for possible future analysis) were scheduled to be taken at each station within the New London Disposal Site. Due to an electronic malfunction of the camera on the last day of deployment, photographs were not obtained from 23 stations. Nineteen of these missed stations were located in the northern portion of the NL-RELIC and NL-II disposal mounds (Figure 2-4). This region of the disposal site, located 500 to 1200 meters from the current disposal point, was not considered critical to the monitoring goals of the 1986 survey. A single REMOTS® photograph also was obtained at each of 24 stations in a 6 X 4 reconnaissance grid (100 m spacing) located beyond the southwest corner of the disposal site (Figure 2-4). This area was located beyond the station grid sampled in August 1985 (see Figure 2-3). Previous REMOTS® surveys at the New London Disposal Site had suggested the potential spread of dredged material toward this region. In addition, twenty REMOTS® replicate photographs were also obtained at the New London Reference station, located about 2000 meters east of the disposal site (41°15.60N, 72°3.64W) for comparison to on-site conditions.

REMOTS® measurements of all physical parameters and some biological parameters were measured directly from black and white film negatives using a video digitizer and computer image analysis system. Negatives are used for analysis instead of positive prints in order to avoid changes in image density that can accompany the printing of a positive image. The image analysis system can discriminate up to 256 different gray scales, so subtle features can accurately be measured. Proprietary SAIC software allows the measurement and storage of data on 22 different variables for each REMOTS® photograph obtained (Figure 2-5). Automatic disk storage of all parameters measured allows data of interest to be compiled, sorted, compared statistically, or displayed graphically.

Specific measurement techniques for the REMOTS® parameters indicated in Figure 2-5 are presented in the following sections:

Sediment Type Determination

The sediment grain-size major mode and range are visually estimated from the photographs by overlaying a grain-size comparator composed of seven Udden-Wentworth size classes: ≥ 4 phi (silt or finer), 4-3 phi (very fine sand), 3-2 phi (fine sand), 2-1 phi (medium sand), 1-0 phi (coarse sand), 0-(-)1 phi (very coarse sand), <-1 phi (granules or larger). The accuracy of this method has been documented by comparing REMOTS® estimates with grain-size statistics determined from laboratory sieve analyses (Table 2-1). In most cases where the REMOTS® grain-size estimate is different from the granulometric analysis, the major and minor grain-size modes have been found in adjacent size classes. The REMOTS® visual estimates in some cases can not resolve the major mode when adjacent class peaks are comparable.

Prism Penetration Depth

The REMOTS® prism penetration depth is determined by measuring both the largest and smallest linear distance between the sediment-water interface and the bottom of the film frame. Prism penetration is potentially a noteworthy parameter; if the amount of weight used in the camera is held constant throughout a survey, the camera functions as a static-load penetrometer. Comparative penetration values from sites of similar grain-size can give an indication of the relative sediment water content.

Surface Boundary Roughness

Surface boundary roughness is determined by measuring the vertical distance (parallel to the film border) between the highest and lowest points of the sediment-water interface. In addition, the origin of this small-scale topographic relief is indicated when it is evident (physical or biogenic).

Mud Clasts

When fine-grained, cohesive sediments are disturbed either by physical bottom scour or faunal activity (e.g., decapod foraging), intact clumps of sediment are often scattered about the seafloor and detected in REMOTS® photographs. These mud clasts are counted, the diameter of a typical clast measured, and their oxidation state assessed. The abundance, distribution, oxidation state, and shape of mud clasts are used to make inferences about the recent pattern of seafloor disturbance in an area. Mud clasts which occur as sampling artifacts (i.e., as a result of physical bottom disturbance by the camera prism) usually have an anomolous shape or appearance which allows them to be distinguished from those which occur naturally.

Apparent Redox Potential Discontinuity (RPD) Depth

When there is oxygen in the overlying water column in coastal areas, near-surface sediment will have a higher reflectance value relative to hypoxic or anoxic sediment underlying it. This is because the oxidized surface sediment contains particles coated with ferric hydroxide (an olive color when associated with particles), while the sulphidic sediments below this oxygenated layer are grey to black. The boundary between these two sediment types is called the apparent redox potential discontinuity (RPD). The term "apparent" is used because the true RPD ($E_h = 0$, as measured with microelectrodes) is usually located at a shallower depth in the sediment than the bottom of the high reflectance layer. This phenomenon is related to organisms mixing grains with ferric hydroxide coatings downward below the true RPD ($E_h = 0$). Once transported below the true RPD, the oxidized coatings may be metastable for several weeks to months in an otherwise anoxic ($E_h < 0$) environment. This oxidized, high-reflectance area is digitized, measured to scale, and divided by the prism window width to obtain a mean depth for the apparent RPD. The RPD depth is a sensitive indicator of the biological mixing depth, infaunal successional status, and within-station patchiness. In the absence of bioturbating infauna, the RPD will achieve a maximum depth of 2 mm in fine-grained sediments solely by diffusion (Rhoads, 1974).

Sedimentary Methane

At extreme levels of organic-loading, pore-water sulfate is depleted and methane bubbles are produced in the sediment column. These gas-filled voids are readily discernable because of their irregular, generally circular aspect and glassy texture (due to the reflection of the strobe off the gas). If present, the number and total areal coverage of all methane pockets is measured.

Infaunal Successional Stage

The mapping of infaunal successional stages is based on the theory that primary succession results in "the predictable appearance of macrobenthic invertebrates belonging to specific functional types following a benthic disturbance. Because functional types are the biological units of interest..., our definition does not demand a sequential appearance of particular invertebrate species or genera" (Rhoads and Boyer, 1982). The term disturbance can refer to a natural process such as seafloor erosion, changes in seafloor chemistry, macrofaunal foraging disturbances which cause major reorganization of the resident benthos, or anthropogenic impacts such as dredged material or sewage sludge dumping, trawling, thermal effluents from power plants, industrial discharge, etc.

Pioneering benthic assemblages (Stage I) usually consist of dense aggregations of near-surface, tube-dwelling polychaetes.

This functional type is usually associated with a shallow depth of bioturbation which results in a shallow redox boundary. In the absence of further disturbance, these early successional assemblages are eventually replaced by infaunal deposit feeders (Stage II). Typical Stage II species are shallow dwelling bivalves or tubicolous amphipods. Stage III taxa represent high-order successional stages typically found in low disturbance regimes. Many of these invertebrates feed at greater depth in a head-down orientation. The localized feeding activity results in distinctive excavations called feeding voids. These deep-dwelling infaunal taxa preferentially ingest the finer sediment particles and reject coarse-grained material. The bioturbational activities of these deposit feeders are responsible for aerating the sediment and causing the redox horizon to be located several centimeters below the sediment-water interface. In the retrograde transition of Stage III to Stage I, it is sometimes possible to recognize the presence of relict (i.e., collapsed and inactive) feeding voids.

These end-member stages (Stages I and III) are easily recognized in REMOTS® photographs by the presence of dense assemblages of near-surface polychaetes and/or the presence of subsurface feeding voids; both types of assemblages may be present in the same photograph (classified as a Stage I on Stage III).

REMOTS® Organism-Sediment Index

A multi-parameter REMOTS® Organism-Sediment Index (OSI) has been constructed to characterize habitat quality. Habitat quality is defined relative to two end-member standards. The lowest value is given to those bottom substrates which have low or no dissolved oxygen in the overlying bottom water, no apparent macrofaunal life, and methane gas present in the sediment. The OSI value for such a condition is minus 10. An aerobic bottom with a deeply depressed RPD, evidence of a mature macrofaunal assemblage, and no apparent methane gas bubbles at depth will have an OSI value of plus 11. The OSI is arrived at by summing a subset of indices (Table 2-2). The OSI is an excellent parameter for mapping disturbance gradients in an area and documenting ecosystem recovery after disturbance (see Germano and Rhoads, 1984).

2.4 Sediment Sampling and Analysis

During the August 1985 survey, triplicate sediment samples were collected at five stations at the southwest corner of the survey area (see Figure 3-2) using a 0.1 m² Smith-McIntyre Grab Sampler. Four polycarbonate plastic core liners (6.5 cm ID) were pushed into the sediment grab sample and extracted; three cores were combined and placed into a bag for subsequent chemical analysis by the NED laboratory. The fourth core was bagged for physical analysis. All samples were kept cold and returned to the NED laboratory where they were stored at 4°C until analyzed.

During the July 1986 survey, triplicate sediment samples were collected at the center of each of the five disposal mounds (Figure 2-4) and at the Reference station using collection and handling methods described above. However, the top 2 cm of six cores were bagged separately to determine whether the surface sediment was relatively more or less contaminated than the deeper sediment due to the desorption of contaminants or the deposition of cleaner material. Parameters measured included grain size, trace metals, and several organic constituents.

Sediment analyses were conducted using methods described by the U.S. Environmental Protection Agency (Plumb, 1981). Mercury analysis was performed using acid digestion and cold vapor atomic absorption spectrophotometry; arsenic analysis was accomplished using acid digestion and gaseous anhydride atomic absorption spectrophotometry. The other trace metals (Pb, Zn, Cr, Cu, Cd, and Ni) were analyzed using acid digestion and flame atomic absorption spectrophotometry.

Carbon, hydrogen, and nitrogen analyses were conducted with an autoanalyzer using a combustion technique. Oil and grease measurements were made by extracting the sediment with freon and then analyzing the freon by infrared spectrophotometry. PCBs were extracted with hexane and also analyzed by electron capture gas chromatography.

2.5 Benthic Community Analysis

Quantitative benthic samples were obtained at the newly selected NL-85 disposal point prior to disposal in July 1985 and after disposal in July 1986. Benthic samples were also collected at the Reference station on both occasions.

Five sediment samples were collected for benthic community analysis at each station and sieved onboard the research vessel through nested 2 mm and 0.5 mm mesh screens. The material retained in the sieves from each grab sample was preserved with buffered formalin for later sorting and identification in the laboratory. Two of the five samples were archived for future reference. A small subsample of each sediment grab was collected with a 3 cm inner diameter core tube for grain size analysis by the NED laboratory. A visual description of each sediment grab was recorded prior to sieving. In the laboratory, samples were stained with 0.2% rose bengal and sieved on 1.0 and 0.5 mm screens immersed in water. Many amphipod tubes and most organisms were separated from sand and gravel by repeated suspension and decantation. The coarse washed gravel was sorted in glass trays with a white background. All other fractions were examined with a binocular microscope.

Organisms were identified to species in most cases. Individuals from all fractions were combined during counting. All individuals were stored in 70% alcohol. A reference collection was made of all specimens found in the 1985 and 1986 samples and is maintained at the University of Rhode Island Graduate School of Oceanography under the direction of Mr. Sheldon Pratt. Sieve residues were described in laboratory notes and discarded.

2.6 Body Burden Analysis

Test organisms for body burden analysis were collected during the 1986 survey at the Reference station and at the NL-II disposal mound using the Smith-McIntyre grab. Sediment was sieved through a 2mm mesh and the suspension-feeding organisms (the bivalve Pitar) were isolated and placed in seawater. Enough biomass (approximately 25 grams, wet weight) was collected for triplicate analyses. Sufficient biomass of the original target species, the amphipod Ampelisca sp., was not present at the time of sampling. The bivalves were maintained for 24 hours at ambient temperature to allow any gut contents to be expelled before they were frozen for transport to the laboratory for analysis. They were analyzed for eight trace metals and PCBs at the SAIC laboratory in La Jolla, California.

In the laboratory, all specimens were thawed before dissection. The bivalve tissue was removed from the shell using teflon forceps, rinsed with deionized water, and placed on acid-cleaned watch glasses. The samples were blotted with a Shur-wipe to remove excess water and homogenized in their original container using teflon forceps and knives. For Hg analysis, approximately 25% of each sample was transferred to a labeled 30 ml polyethylene bottle and frozen to await additional preparation. Another 25% of each sample was transferred to a labeled, preweighed 60 ml polypropylene jar for trace metal analyses. The wet weights of these samples were recorded. The remaining 50% of each sample was transferred to a kilned glass jar and frozen for PCB analysis.

The samples for trace metal analyses were frozen and then taken to a constant weight using a Virtis Unitrap II freeze dryer. Subsequently, the sample dry weights were recorded and dry/wet weight ratios were calculated. These ratios were later used to convert the wet weights of the Hg samples to dry weights because wet samples were used for Hg analysis. Following the drying process, the samples were ground to a powder (in their original containers) using a Spex mixer-mill.

Approximately 1 g aliquots of powdered tissue were weighed into quartz boats. They were ashed overnight in a Branson/International Plasma Corporation #1005-488 ANQ low-temperature asher using CF_4/O_2 plasma. The ashed samples were then

quantitatively transferred to 200 ml, tall-form Pyrex beakers using redistilled HNO_3 . The total volume of HNO_3 was then adjusted to 10 ml and the beakers covered with watch glasses. The samples were heated on a hot plate to near dryness and then removed and allowed to cool. Next, 2 ml of 30% H_2O_2 (ULTREX) were added. The samples were again placed on a hot plate and heated until the oxidative frothing ceased. The samples were cooled and brought to volume in 50 ml polypropylene flasks with deionized Milli-Q water. The samples were then transferred to labeled 60 ml polyethylene bottles until subsequent analysis.

After the initial treatment, a modification of EPA standard methods was used for sample preparation for the analysis of Hg. Approximately 1 g wet weight of tissues was weighed into labeled 50 ml borosilicate bottles with polypropylene screw caps. Next, 5 ml of redistilled HNO_3 were added. The samples were then loosely capped and allowed to stand overnight at room temperature in the polyethylene hood. To each sample, 5 ml of Hg-free H_2SO_4 were added, and the samples were heated in a 95°C water bath for two hours. Next, they were allowed to cool followed by refrigeration until time for analysis. NRC Lobster Hepatopancreas Tissue (Tort-1) and sample reagent blanks were prepared in the same manner as the samples.

Samples were analyzed by atomic absorption spectrophotometry (AAS) using both flame (Table 2-3) and graphite (Table 2-4) furnaces according to conditions described in Perkin-Elmer Instrument manuals. The instrument used was a Perkin-Elmer 603 equipped with Air/ C_2H_2 and $\text{N}_2\text{O}/\text{C}_2\text{H}_2$ burners, an HGA-2200 graphite furnace, an AS-1 Autosampler, a deuterium (D_2) lamp background corrector, and a Perkin-Elmer 056 Recorder. The D_2 background corrector was used for all analyses. Standard additions were routinely performed along with standard calibrations. When the two calibration curves deviated significantly, calculation of sample concentrations were based upon the standard addition calibration. When agreement was good, a combination of the standard addition/standard calibration was used. Sample blanks and NRC standards were analyzed in the same manner as the samples. AAS working standards were prepared from a mixed 10 ppm stock in 1% HNO_3 using Fisher 1000 ppm standards.

Measurements of the concentrations of Hg were conducted by cold vapor atomic absorption spectrophotometry using a Laboratory Data Control #1235 Mercury Monitor equipped with a Perkin-Elmer 023 recorder. Samples were reduced to destroy the excess KMnO_4 using a 10% solution of $\text{NH}_2\text{OH}\cdot\text{HCl}$ in 10% NaCl . Next, the samples were reduced to the Hg^0 state using a 20% solution of SnCl_2 in 3N HCl . The resulting Hg vapor was purged with N_2 through the above described system. Sample blanks and NRC Lobster Hepatopancreas Tissue were analyzed in the same manner as the samples. Working standards were prepared from a 10 ppm stock in

1% HNO₃ using Fisher 1000 ppm standards. Standard additions were routinely performed.

The quality of the tissue trace metal data was assured in several ways. These included the analysis of blank samples and the measurements of the precision and accuracy of the results.

Blank concentrations were all well below the element concentrations for these samples. Measurements of the precision of the trace metals analyses were made by doing replicate analysis of a sample of Pitar morrhua and NRC Lobster Hepatopancreas Tissue (Table 2-5). The relative standard deviations of replicate analyses of the Pitar morrhua were less than 20% for all elements.

Results from the analyses of certified NRC Lobster Hepatopancreas Tissue also showed excellent accuracy for the trace metal analysis methods. The concentrations reported for all eight metal elements in the NRC tissue were very similar (91-108% agreement) to the NRC values indicating good accuracy (Table 2-5).

Samples for organic analysis were first sonicated with methanol and then three additional times with hexane. The methanol/hexane mixture was partitioned via separatory funnel techniques. The aqueous methanol was extracted with additional hexane, and the combined hexane extracts were decanted through Na₂SO₄ and concentrated to 1.0 ml using standard Kuderna-Danish (K-D) equipment and techniques. Next, 0.5 ml aliquots of the concentrated samples were adjusted to 1.0 ml with acetone and eluted with hexane over neutral alumina columns.

Samples were analyzed for their PCB content according to EPA Federal Register Method 608, using a Hewlett Packard 5840A gas chromatograph equipped with an electron capture detector and a 30 m DB 5 fused silica capillary column. The column oven temperature was programmed from an initial temperature of 45°C to 290°C using a three-step program. The program rate was 7°C/min to 164°C, then 2°C/min to 214°C, and finally 10°C/min to 290°C. Quantification was by the external standard calibration method.

Tissue samples were screened for the presence of several different PCB formulations. These included Aroclors 1016, 1221, 1232, 1242, 1248, 1254, and 1260. The detection limits presented are for Aroclor 1254, commonly found in the marine environment. Because each formulation contains different amounts of chlorine, the response factors can vary between mixtures. The detection limits for Aroclors 1016, 1242, and 1260 were the same as that achieved for 1254. The detection limits were higher for the other mixtures by factors of 4.0, 2.0 and 1.6 for Aroclors 1221, 1232, and 1248, respectively. In order to report a total PCB concentration one must add the concentration of all the different mixtures.

The PCB analyses were quality assured by measuring the recovery of a surrogate compound (dibutylchloroendate) in each sample. The recovery of this compound was 70% ±15 for the New London samples.

2.7 In-situ Observations

A team of diver/scientists conducted underwater observations at the New London Disposal Site to observe sediment surface conditions, identify species present and their relative abundances, observe faunal-substrate interactions, and provide photo documentation of conditions. Diver-operated epibenthic net samples (0.50m wide by 0.20m net height; 1mm mesh; 15m tow) were taken at discrete points for enumeration of abundant smaller species associated with the sediment surface. Photo documentation was accomplished with diver-held 35mm camera and electronic flash equipment.

Diver survey operations were conducted at the New London Disposal Site on 11 July 1985. A total of four dives were made at this time. These dives took place in an area in the southwest quadrant of the disposal site where mussel beds were prevalent, as well as in the northeast and northwest quadrants and over the NL-I disposal mound (Table 2-6).

3.0 RESULTS

3.1 Bathymetry

The results of the August 1985 NLON Master bathymetric survey (Figure 3-1) depicts the bottom topographic features present at the New London Disposal Site. In general, the ambient bottom appeared to slope from a depth of approximately 16 meters in the northern portion of the area to a depth of 24 meters to the south. The area was relatively flat in an east/west direction except in the extreme southwest corner. The steep slope immediately southwest of the disposal site descended from an average depth of about 25 meters to a depth in excess of 59 meters over a horizontal distance of approximately 800 meters. The historic NL-I, NL-II, NL-III, and NL-RELIC mounds resulting from disposal operations during the late 1970's and early 1980's are clearly visible.

A location just beyond the southwest boundary of the disposal site was evaluated for the deposition of dredged material from an anticipated project in the Thames River. This location was chosen primarily from data obtained during the REMOTS® survey described in Section 3.2. An initial examination of the REMOTS data showed that this location was a highly stressed area composed of a 2-3 cm layer of coarse material and disarticulated mussel

shells overlaying a layer of what appeared to be anoxic dredged material extending below the penetration depth of the REMOTS® prism. The bottom in this area sloped quite dramatically to the southwest (Figure 3-2). Beginning at a depth of approximately 25 meters in the northeast, the depth increased to over 70 meters to the southwest (beyond the edge of the Master survey). These data, combined with a more detailed analysis of the REMOTS® survey, showed that this area would be unsuitable for use as a disposal point due to the apparent high kinetic energy of this location and the fact that it was located outside the disposal site boundary. A new disposal point was located in the central and eastern section of the disposal site (designated as NL-85) and baseline conditions prior to disposal operations were surveyed (NLON-85 survey area). The depth in this area (Figure 3-3) varied from approximately 16 meters over the NL-III disposal mound in the north central portion of the area down to greater than 23 meters in the southern portion of the site. Three disposal mounds (NL-I, NL-II, and NL-III) represented the most distinctive topographic feature of this area, while the ambient bottom tended to slope very gently to the south. The buoy was positioned so that the addition of a significant quantity of dredged material would tend to consolidate the three existing disposal mounds.

The results of the post-disposal bathymetric survey around the NL-85 disposal point (Figure 3-4) revealed the establishment of a mound of dredged material centered approximately 100m southeast of the disposal buoy. The height of the mound was approximately 2 meters and extended from 250 to 350 meters from the center (Figure 3-5). This mound was the result of the disposal of approximately 377,500 m³ (493,400 yd³) of dredged material, as estimated from the scow logs.

During the July 1986 Master survey, the bathymetric features (Figure 3-6) were identical to those seen during the August 1985 survey of the same area except for the addition of the NL-85 mound to the four older mounds (NL-RELIC, NL-I, NL-II, and NL-III). In order to determine small changes in bathymetry in the area of the five disposal mounds, another survey was conducted (NLON-86 survey in Figure 2-1) at a 25 m lane spacing. The contoured depth chart of this area (Figure 3-7) gives greater detail as to minimum depths of each mound as well as their areal extent. The NL-RELIC mound was the shallowest at a depth of approximately 13.5 meters. Mounds "NL-I", "NL-II", and "NL-III" had minimum depths of 15.5, 15.5, and 14.5 meters, respectively.

In order to compare the results of the July 1986 survey with those obtained in November 1985 (Figure 3-3) and January 1986 (Figure 3-4), the raw bathymetric data were regridded to match the survey designated as "NLON-85" in Figure 2-1. This encompassed the area of the most recent disposal operations. All the bathymetric features seen in the July 1986 survey (Figure 3-8) appeared identical to those seen in January, except for the increase in

depth near the peak of the mound on the order of 25 cm. This could be the result of erosion and/or consolidation.

Volume difference calculations were performed for the three NLON-85 surveys to estimate the amount of material involved in the detected changes in bathymetry. The volume of additional material determined by comparison of data from the November and January surveys was approximately 194,000 cubic meters. Scow logs for this period indicated that approximately 385,710 cubic meters of dredged material was deposited.

The difference in the two estimates is partially due to the overestimates from scow logs due to unknown amounts of water in the scow. In addition, dredged material at the flanks of the mound can occur in thin layers that are undetectable acoustically. Compaction of the material on the bottom prior to the post-disposal bathymetric survey can also significantly affect the estimate of the volume of deposited material.

A study was conducted by the New York District of the Corps of Engineers in 1980 at the Mud Dump Site in the New York Bight to determine the reduction in volume of dredged material from the initial dredging to disposal (Tavolaro, 1983). A comparison of carefully determined volumes of dredged material in the scows with the volume of material deposited at the disposal site, determined by pre- and post-disposal bathymetric surveys, indicated a reduction in volume of approximately 40.7%. Of this total, a volume loss of 15.4% was attributed to the dispersal of interstitial water during descent and initial self-compaction. It also has been estimated that approximately 7% can be attributed to further compaction of the material once on the bottom (Bokuniewicz et al., 1980). Bokuniewicz et al. determined that 50% of the total compaction will occur within one month of disposal and 100% within one year. The remaining reduction in volume is likely due to dredged material being deposited in thin layers that can't be detected acoustically.

Correcting the scow log estimates of 385,710 m³ by the 40.7% factor resulted in a volume of 228,726 m³, much closer to the 194,000 m³ calculated from the survey comparison of the November 1985 and January 1986 NLON-85 bathymetric surveys.

Comparison of the January and July surveys revealed an apparent reduction in volume of approximately 17,000 cubic meters at the NL-85 mound. NED scow logs for this period revealed that an additional 5720 m³ (7475 yd³) of material were dumped since January 1986 (28 March and 30 April 1986). To determine the significance of this estimated reduction in volume, the statistical error of this calculation was determined for the NLON-85 survey area. The NLON-85 survey was composed of 37 survey lanes (or rows) spaced 25m apart. Each lane was divided into 72 cells, each 12.5 meters wide. This configuration represented a grid of 2664 cells,

each 25 × 12.5m in area centered on a survey lane. Investigation of the various errors associated with the depth measurements, positioning ranges, and tide height corrections determined a standard error (s_c) for the depth value of any given cell to be approximately 0.15 meters. The standard error of a mean depth over the entire grid (s_g) equals:

$$s_g = \frac{s_c}{\sqrt{N}} \quad (1)$$

where N = the number of grid cells in the survey.

In order to calculate the difference in the volume of material between two surveys, one determines the number of grid cells at the left and right boundaries of the grid that are assumed not to have experienced changes in depth (ambient bottom). Because these cells are then defined as having the same depth in both surveys, equation (1) is modified to:

$$s_g = \frac{2(s_c)^2}{n} + \frac{2(s_c)^2}{m} = s_c \left(\frac{2}{n} + \frac{1}{m} \right) \quad (2)$$

where m = the number of cells on ambient bottom and assumed to be identical and
 n = the remaining cells ($n = N - m$) over the area suspected of changes in depth.

The standard error on the volume difference is calculated as:

$$s_v = s_g \times A \quad (3)$$

where A = the area of the survey in square meters.

For the present volume difference calculations, the 900 × 900 m survey area ($A = 810,000 \text{ m}^2$) had 37 × 72 cells ($N = 2664$). A total of 25 cells on each lane was determined to be on ambient bottom ($m = 25 \times 37 = 925$) leaving 47 cells on each lane ($n = 47 \times 37 = 1739$) to be compared for differences in depth.

Then,

$$s_g = s_c \left(\frac{2}{n} + \frac{1}{m} \right) = 0.15 \left(\frac{2}{1739} + \frac{1}{925} \right) = 0.0071 \text{ m}$$

and $s_v = s_g \times A = 0.0071 \text{ m} \times 810,000 \text{ m}^2 = 5739 \text{ m}^3$.

Therefore, the volume difference (V_d) of 17,000 m^3 for these surveys, calculated as the sum of the volume differences of each cell, had a standard error of 5739 m^3 . To insure the reliability of this estimated volume difference, 95% confidence

limits were calculated. This calculation simply implies that the actual (and unknown) volume difference will occur within the lower and upper confidence limits with a probability of 0.95. These limits (L_1 and L_2) are defined to be 1.96 standard errors to either side of estimated value (V_d):

$$L_1 = V_d - 1.96(s_v) = 17,000 - 1.96(5739) = 5754 \text{ m}^3,$$

$$L_2 = V_d + 1.96(s_v) = 17,000 + 1.96(5739) = 28250 \text{ m}^3.$$

Because this 95% confidence interval (L_1 to L_2) does not surround zero, the probability that the actual volume difference equals zero is very small and, therefore, indicates that a volume difference of between 5754 and 28,250 m^3 did occur. This apparent difference can represent post-depositional consolidation and compaction and/or erosion and dispersion. Our analysis does not allow separating these two processes. However, if one assumes the worst case (100% loss due to erosion and dispersion), the loss of 17,000 m^3 spread evenly over the 900 x 900 meter area compared (543,438 m^2) in the calculations would mean a change in depth of approximately only 3 cm.

3.2 Side Scan Sonar Survey

The results of the side scan survey conducted in August 1985 revealed two distinct areas of high acoustic reflectance. Areas of high reflectance denote areas of bottom where seafloor sediments have a high acoustic impedance, such as hard packed sand and/or rock. Past experience has shown that high reflectance areas are also indicative of recent disturbances in the bottom morphology as a result of disposal operations. The side scan sonar survey is a useful reconnaissance method to determine the spatial distribution of dredged material, but the final determination of bottom composition must be accomplished using other techniques. The results of the side scan survey (Figure 3-9) indicated high acoustic reflectance material in two distinct areas. The area labeled "AREA 1" corresponds to the locations of the NL-I, NL-II, and NL-III disposal mounds. The NL-RELIC disposal mound was dredged by the Corps of Engineers in the spring of 1984, to reduce the elevation of the mound, and the impressions left by the dredge's suction head were clearly evident (Figure 3-10). The other area of high acoustic reflectance (AREA II in Figure 3-9) was noted in the southwest portion of the side scan sonar survey. Data collected during the REMOTS® survey (see Section 3.3) suggested that this may be dredged material.

3.3 REMOTS® Sediment-Profile Photography

July 1985 Survey

Most of the sediment surface consisted of medium to very fine sands (Figure 3-11). Sorting appeared to be poor; several subordinate grain-size modes (both finer and coarser) were mixed into these sediments. In addition, these surface sands were superimposed over silt-clay muds (>4 phi) throughout much of the site. It is possible that subsurface mud extended over the whole area. If the surface sand layer was thicker than the camera prism penetration depth, only the surface grain-size was apparent in the photographs. In general, the finest sediments (very fine sand) were located along the northern and southern boundaries of the area. Local patches of coarse sand and cobble-sized (<-1 phi) sediment were located in the center of the disposal site. This coarse material may have represented dredged material. Two large areas predominated by fine to medium sands were located in the northern and southwestern portions of the survey area (Figure 3-11). Strong kinetic gradients could occur along the borders of these regions.

Photographs from four stations in this survey indicated the presence of dredged material (Figure 3-11). Only one station (F-13), exhibiting a buried RPD layer (indicative of a dredged material deposit), was located outside the disposal site. However, dredged material could have been more widespread than indicated. Due to the relatively coarse nature of sediments at the New London site, REMOTS® prism penetration was shallow (i.e., less than 8 cm) at many stations. Consequently, buried redox layers were not evident in the photographs at stations G-7 and G-9 (Figure 3-11). Two regions, the southwest and northeast corner of the surveyed area, exhibited highly reduced sediments (Figure 3-12). This reflected either the presence of dredged material or high natural organic enrichment.

Most of the boundary roughness values for the stations at New London ranged from 0.2 to 1.6 cm (Figure 3-13). Roughness values greater than 0.8 cm represent stations where large disarticulated mollusc shells, many fouled by epifauna, occurred on the bottom. These stations were located near the western and southern edges of the surveyed area.

The observed RPD values were low compared with other DAMOS sites. Fifty-eight stations exhibited no or extremely shallow (i.e., less than 1 cm) RPD's (Figures 3-13 and 3-14). These sites were concentrated along the northern edge and in the southeast corner of the surveyed area. These shallow RPD depths appeared to be related to low concentrations of dissolved oxygen in bottom waters. This hypoxic bottom-water condition likely represented the "August Effect" (Rhoads and Germano, 1982): high

water temperatures, a stratified water column, and high rates of benthic metabolism (high BOD and COD). This August Effect has been documented for sub-estuaries of Long Island Sound such as New Haven Harbor and Bridgeport Harbor but has not been observed at the NLON Disposal Site. Further evidence of hypoxic bottom conditions occurred when SAIC scientists on board the research vessel observed dense aggregations of the amphipod Ampelisca swimming at the air/water interface. Amphipods only leave the bottom and their tubes to exhibit this type of behavior when there is severe low dissolved oxygen stress in bottom waters. This seasonal stress factor may have a major influence on the recolonization of disposal mounds at the New London Disposal Site.

The RPD values greater than 3 cm were located in two large patches in the center of the disposal site (Figure 3-14) and included the disposal mounds themselves. These patches were elongated in a NE-SW direction. This pattern may be related to the region's bathymetric gradients and bottom current regime (see Figure 3-1).

Much of the site was dominated by an extensive mat of tubicolous amphipods (Ampelisca sp., indicated as Stage II in Figure 3-15). Many of these tube mats appeared disturbed; the tube mats were rolled up into mud clasts. Other mats showed evidence of decomposition of the tubes, apparently related to death of the amphipods and subsequent microbial decay of the binding organic matrices (Figure 3-16). These features indicated a retrograde Stage II sere. In many cases, this retrograde status was likely related to the apparent low bottom-water oxygen levels. Conversely, some photographs showed apparently healthy Stage II tube mats (Figure 3-17). The largest area of viable amphipods fell within that area of the bottom where apparent RPD depths were greater than 3 cm which again included the areas of the disposal mounds.

Most of the region also exhibited evidence of Stage III infauna (Figure 3-15). When these deep-dwelling, head-down feeders were clearly evident below the Stage II mats, the successional stage was classified as a Stage II on III (indicated by the symbol III-II in Figure 3-15). Alternatively, some photographs revealed less definitive evidence of Stage III infauna (Figure 3-18). These were considered transitional between Stage II and III and were symbolized by a II--III in Figure 3-15. The areas which lacked any evidence of Stage III infauna (hatched areas in Figure 3-15) were largely restricted to the borders of the survey area and, in general, overlapped the regions of suspected hypoxic bottom water conditions.

In addition to infauna, the surface of several stations exhibited hydroids and/or large disarticulated bivalve shells which, in turn, served as a surface for the attachment of

epibionts. This phenomenon was most frequently encountered along the southern and western edge of the region.

Areas with OSI values greater than +6 (hatched areas in Figure 3-19) represented the least "disturbed" benthic regions and included the majority of the disposal mounds. The remainder of the site exhibited relatively low OSI values (+6 or less). To a large degree, these low OSI's reflect the shallow, or zero, RPD values. Given that the most stressed areas were located along the margins of the disposal site, this "disturbance" did not appear to be related to the disposal operations. The bimodal OSI distribution (Figure 3-13), with modes centered at values of 0 and +8, reflects the dichotomy in benthic conditions apparently arising from the patchy distribution of hypoxic conditions.

August 1985 Survey

A significant gradient in sediment properties was found to extend east to west across the southwest survey area (Figure 3-20). Five sedimentary facies (A through E) were recognized. Facies A consisted of a medium sand (2-1 phi) containing many mollusc shell fragments. This was surrounded by coarse sand (1-0 phi), very coarse sand (0 to -1 phi), and granule (-1 to -2 phi) skeletal arenites (i.e., sands, Facies C). The surface of the sediment in Facies B consisted entirely of Zostera marina (eelgrass) detritus. Facies D was composed of a rippled shell-rich medium sand (possible evidence of deposited dredged material). This sand was apparently being transported westward over a mud bottom (>4 phi) identified as Facies E. From these facies relationships, one may construct kinetic gradients. Facies B was the lowest kinetic area, being a repository for low density organic detritus. The highest kinetic area was represented by the coarse sand to granule skeletal sands. The transgression of the medium sands of Facies D westward over the muds of Facies E indicated that this was the direction of net transport and that a strong kinetic gradient exists in this direction. Not surprisingly, the direction of this transport corresponds with the bathymetric gradient present in the area (see Figure 3-1). Overall, this area southwest of the disposal site appears to be dispersive.

The small-scale boundary roughness frequency distribution shows that most of the values fell within the 0.4 to 0.8 cm modes (Figure 3-21). This relief reflects the presence of small sand ripples. The larger roughness values reflect the presence of blue mussel Mytilus edulis at the sediment surface, particularly in Facies E.

Because of the shallow penetration depths of the camera prism due to coarse sediments and shell deposits over much of the area, values for RPD depth were only available for 8 of the 25 stations (Figure 3-22). These stations were restricted to the

northeast corner of the sample grid. Compared to the overall region surveyed in July, the RPD values measured at these stations in the southwest survey area were relatively high, with a major mode at 3 cm (Figure 3-21) as compared with a major mode of 2 cm in July (Figure 3-13).

The shallow REMOTS® prism penetration also precluded the accurate assessment of infaunal successional stage across most of the southwest survey area. Where sufficient penetration was obtained (in the northeast quadrant), Stage III infauna were widespread (Figure 3-23). To the southwest, the region appeared to be dominated by epifauna, mainly Mytilus edulis. This mussel bed was apparently the source of much of the shell detritus associated with the sandy sediments in the area.

Organism-Sediment Index values could only be calculated at those stations where RPD depth and infaunal successional stage could be determined. Again, these stations were restricted to the northeast corner of the sample grid (Figure 3-24). The indices ranged widely in value (Figure 3-21), indicative of a patchy benthic environment.

Overall, the region southwest of the disposal site surveyed in August was not suitable as a containment disposal point. This area had generally high kinetic energy with net bottom transport apparently occurring downslope (northeast to southwest). Due to these findings, an alternative disposal point was selected and surveyed in November 1985.

November 1985 Survey

An area located in the central and eastern portion of the New London Disposal Site (Figure 2-1) was surveyed in November 1985 to locate a new disposal location. The entire area consisted of a thin sand layer (less than 1 to 3 cm) overlying a silty mud (>4 phi, Figure 3-25). This sediment distribution corresponded to the results of the July survey from this region. The surface material ranged from very fine to medium sands. In general, the coarsest material occurred in the western half of this survey grid and may have represented disposed materials. Surface shell lag deposits were also evident throughout the area. The relatively large boundary roughness values were related to the presence of large disarticulated mollusc shells on the surface, tubicolous amphipod mounds, and mud clasts.

The mapped distribution of the apparent RPD depths (Figure 3-26) suggests that an apparently hypoxic layer existed along the southernmost transect. This may be related to the region's bathymetry; this southern portion represents the deepest region surveyed (Figure 3-3). It is noteworthy that this apparent low oxygen bottom water condition was observed in November. In

July, relatively large areas along the margins of the entire New London Disposal Site were apparently hypoxic. Although the sediment was apparently reduced close to the sediment surface, the overlying water column in November could have contained high concentrations of dissolved oxygen. One may expect a time lag between re-aeration of the bottom waters and irrigation and aeration of the sediment column. North of this area, RPD depths were relatively well-developed. The frequency distribution of RPD values (Figure 3-27) illustrates this dichotomy in bottom oxygen levels. The bimodal distribution reflects the presence of both aerobic and hypoxic areas.

Surface tube mats of Stage II fauna (the amphipod Ampelisca sp.) were evident across most of the survey grid (Figure 3-28). Along the southern, apparently hypoxic, region, the amphipod mats appeared to be in various stages of decomposition and erosion (Figure 3-29). Evidence of Stage III seres (head-down deposit feeders) was also widespread across the survey grid. Only three stations, two of which occurred along the southern transect, lacked evidence of high-order successional infauna (hatched region in Figure 3-28). Overall, the infaunal successional status of this area coincided with the pattern observed in July. Excluding the area which was apparently subject to severe oxygen stress, animal-sediment interactions at the site were generally well-developed.

Negative OSI values were calculated for stations along the southern edge of the mapped area and reflected the apparent hypoxic conditions (Figure 3-30). The remainder of the site consisted of a wide range of index values indicative of a heterogeneous benthic environment. The OSI frequency distribution (Figure 3-27) further illustrates this diversity; OSI values ranged from -3 to +11. Overall, the OSI values observed at this small survey site in November reflected the OSI values observed across the entire New London Disposal Site in July.

January 1986 Survey

An immediate post-disposal REMOTS® survey of the NLON-85 area characterized in November was performed on 24 January 1986. The main objective of this survey was to delimit the distribution of newly disposed dredged material (scow log estimate = 377,500 m³). The new disposal mound was designated "NL-85".

The distribution and thickness of dredged material layers evident in the REMOTS® photographs (Figure 3-31) indicated that the disposal mound was offset to the southeast relative to the center of the disposal point. Dredged material extended to stations 500E, 500S, 300N, and 300W. As observed in the post-disposal survey at the Field Verification Program (FVP) disposal mound at the Central Long Island Sound Disposal Site (CLIS), much of the area of

seafloor affected by the disposal operation was overlain by relatively thin dredged material layers (ranging from 0 to 10 cm in thickness; Figure 3-32).

Most of the site consisted of silt-clay and very fine sand mixtures (>4-3 phi, Figure 3-31); in large part, this reflected the texture of the disposed materials. Beyond the disposal mound to the north and west, more coarse-grained sediment was evident (fine to medium sands). Cobbles were also present at several of these sandy stations. The boundary roughness values had not changed significantly since the November survey (compare Figure 3-33 with Figure 3-27; Mann-Whitney U-test, $p = 0.482$). The disposal operations apparently did not alter small-scale topographic relief in the area.

As expected, the RPD depths significantly decreased since the pre-disposal survey (Mann-Whitney U-test, $p = 0.006$, Figure 3-33). Fifty-four percent of the RPD depths were less than 1 cm (Figures 3-34 and 3-35); the spatial distribution of these extremely shallow RPD's corresponded to the distribution of dredged material. Beyond the disposal mound, RPD depths were similar to those observed in November. Also, there was no evidence of the apparent bottom hypoxia or high sediment oxygen demand which was observed in the southern portion of the region in November.

In contrast to the November results, Stage III seres were not evident in the central portion of the region (hatched area in Figure 3-36). This was a direct result of the disposal operations. Stage III infauna were evident on the flanks of the mound. The rapid re-establishment of high-order successional taxa on the flanks of the mound indicates that recolonization occurred through lateral or vertical migration of these infaunal organisms. Beyond the apparent influence of the disposal operation, both Stage II and Stage III seres were evident. This represents the pre-disposal successional status of the site.

The central portion of the disposal mound exhibited low OSI values (Figure 3-37) due to the extremely shallow RPD depths and the low-order successional status. The least disturbed region occurred north of station 200N. In contrast to the November results (see Figures 3-27 and 3-30), there were no negative OSI values (Figures 3-33 and 3-37); this was because hypoxic conditions may no longer have been apparent at the site. The polymodal OSI frequency distribution (Figure 3-33) illustrates the three habitats present at the site. The modal value at +2 represents the central disposal region which exhibited extremely shallow RPD depths and lacked Stage III infauna; the mode at +6 reflects stations on the disposal mound flanks which exhibited shallow RPD's, but had been recolonized at depth by high-order successional infauna; and the mode at 10 represents the surrounding seafloor which was unaffected by the disposal operations.

July 1986 Survey

The July 1986 survey included individual sampling grids at each of the five disposal mounds as well as at the southwest corner of the disposal site to detect the presence of dredged material outside the site boundaries. Distinct dredged material layers were evident in the vicinity of the NL-85 disposal point (Figures 3-38 and 3-39). The perimeter of the NL-85 mound was similar to that observed in January 1986, with the exception of station 500E. In January, station 500E exhibited a dredged material layer 3.29 cm thick. In this survey, dredged material was not detected at station 500E. This may be explained either by local patchiness near the edge of the mound or by bioturbational mixing of the thin flanks of the deposit. Such mixing can erase evidence of a pre-existing surface layer of deposited material, especially when it is thin relative to the mean particle bioturbation depth. This phenomenon was documented at the flanks of the Field Verification Program (FVP) mound at CLIS during the first year of monitoring (Germano and Rhoads, 1984). The apparent absence of dredged material at all stations immediately adjacent to the NL-85 disposal mound indicated that either no dispersal of material from the mound to the surrounding bottom had occurred or that the disposed material was so thin that it could not be detected in the REMOTS® photographs. In the past, dredged material layers as thin as 0.1 cm have been detected. If thin layers of dredged material were deposited, however, rapid bioturbation can mix such layers with the underlying (ambient) sediments. For these reasons, the designation of "NDM" in Figure 3-38 indicates that the REMOTS® photographs contained no definitive information about the presence of dredged material. Such material may have been present in small quantities. No dredged material was observed at the New London Reference station. In addition, dredged material was not detected at any stations in the southwest reconnaissance grid.

Surface sediments at most stations within the disposal site consisted of very fine to fine sand (4-3 phi to 3-2 phi, Figure 3-40). At the other stations where the sediment grain-size major mode was silt-clay (≥ 4 phi), all but one were comprised of thin sand layers overlying fine-grained sediments (see Figure 3-38). Eighteen of the twenty replicates taken at the Reference station showed a major mode of fine sand (3-2 phi), while two replicates exhibited very fine sand (4-3 phi). The relatively diverse and layered distribution of sediment grain-size at the New London Disposal Site likely reflected inputs of heterogeneous dredged material, as well as diverse ambient bottom textures.

The western side of the southwest reconnaissance grid consisted of medium sand (2-1 phi) and the eastern side consisted of predominantly coarse sand (1-0 phi, Figure 3-41). Unlike the disposal site, the sediment grain size samples in this area consisted largely of bivalve shell fragments derived from venerid

clams and the mussel Mytilis edulis. As indicated by the results of the REMOTS® July 1985 survey, this region southwest of the disposal site appeared to be a relatively high-kinetic area characterized by surface shell lag layers (Figure 3-42).

The frequency distributions of boundary roughness values were determined for all stations within the disposal site (NL-85, NL-III, NL-II, NL-I, and NL-RELIC, Figure 3-43a), for the NL-85 mound only (Figure 3-43b), for the Reference station (Figure 3-43c), and for the southwest reconnaissance grid (Figure 3-43d). The major mode in each case was centered at 0.80 cm. There was no significant difference between the boundary roughness values at the entire disposal site and the Reference station (Mann Whitney U-test; $p = 0.6877$), or between the NL-85 disposal mound and the Reference station (Mann Whitney U-test: $p = 0.4643$). Also, there was no change in small-scale bottom roughness at the NL-85 mound since the January 1986 survey (Mann-Whitney U-test; $p = 0.5357$). The lack of change in small-scale surface topography at the NL-85 mound indicated that the minor disposal activity since January had little or no impact. Overall, the highest roughness values were recorded in the southwest grid; this was related to the presence of large shell fragments at the sediment surface in this region.

Stations in the southeast portion of the NL-85 mound had relatively low apparent RPD values (Figure 3-44). This area of shallow RPD depths overlapped both disposed materials and some ambient bottom stations. This affected area was generally below the 19 meter isobath (Figure 3-7), while the rest of the mound was located in shallower water. The shallow mean apparent RPD's could have been related to a high sediment oxygen demand or a limited supply of oxygen to these sediments. In the July 1985 REMOTS® survey of the New London Disposal Site, the southeast corner (and northern edge) of the site had shallow, or absent, apparent RPD depths which were either very shallow or equal to zero (i.e., no oxidized sediment layer). The southeast corner of the site was again observed to have anomalously shallow oxidized layers in the November 1985 survey. During the July 1986 survey, seven stations showed shallow RPD depths along the northern edge of the disposal site. It is unclear if these few stations represented general hypoxic water conditions along the northern perimeter of the site or if these low RPD values represented locally high sediment oxygen demands. Much of the southwest survey grid also was marked by shallow apparent RPD depths (Figure 3-45). This outlying area occurred at greater depths relative to the disposal site.

The apparent RPD values from all stations in the disposal site (Figure 3-46a), as well as just the NL-85 mound (Figure 3-46b), were not significantly different from the Reference station values (Figure 3-46c, Mann-Whitney U-tests; $p = 0.6303$ and 0.6885 , respectively). However, the NL-85 RPD values have significantly deepened since the January post-disposal REMOTS® survey (Mann-Whitney U-test; $p = 0.001$). This reflects the effects of

colonizing benthos on pore water chemistry through tube and burrow irrigation.

At the NL-85 disposal mound, the lowest successional seres were found in the southeast quadrant (Figure 3-47); this generally coincided with the areas exhibiting shallow apparent RPD depths. Stage II (*Ampelisca* sp.) seres were evident in over half of the stations located on the NL-85 mound (Figure 3-48). This assemblage also dominated in the NL-85 baseline study conducted in November 1985. At the Reference station, evidence of Stage III infauna was present in 11 of the 20 photographs. Stage II assemblages (amphipod tube mats) were also evident in 18 of the 20 reference photographs. All of the amphipod tube mats at the Reference station, however, appeared to be physically disturbed, with many of the tubes lying flat on the bottom or rolled up into aggregates (Figure 3-49). The apparently retrograde condition for this assemblage may have been a result of local physical factors and/or biogenic disturbances, such as large-scale bioturbational mixing by Stage III infauna or foraging by epibenthic predators. All twenty Reference photographs also showed the presence of hydroids and/or small mussels at the sediment surface (Figure 3-49). The REMOTS® photographs from the NL-I mound and the portions of the NL-RELIC, NL-II and NL-III mounds which were sampled showed widespread evidence of Stage III infauna, similar to the Reference station in contrast to that observed at the NL-85 mound. Also, mussels were seen at center and 200E of mound NL-I. The presence of the high-order successional seres at these mounds indicated the absence of recent disturbances. In July 1986, disposal operations had not occurred at these mounds for several years (the most recent occurred at NL-III in 1984).

Because of shallow camera prism penetration depth caused by the high shell content of the sediment and high shell density at the sediment-water interface, it was not possible to determine the successional status in many of the photographs at the southwest reconnaissance grid (Figure 3-50). The northern and southern edges of the site appeared to be populated by Stage I polychaetes. Hydroids were again common because the abundance of shell fragments provided solid surfaces for their attachment. This area appeared to experience periodic (or chronic) physical disturbance related to the transport of shell debris from the northeast (upslope).

The northern and western flanks of the NL-85 disposal mound exhibited relatively high OSI's (Figure 3-51), which indicate rapid recolonization. Conversely, most of the central area and eastern edge of the mound exhibited relatively low OSI values (< +6). An OSI value of less than or equal to +6 generally indicates bottoms that are either recently disturbed or in a low order successional stage. In November 1985 (predisposal survey), the NL-85 disposal point showed generally high OSI values, except in the extreme southeast quadrant. This gradient was attributed to the low oxygen conditions which apparently developed in the deeper

region to the southeast. This oxygen stress may have been inhibiting benthic recolonization in the southeast portion of the disposal mound. At the New London Disposal Site, overall, the highest OSI values were to be associated with NL-I; this mound has not received dredged material since 1977 and (according to the July 1985 REMOTS® survey) this area did not experience late summer hypoxic conditions. The OSI map of the southwest grid (Figure 3-52) provides only a few values from the northern and southern edges of the surveyed area because of the shallow prism penetration and dense shell aggregations at the sediment surface. All of the mapped values were below the threshold value of +6; this apparently reflected local physical disturbance factors.

The distribution of OSI values for all stations combined (Figure 3-53a) was not significantly different from the Reference station (Figure 3-53c, Mann-Whitney U-test; $p = 0.2973$). Similarly, OSI values at the NL-85 mound (Figure 3-53b) did not significantly differ from the Reference station ($p = 0.6753$). The NL-85 mound had significantly higher indices than recorded in the January 1986 post-disposal survey ($p = 0.006$). This indicates that the NL-85 mound was experiencing successful colonization, particularly at its northern and western flanks. The slower colonization rate in the SE quadrant most likely was related to the presence of hypoxic bottom water in this area.

3.4 Sediment Characteristics

All of the sediment samples collected in the area southwest of the New London Disposal Site during the August 1985 survey were composed of a large number of disarticulated mussel shells on the surface of a 2-4 cm layer of medium to fine sand (Table 3-1). Samples taken from stations C-13 and E-14 contained small amounts of black anoxic sediment. Past experience at locations within the central portion of the disposal site has shown that the ambient bottom normally is composed of a thin (2-3cm) layer of fine sand laying over a cohesive layer of clayey silt, (several vibracores taken at the site in December 1983 confirmed this interpretation and indicated that the clay layer typically extends down to a depth in excess of 4 meters). The higher concentrations of all the metals and oil and grease found at stations C-13 and E-14 (Table 3-2) suggest the presence of dredged material.

During the July 1986 survey, sediment samples were collected at the five disposal mounds and at the Reference station. The sediment on the disposal mounds was either organic silt or silty sand (Table 3-3) while the Reference station contained only silty sand. Some variability can be seen in the size class data for replicate samples from the same mound and between the top and bottom samples. Where detectable levels were reported for the chemical composition of the replicates (Table 3-4), a mean and

standard deviation were calculated. The exception to this was for the PCB analyses. Both sections of the core were combined and only a single analysis was conducted.

Statistical tests were performed to determine if the concentrations of contaminants were different at each of the five disposal mounds compared to the Reference station concentrations (Tables 3-5 and 3-6) and also to see if there were significant differences between the top core section (0-2 cm) and bottom section concentrations (Table 3-7). For PCBs, only a single analysis was conducted for each station, therefore the PCB concentrations between stations could not be compared statistically. Because total carbon is a more informative measure of increased organic matter input compared to total hydrogen or total nitrogen, only this value was compared statistically among stations. Cadmium and nickel were below the analytical detection limits in most samples and were not tested. In most cases, the concentrations of contaminants were significantly ($p < 0.05$, Mann-Whitney U-test) higher at the five test stations (NL-85, NL-I, NL-II, NL-III and NL-RELIC) than at the Reference station. This is true for both the core tops and bottoms (Tables 3-5 and 3-6). Zinc, chromium, and copper concentrations were elevated in the bottom sections of cores from each of the five disposal mounds compared to the Reference station concentrations. In the top core sections this was also true except that zinc was not higher in the NL-II core sections and chromium concentrations were not elevated in the NL-III sections. In the top core sections from the NL-RELIC station, all parameters except arsenic, total carbon, and oil and grease were significantly elevated and all but arsenic were elevated in the bottom sections of these cores. For the remainder of the parameters, no consistent trends in the data could be identified. Comparison of the top 2 cm core sections with the 2-10 cm sections did not reveal any consistent trend in elevated levels of contaminant. In only six cases (out of 42, Table 3-7) did a chemical concentration differ significantly between the top and bottom core sections.

3.5 Benthic Community Analysis

The sieve residue from the samples collected at the Reference station in November 1985 contained thousands of amphipod tubes and little or no sand and gravel. The residue from the sample collected at the center of the NL-85 mound contained up to 1 liter of sand, gravel, and large shells. Five species were in common among the top ten abundant species at both stations: the amphipods Ampelisca and Unciola and the polychaetes Mediomastus, Owenia and Tharyx (Table 3-8). Taxa were also identified as being exclusively found at one station or the other (Table 3-9). The effects of grain size, feeding competition, depth, and prey availability most likely all played a role in this segregation. Both suspension feeders and deposit feeders occurred

as dominant species at both stations. The presence of sedentary deposit feeding polychaetes like Pista and Polycirrus at the NL-85 station indicated that the substrate was relatively stable and that fine grained organic matter was available.

Ampelisca vadorum dominated both stations in terms of numbers (Table 3-8), making up 47% and 91% of individuals at the NL-85 station and the Reference station, respectively (Tables 3-10 and 3-11). Ampelisca dominated the Reference station physically; the fine sand substrate was covered with a continuous mat of amphipod tubes of all sizes. All co-occurring species must live on or under this mat and deal with the suspension feeding activities of the amphipods. The time of year contributed to this high density; as young adults and juveniles of the overwintering generation which were born during the late summer and early fall had not yet suffered losses from predation and winter storms. Most of the Ampelisca were 1-2mm long and 63% passed through a 1mm sieve.

The total number of species recovered from both stations (112, Table 3-11) was large for the small number of samples taken. The total was increased by the fact that two contrasting habitats were sampled. Sixty-five species were recovered from a single sample at NL-85. The species number per sample was also high (mean of 55 at NL-85, 52 at Reference). This level is typical of shallow shelf waters, such as Rhode Island Sound and Massachusetts Bay, but is higher than the 25 or 30 species normally found in Southern New England estuaries.

The benthic community was also characterized in sediment samples collected at the NL-85 disposal mound and the Reference station in July 1986. The sieve residues from the Reference station samples consisted of 1,500-2,200 cm³ of coarse gray sand, pebbles, shells, and both large and small ampeliscid amphipod tubes. The shells were weathered and belonged to species normally found in offshore habitats. Sieve residue volume from the NL-85 mound ranged from 250-380 cm³ and contained coarse gray sand and many small ampeliscid amphipod tubes. These residues were quite visible in the sediment samples prior to sieving on the research vessel (Table 3-12).

Following preservation and storage of the benthic samples, the shells of small individuals of several species of gastropods had dissolved in the preservative. In most cases, species were recognizable by comparison of soft parts and operculae with intact specimens. In several cases, very small or fragmented organisms were identified by reference to the archived 1985 samples.

The species at both the Reference and NL-85 mound stations were distributed relatively evenly among the major taxa. Individuals were distributed evenly among taxa at the Reference

station, however the NL-85 station was dominated by crustaceans (Table 3-13). The Reference station had three times as many species and twice as many individuals as the NL-85 mound station (Table 3-14). The Reference station also had ten times as many non-Ampelisca individuals. Ampelisca vadorum was the most numerous species at both stations and was found in similar densities (Table 3-15). There was a difference in biomass; only juveniles were found at the NL-85 station and both adults and juveniles were found at the Reference station.

The abundant mussel Musculus niger at the Reference station were all juveniles about 3 mm long. The small tube-dwelling spionid polychaete Prionospio steenstrupi was important at both stations as were the burrow-inhabiting amphipods Leptocheirus pinguis and Unciola irrorata. Many of the remaining dominants at the Reference station were polychaetes (Tharyx spp., Mediomastus ambiseta, Clymenella zonalis, Ampharete arctica, Harmothoe extenuata, and Aricidea jeffreysii). Many of the individuals in these samples were small in size. These included small species such as Skeneopsis planorbis, Turbonilla interrupta, Protodorvillea kefersteini, syllids, and Corophium spp. as well as juveniles of larger species such as the molluscs Lunatia triseriata, Crepidula spp., Anadara transversa, Ensis directus, the polychaetes Clymenella spp., Aglaophamus circinata, Harmothoe extenuata, and sabellids. All Cancer irroratus (sand crab) were less than 10 mm in carapace width. An asteroid about 1 mm in diameter was too undifferentiated to identify.

The dominants at the NL-85 mound station were all suspension feeders. At the Reference station, M. niger was also a suspension feeder. Tharyx spp., M. ambiseta, Oligochaeta, C. zonalis, H. arctica, and A. jeffreysii are all deposit feeders. H. extenuata is a scavenger/predator. There were many predators present among the subdominants at the Reference station. These included the gastropods Anachis, Lunatia, Mitrella, and Urosalpinx, all rhynchocoels, and the polychaete family Phyllodocidae.

Most of the species recovered in this study were typical of larger estuaries and the nearshore shelf of southern New England. The bivalve Hiatella arctica is usually found in offshore or northern waters. Polydora ligni, Mulinia lateralis, Ensis directus, and Mysella planulata, usually found in shallower, more estuarine waters, occurred in very low numbers.

3.6 Body Burden Analysis

The concentrations of eight trace metals (arsenic, lead, zinc, chromium, copper, cadmium, mercury and iron) and PCBs were measured in samples of the bivalve Pitar morrhuana collected at the New London Disposal Site in July 1986 (Tables 3-16, 3-17, and 3-18). Statistical analyses (Mann-Whitney U-test) were conducted on

the results to elucidate differences between contaminant levels in organisms collected from the two stations. Results of these tests indicated that there were no statistically significant differences in the tissue levels of any of the trace metals measured between the two stations at the $p < 0.05$ level. In all samples, the PCB concentrations were below the analytical detection limits (Table 3-18).

3.7 In-situ Diver Observations

Photo documentation (Figures 3-54 to 3-63) and visual counts (Table 3-19) were employed to characterize four areas at the New London Disposal Site in July 1986. A diver transect over the central NL-I disposal mound (see Figure 2-4) showed that the surface of the recolonized dredged material was flat and smooth with no distinguishable mounds or contours resulting from individual scow loads of material. The area had a high number of mud burrows caused by lobster excavations (Figures 3-54 to 3-56). Extensive finfish (sea robins, winter flounder, skate) foraging depressions were also evident on the sediment surface.

An observational dive in the northwest sector of the disposal site revealed that the surface sediments in this area consisted of a compact sand-silt-clay matrix ubiquitously covered with mats of amphipod tubes (Figure 3-59). Intermittent bare patches were apparently caused by fish and crustacean foraging activities. The overall area had relatively low topographic relief (less than 1 m) with occasional bowl shaped depressions up to 2 m in diameter. Lobsters and crabs were noted burrowing under debris (Figures 3-55 and 3-56) such as metal cables and rigid metal bars. Seven lobster burrows were observed excavated into the bottom where slight topographic rises occurred.

As in the northwest sector, the surface sediments in the northeast sector consisted of a compact sand-silt-clay matrix again carpeted with amphipod tubes. Occasional bare patches caused by foraging activities also were noted in this area. Small surface depressions (less than 25 cm in diameter and less than 10-15 cm in depth) were created as the result of crustacean (probably Cancer sp.) foraging. Four lobster burrows were noted in this area and old crustacean "grotto" structures were eroding and unoccupied.

The conditions existing at the mussel beds in the southwest sector of the disposal site consisted of compact silt/sand with dense amphipod tube cover. Occasional excavations approximately 0.5 m in diameter and 3-5 cm deep indicative of crustacean foraging were noted in this area. Shell cover was less than 2%, with Mytilus predominating. The bottom topography was flat, and obstructions consisting of wire cable and pipe were observed. In addition, a large number of lobster burrows (greater than 12) were observed.

4.0 DISCUSSION

The NLON Master bathymetric survey was conducted in 1985 and 1986 along with REMOTS® sediment profile surveys extending beyond the disposal site boundaries in 1985 and at each of the five disposal mounds in 1986. The purpose of these surveys was to detect any evidence of significant dispersion of dredged material and subsequent environmental impacts related to disposal. Comparison of the 1985 and 1986 Master bathymetric surveys did not reveal any significant changes in bottom topography, except where the NL-85 mound was established (see below for further discussion). The minimum depths at the peaks of the NL-I, NL-II, NL-III, and NL-RELIC mounds remained essentially unchanged.

Results of the analysis of REMOTS® photographs obtained during the July 1985 field investigation at the New London Disposal Site suggested that dredged material may have been present beyond the margins of the southwestern quadrant of the disposal site, apparently due to the stressed conditions there. This area was being considered as a new disposal location. Due to the coarse nature of the sediments, shallow camera penetration depths prevented the detection of buried redox layers at several stations. The side scan sonar survey performed in August 1985 indicated an area of high acoustic reflectance outside the southwest border, also suggesting the presence of dredged material. However, high reflectance is also characteristic of coarse-grained sediment. The high concentrations of metals and oil and grease in the sediment at stations C-13 and E-14 in the July 1985 survey contrasted sharply with the lower concentrations of the other three stations further south and west, also indicating the possible presence of dredged material.

REMOTS® and precision bathymetric surveys were conducted in the southwest quadrant extending outside the disposal site boundaries again in August 1985. Analysis of these REMOTS® photographs did not detect the presence of dredged material. Additional stations were surveyed in the southwest area in July 1986 to further investigate the possible presence of dredged material. Close examination of the REMOTS® photographs from the 24 stations in this southwest reconnaissance grid, which extended the range of the area previously surveyed in July 1985, revealed that no apparent dredged material was present. This area corresponds to a bathymetric gradient increasing from northeast to the southwest; the photographs suggested that this is a high-kinetic area with surface shell lag layers. There was no evidence of dredged material dispersing beyond the perimeter mapped in the July 1985 survey. No other areas outside the disposal site boundaries were suspected of containing dredged material.

The steeply sloping bottom topography and the apparent high kinetic energy of the southwest quadrant made it unacceptable

for the disposal of dredged material. A new disposal point was chosen (designated NL-85) approximately 500 meters east of the center of the New London Disposal Site. This location was characterized by a fairly flat area at the center covered with amphipod tube mats and shell hash. Immediately north were mounds from previous disposal activities. It was predicted that disposal at this new location would result in the containment of the dredged material in this localized area. Coarse material was found in the northwest quadrant of the NLON-85 survey area, probably indicating the presence of dredged material from disposal operations at the existing mounds (NL-RELIC and/or NL-III).

The survey conducted in January 1986 at the NL-85 disposal mound (post-disposal) included precision bathymetry and REMOTS® sediment profiling. Results of the analysis of the bathymetric data indicated that significant changes in depth (>10 cm) occurred as far as 350 meters from the center of the mound (created since the November 1985 survey). Dredged material was seen in the REMOTS® photographs as far as 500 meters from the mound center in layers less than 10 cm thick. These thin layers extended slightly beyond the eastern boundary of the disposal site (Figure 3-31). The mound had a maximum thickness of approximately 2 meters and a volume of about 194,000 m³, based on the comparison of the November 1985 and January 1986 bathymetric surveys. Recolonization of Stage III infauna by lateral or vertical migration was evident on the fringes of the mound.

The results of the survey conducted around the NL-85 disposal mound in July 1986 indicated a small reduction in volume of dredged material when compared to the January 1986 survey. The minimum depth at the NL-85 mound increased by up to 20 cm. This deepening could have been the result of erosion, compaction, consolidation, subsidence, or a combination of these processes. Examination of REMOTS® photographs from the NL-85 mound in July 1986 did not detect any large scale erosional features (e.g., shell lag deposits, truncated RPD's, or mud clasts) that could account for this reduction in volume. The topography at the NL-III mound (also included in the NLON-85 survey area) did not change between the January and July surveys as verified by almost perfect alignment of similar depth contours. This was also true for other topographic features in the survey area, indicating good agreement of the two surveys compared to calculate the change in volume. The quasi-fluid nature of a portion of the newly deposited dredged material makes it more vulnerable to erosional processes than previously deposited material. However, because no evidence of erosion was detected in the REMOTS® photographs, the most parsimonious explanation for the slight depth increase is consolidation. The July 1986 REMOTS® results also indicated that very thin layers of dredged material occurred in a very small area beyond the eastern disposal site boundary (Figure 3-38).

The 1985 and 1986 REMOTS® results confirmed that infaunal recolonization on the disposal mounds was proceeding within expected rates. Evidence of head-down deposit-feeding equilibrium assemblages were found at the older disposal mounds (NL-I, NL-II, NL-III, and NL-RELIC) as well as at the Reference station. The dominant infaunal taxon present in this area was ampeliscid amphipods (identified in the benthic community analyses as Ampelisca vadorum). Hydroids were evident in many photographs at the Reference station, apparently attached to the shells of small mussels. The results from the benthic infaunal analyses confirmed the presence of the juvenile mussel Musculus niger at this location in significant densities.

Recolonization at the NL-85 disposal mound also progressed at the expected rate. The pre-disposal survey in November 1985 documented the presence of Stage II and III organisms in high densities at this disposal location. During the post-disposal survey (January 1986), Stage I organisms were seen in the area of mapped dredged material with Stage II and III species elsewhere. In the survey conducted in July 1986, approximately six months after the major disposal operations had stopped, Stage II species (Ampelisca) were successfully recolonizing the disposal mound. Stage III organisms were seen at the flanks of the mound where they were able either to penetrate the thin layers of dredged material or to move over from ambient bottom. Comparison of the results of the benthic community analysis conducted in November 1985 and July 1986 confirmed the recolonization seen by REMOTS®. The overall species diversity at NL-85 was lower in July 1986 and dominated by Ampelisca (over 86% of individuals). Abundance of non-Ampelisca species was also significantly lower. In November 1985, the dominant taxa included many Stage III species (e.g., Nephtys, Tharyx, Tellina, and Nucula) while the dominant taxa in July 1986 included mostly Stage II species.

The NL-85 disposal mound station appeared to have been colonized by ampeliscid amphipods during the summer of 1986. Amphipods are known to be sensitive to sediment quality (hence their use as target species for many sediment bioassay tests). Dense assemblages of amphipods are commonly an intermediate (Stage II) sere in the normal infaunal successional sequence in Long Island Sound (Rhoads and Germano, 1982), and low species diversity is quite common in the early development of this assemblage. Due to the timing of the field investigations (several months after disposal had stopped), initial colonization of the dredged material mound by Stage I opportunistic polychaetes was not documented by the benthic sampling; this normally begins within 7-10 days after the initial disturbance (McCall, 1977; Germano, 1983). However, some dominants from this initial colonizing sere were still present (e.g., Prionospio steenstrupi). Previous work by other investigators (e.g., Woodin, 1976) has shown that settling larvae have an extremely difficult time establishing themselves among dense tube-dwelling assemblages. Given the early stage of

ecosystem recovery at the NL-85 mound, the low species richness in the ampeliscid assemblage is well within the expected sequence of recolonization events.

Visual and photo documentation determined that the conditions existing at the New London Disposal Site at the time of the diver surveys were typical for this site in the post-disposal phase. Areas containing dredged material consisted of compact cohesive sediments and all areas were densely colonized by amphipods. The thick mats of amphipod tubes reduced boundary layer flow velocities, thereby reducing erosion and often creating depositional environments. Surface features on and off of dredged material, except for crustacean "grotto" structures, made the two areas virtually indistinguishable.

The megafaunal assemblage observed was typical for this area at the time of the survey and all species observed exhibited typical behavior patterns. Bare patches in the amphipod tube carpet and shallow excavations were indications of active foraging behavior by the local fish and crustacean populations. Lobster burrows in the sediment and under debris were common in all locations surveyed. A portion of these burrows in each area were occupied by lobsters. Sediment burrows were often excavated into areas of slight topographic rise, allowing a more vertical burrow entrance.

The recolonization of the NL-85 disposal mound, as well as the other mounds, did not appear to be drastically hampered by any chemical stress related to the presence of the dredged material, despite the fact that concentrations of zinc, chromium, copper, and oil and grease in sediments at the disposal mounds were significantly elevated over those found in Reference station sediments (though still low relative to ranges of concentrations found throughout Long Island Sound). Because chemical concentrations were not found to be consistently higher or lower in the 0-2 cm sediment layer when compared to the 2-10 cm layer, neither shallow-feeding or deep-burrowing organisms should have been disproportionately stressed by the contaminants.

Comparison of results from previous sampling and analyses of sediment collected at the NL-I and NL-II mounds and at the Reference station indicates that chemical concentrations tended to be stable over time. At the Reference station, trace metal concentrations in sediment samples from 1982, 1984 (Morton et al., 1984), and 1986 are all very similar. Lead, cadmium, nickel, and mercury showed levels below the analytical detection limits in most of these samples. Similar results were found with the trace metal concentrations measured at the NL-I and NL-II stations. There did not appear to be any systematic temporal or spatial changes in the data collected over the four year period at these stations. Concentrations of organic compounds also appeared to unchanged over the same time period. The total hydrogen and total nitrogen levels

were below the detection limits in many samples while chemical oxygen demand, oil and grease, and total carbon results showed no consistent changes between the three sampling dates. PCBs were not analyzed in the samples collected in 1982 and 1984.

A comparison of sediment chemical concentrations from New London Disposal Site with existing data from other areas of Long Island Sound revealed that, in most cases, the range of concentrations were similar (Table 4-1). Munns et al. (in press) reported concentrations for sediment collected at the Reference station near the Central Long Island Sound Disposal Site. Benninger et al. (1979) measured concentrations of Pb, Zn, and Cu in sediments collected in central Long Island Sound. Grieg et al. (1977) measured the concentrations of several metals in surface sediments collected at stations in eastern Long Island Sound near the New London Disposal Site. Total carbon levels were measured in Block Island Sound by Boehm and Quinn (1978) and in Narragansett Bay by Wade and Quinn (1979) along with PCB's. At the disposal site, concentrations of all metals fell within the Class I (low) or lower Class II (moderate) categories set by the New England River Basins Commission (NERBC, 1980). The exception to this was one replicate sample for Zn at the NL-I mound, which was at the upper Class II level.

Although the exact effect of elevated sediment contaminant concentrations in the sediment on the benthic community is not known, chemical concentrations in the tissue of the bivalve Pitar were measured to determine the potential for biological uptake of contaminants from the sediment. Contaminant concentrations in Pitar from the disposal mound did not differ significantly from those at the Reference station. Similar levels of contaminants were found in samples collected and analyzed by other investigators (Table 4-2). Eisler et al. (1978) reported the concentrations of several metals from Pitar collected at control (i.e., "clean") stations in Narragansett Bay. Feng (1975) reported four trace metals in Pitar collected from an unspecified, but presumably clean, area of the Thames River. In all cases, the measured wet weight concentrations of trace metals in Pitar samples collected at the disposal mound station were well below the FDA Alert Levels (see Table 3-17). The PCB data were compared to concentrations in caged mussels Mytilus edulis maintained at the New London Disposal Site (Arimoto and Feng, 1983) and at the Reference station near the Central Long Island Sound Disposal Site (Munns et al., in press). All of the measured concentrations of PCBs were at least 50 times below the FDA Alert Level of 2 ppm.

The largest ecosystem stress affecting the New London Disposal Site apparently was not directly related to disposal activities but to a Sound-wide phenomenon of hypoxia in near-bottom waters. A low-oxygen, or hypoxic, event was inferred in July/August 1985 from low RPD values at REMOTS® stations along the northern boundary and in the southeast quadrant of the New London

Disposal Site. In Long Island Sound, this event is thought to be initiated by high water temperatures, a stratified water column, and high rates of organic loading related to sewage enrichment. Ampelisca amphipods seen swimming at the water surface also suggested low oxygen bottom waters. Evidence of reduced sediment conditions were still observed during the November 1985 survey. Amphipod tubes were seen in various stages of decay. Localized organic loading and/or water stratification may have contributed to this low oxygen stress on the bottom sediments. By the January 1986 survey, no evidence of near-bottom hypoxia was detected. This type of seasonal event has a significant influence on the infaunal successional status of the bottom. The fact that shallow RPD depths were observed in the REMOTS® photographs from late July and again in November does not necessarily mean that bottom oxygen values were low over the entire summer period. Bottom hypoxia in Long Island Sound usually develops over the period of July to early September. Once the water column is reventilated in September, it may take several weeks for infaunal benthos to pump aerated water back into the sediment and depress the RPD. The rate of RPD depression is approximately 0.2-0.3 mm per day (Germano and Rhoads, 1984).

5.0 CONCLUSIONS

The results from the bathymetric and REMOTS® surveys at the most recent disposal point (NL-85) and from the southwest reconnaissance grid demonstrated that management controls initiated by NED to insure containment of dredged material were largely successful. Most dredged material apparently was confined within a 600 meter radius of the disposal buoy, and no dredged material was detected at the southwest grid of stations located just outside the designated site boundaries. Relatively thin layers of dredged material were detected just outside the eastern site boundary in a very small area of minor concern (Figures 3-31 and 3-38). It is recommended in the future that the disposal point be located farther away from the boundary to avoid any dredged material occurring outside the site. Infaunal recolonization of the disposal mounds at the New London Disposal Site was proceeding well within the normal time course of successional events; the dominant taxon at the majority of stations sampled was the amphipod Ampelisca vadorum. Many of the older disposal mounds which had not been recently used for disposal had well-developed infaunal deposit-feeding communities. Areas within the southeastern quadrant of the site were obviously being affected by the Sound-wide phenomenon of seasonal hypoxia (the "August effect", sensu Rhoads and Germano, 1982); the stressed condition of the benthic communities in this affected area most likely was not due to the recent disposal activities.

Comparison of the results of trace metal analyses from the top 2 cm sections and 2-10 cm sections of sediment cores

collected at various locations within the site showed little, if any, statistically significant differences in contaminant concentrations. There was little supporting evidence at the disposal site to suspect either that a thin layer of contaminants was concentrated at the sediment surface due to resuspension and transport or, conversely, that surface sediment was cleaner than deeper layers due to desorption of contaminants, selective winnowing, or deposition of cleaner material.

An examination of temporal trends in trace metal concentrations from the Reference station and disposal mounds NL-I and NL-II over the past 4 years showed trace metal levels remained relatively stable at these stations. Similar results were found for the levels of organic compounds from these locations. Even though trace metal levels appeared temporally stable at these three locations, the levels of mercury, lead, zinc, arsenic, chromium, and copper were significantly elevated at several of the mounds compared with the Reference station; the levels of copper were consistently elevated at all sites tested. These levels were also higher than levels reported as background concentrations in eastern Long Island Sound; however, all concentrations fell within NERBC Class I (low) or lower Class II (moderate) categories. This is consistent with concentrations detected in the disposed material during pre-dredging testing. Nickel and cadmium levels were below analytical detection limits at each site. The NL-85, NL-I, and NL-RELIC stations showed somewhat elevated levels of total organic carbon; PCB concentrations of the NL-85 and NL-I sediments were at measurable, but low concentrations.

There were no significant differences in the concentrations of any of the eight metals tested in Pitar between the Reference and disposal mound stations. This information and comparisons of the trace metal data to literature values from relatively clean sites suggests that trace metals were not bioaccumulating in the bivalve Pitar morrhuana at the New London Disposal Site. The same was also true for PCBs. All of the PCB concentrations were below the analytical detection limits and well below FDA Alert Levels. These initial baseline data showed that there was minimal impact to resident suspension-feeding bivalves as a result of dredged material disposal at the New London Disposal Site.

6.0

REFERENCES

- Arimoto, R. and S. Feng. 1983. Changes in the levels of PCBs in Mytilus edulis associated with dredged-material disposal. In: D.R. Kester, B.H. Ketchum, I.W. Duedall and P.S. Park. (Eds). Wastes in the Ocean, Volume II: Dredged Material Disposal in the Ocean. New York: John Wiley and Sons, Inc. pp. 199-212.
- Benninger, L.S., R.C. Aller, J.K. Cochran and K.K. Turekian. 1979. Effects of biological sediment mixing on the ^{210}Pb chronology and trace metal distribution in a Long Island Sound sediment core. Earth and Planetary Science Letters 43:241-259.
- Boehm, P.D. and J.G. Quinn. 1978. Benthic hydrocarbons of Rhode Island Sound. Estuarine and Coastal Marine Science 6:471-494.
- Eisler, R., M.M. Barry, R.L. Lapan Jr., G. Telek, E.W. Davey and A.E. Soper. 1978. Metal survey of the marine clam Pitar morrhuana collected near a Rhode Island (USA) electroplating plant. Marine Biology 45:311-317.
- Feng, S.Y. 1975. An investigation on the effects of dredging in the Thames River on shellfish resources and phytoplankton. In: An Environmental Survey of Effects of Dredging and Spoil Disposal, New London, Connecticut. U.S. Department of Commerce Informal Report No. 84. pp. 1-115.
- Germano, J.D. 1983. Infaunal succession in Long Island Sound: Animal-sediment interactions and the effects of predation. Ph.D. dissertation. Yale University, New Haven, Connecticut.
- Germano, J.D. and D.C. Rhoads. 1984. REMOTS® sediment profiling at the Field Verification Program (FVP) disposal site. In: R.L. Montgomery and J.W. Leach (eds.). Dredging and Dredged Material Disposal. Volume 1. Am. Soc. Civil Engineers. New York, pp. 536-544.
- Greig, R.A., R.N. Reid and E.R. Wenzloff. 1977. Trace metal concentrations in sediments from Long Island Sound. Marine Pollution Bulletin 8:183-188.
- McCall, P.L. 1977. Community patterns and adaptive strategies of the infaunal benthos of Long Island Sound. J. Mar. Res. 35: 221-266.
- Morton, R.W., J.H. Parker and W.H. Richmond. 1984. DAMOS Disposal Monitoring System. Summary of Program Results 1981-1984. Volume III. Part B. SAIC Report #84/7521&C46. DAMOS Contribution #46, US Army Corps of Engineers, New England Division, Waltham, MA.

- Munns, W.R., Jr., J.F. Paul, V.J. Bierman, Jr., W.R. Davis, W.B. Galloway, G.L. Hoffman, R.R. Payne, P.F. Rogerson and R.J. Pruell. Exposure assessment component of the Field Verification Program: Data presentation and synthesis. U.S. Environmental Protection Agency, R.I. In press.
- New England River Basins Commission (NERBC). 1980. Interim Plan for the Disposal of Dredged Material from Long Island Sound. NERBC, Boston, MA. 55 p.
- Plumb, R.H. 1981. Procedures for handling and chemical analyses of sediment and water samples. Technical Report EPA/CE-81-1.
- Rhoads, D.C. 1974. Organism-sediment relations on the muddy sea floor. *Oceanogr. Mar. Bio. A. Rev.* 12: 263-300.
- Rhoads, D.C. and L.F. Boyer. 1982. The effects of marine benthos on physical properties of sediments: a successional perspective. In: P.L. McCall and M. Tevesz (eds.). *Animal-Sediment Relations*. Plenum Press, New York, pp. 3-51.
- Rhoads, D.C. and J.D. Germano. 1982. Characterization of benthic processes using sediment profile imaging: An efficient method of Remote Ecological Monitoring of the Seafloor (REMOTS® System). *Mar. Ecol. Prog. Ser.* 8: 115-128.
- Tavolaro, J.F. 1983. Sediment budget study for clamshell dredging and disposal activities. US Army Corps of Engineers, New York District. New York, NY.
- Wade, T.L. and J.G. Quinn. 1979. Geochemical distribution of hydrocarbons in sediments from mid-Narragansett Bay, Rhode Island. *Organic Geochemistry* 1: 157-167.
- Woodin, S.A. 1976. Adult-larval interactions in dense infaunal assemblages: Patterns of abundance. *J. Mar. Res.* 34: 24-41.

Table 2-1

Comparison of REMOTS® Grain-Size Major Mode Estimates with Conventional Sediment Analyses Rappahannock Disposal Sites-Chesapeake Bay

Numbers represent percent weight (%) in phi (ϕ) intervals.

Station 01			Station 02			Station 03		
ϕ	%	REMOTS®	ϕ	%	REMOTS®	ϕ	%	REMOTS®
-1-1	0.00		-1-1	0.00		-1-1	0.00	
1-2	0.00	$\geq 4\phi$	1-2	0.00	$\geq 4\phi$	1-2	0.00	$\geq 4\phi$
2-3	0.00		2-3	0.00		2-3	0.00	
3-4	0.00		3-4	0.00		3-4	0.00	
≥ 4	100.00		≥ 4	100.00		≥ 4	100.00	
Station 04			Station 05			Station 06		
ϕ	%	REMOTS®	ϕ	%	REMOTS®	ϕ	%	REMOTS®
-1-1	0.00		-1-1	0.00		-1-1	13.22	
1-2	0.00	$\geq 4\phi$	1-2	0.00	$\geq 4\phi$	1-2	83.05	1 - 2 ϕ
2-3	0.00		2-3	0.00		2-3	3.71	
3-4	0.00		3-4	0.00		3-4	0.00	
≥ 4	100.00		≥ 4	100.00		≥ 4	0.00	
Station 07			Station 08			Station 09		
ϕ	%	REMOTS®	ϕ	%	REMOTS®	ϕ	%	REMOTS®
-1-1	0.00		-1-1	0.00		-1-1	0.00	
1-2	4.04	$\geq 4\phi$	1-2	0.00	$\geq 4\phi$	1-2	0.00	$\geq 4\phi$
2-3	19.70		2-3	0.00		2-3	0.00	
3-4	4.96		3-4	0.00		3-4	0.00	
≥ 4	71.30		≥ 4	100.00		≥ 4	100.00	
Station 10			Station 11			Station 12		
ϕ	%	REMOTS®	ϕ	%	REMOTS®	ϕ	%	REMOTS®
-1-1	0.00		-1-1	0.00		-1-1	0.00	
1-2	0.00	$\geq 4\phi$	1-2	45.68	2 - 3 ϕ	1-2	74.70	1 - 2 ϕ
2-3	0.00		2-3	52.67		2-3	14.70	
3-4	8.31		3-4	1.65		3-4	0.00	
≥ 4	91.69		≥ 4			≥ 4	11.60	
Station 13			Station 14			Station 15		
ϕ	%	REMOTS®	ϕ	%	REMOTS®	ϕ	%	REMOTS®
-1-1	0.00		-1-1	0.00		-1-1	0.00	
1-2	0.00	$\geq 4\phi$	1-2	0.00	$\geq 4\phi$	1-2	0.00	$\geq 4\phi$
2-3	0.00		2-3	0.00		2-3	0.00	
3-4	0.00		3-4	0.00		3-4	0.00	
≥ 4	100.00		≥ 4	100.00		≥ 4	100.00	
Station 16			Station 17			Station 18		
ϕ	%	REMOTS®	ϕ	%	REMOTS®	ϕ	%	REMOTS®
-1-1	0.00		-1-1	0.00		-1-1	5.76	***
1-2	0.00	$\geq 4\phi$	1-2	0.00	$\geq 4\phi$	1-2	40.81	1 - 2 ϕ
2-3	0.00		2-3	0.00		2-3	42.00	
3-4	0.00		3-4	0.00		3-4	1.03	
≥ 4	100.00		≥ 4	100.00		≥ 4	10.40	

*** Stations where REMOTS® and conventional analyses disagree.

Table 2-1 continued.

Station 19			Station 20			Station 21		
ϕ	%	REMOTS [®]	ϕ	%	REMOTS [®]	ϕ	%	REMOTS [®]
-1-1	0.00	***	-1-1	0.00	***	-1-1	0.00	
1-2	69.16	2 - 3 ϕ	1-2	83.42	2 - 3 ϕ	1-2	68.17	1 - 2 ϕ
2-3	20.61		2-3	9.30		2-3	23.74	
3-4	0.00		3-4	0.00		3-4	0.00	
≥ 4	10.23		≥ 4	7.28		≥ 4	8.09	
Station 22			Station 23			Station 24		
ϕ	%	REMOTS [®]	ϕ	%	REMOTS [®]	ϕ	%	REMOTS [®]
-1-1	0.00		-1-1	0.00		-1-1	0.00	
1-2	0.00	$\geq 4\phi$	1-2	0.00	$\geq 4\phi$	1-2	0.00	$\geq 4\phi$
2-3	0.00		2-3	0.00		2-3	0.00	
3-4	0.00		3-4	0.00		3-4	0.00	
≥ 4	100.00		≥ 4	100.00		≥ 4	100.00	
Station 25			Station 26			Station 27		
ϕ	%	REMOTS [®]	ϕ	%	REMOTS [®]	ϕ	%	REMOTS [®]
-1-1	0.00	***	-1-1	0.58		-1-1	0.00	
1-2	47.55	2 - 3 ϕ	1-2	77.02	1 - 2 ϕ	1-2	6.05	$\geq 4\phi$
2-3	19.40		2-3	16.80		2-3	25.47	
3-4	4.23		3-4	0.00		3-4	5.42	
≥ 4	28.82		≥ 4	5.60		≥ 4	63.06	
Station 28			Station 29			Station 30		
ϕ	%	REMOTS [®]	ϕ	%	REMOTS [®]	ϕ	%	REMOTS [®]
-1-1	0.00		-1-1	0.00		-1-1	0.00	
1-2	47.83	1 - 2 ϕ	1-2	0.00	$\geq 4\phi$	1-2	0.00	$\geq 4\phi$
2-3	41.31		2-3	0.00		2-3	0.00	
3-4	0.33		3-4	0.00		3-4	0.00	
≥ 4	10.53		≥ 4	100.00		≥ 4	100.00	
Station 31			Station 32			Station 33		
ϕ	%	REMOTS [®]	ϕ	%	REMOTS [®]	ϕ	%	REMOTS [®]
-1-1	0.00		-1-1	0.00		-1-1	0.00	
1-2	0.00	$\geq 4\phi$	1-2	8.77	$\geq 4\phi$	1-2	0.00	$\geq 4\phi$
2-3	0.00		2-3	35.29		2-3	0.00	
3-4	0.00		3-4	5.10		3-4	4.68	
≥ 4	100.00		≥ 4	50.84		≥ 4	95.32	
Station 34			Station 35			Station 36		
ϕ	%	REMOTS [®]	ϕ	%	REMOTS [®]	ϕ	%	REMOTS [®]
-1-1	0.00		-1-1	0.00		-1-1	0.00	
1-2	0.23	$\geq 4\phi$	1-2	0.00	$\geq 4\phi$	1-2	0.00	$\geq 4\phi$
2-3	0.43		2-3	0.00		2-3	0.00	
3-4	28.04		3-4	0.00		3-4	0.00	
≥ 4	71.30		≥ 4	100.00		≥ 4	100.00	
Station 37			Station 38			Station 39		
ϕ	%	REMOTS [®]	ϕ	%	REMOTS [®]	ϕ	%	REMOTS [®]
-1-1	0.00		-1-1	0.00		-1-1	0.00	
1-2	0.00	$\geq 4\phi$	1-2	0.00	$\geq 4\phi$	1-2	0.00	$\geq 4\phi$
2-3	0.00		2-3	0.00		2-3	0.00	
3-4	4.73		3-4	18.21		3-4	11.35	
≥ 4	95.27		≥ 4	81.79		≥ 4	88.65	

*** Stations where REMOTS[®] and conventional analyses disagree.

Table 2-2

Calculation of the REMOTS®
Organism-Sediment Index (OSI) Value

CHOOSE ONE VALUE:

	<u>Mean RPD Depth</u>	<u>Index Value</u>
	0.00 cm	0
> 0	- 0.75 cm	1
0.76	- 1.50 cm	2
1.51	- 2.25 cm	3
2.26	- 3.00 cm	4
3.01	- 3.75 cm	5
>	3.75 cm	6

CHOOSE ONE VALUE:

<u>Successional Stage</u>	<u>Index Value</u>
Azoic	-4
Stage I	1
Stage I → II	2
Stage II	3
Stage II → III	4
Stage III	5
Stage I on III	5
Stage II on III	5

CHOOSE ONE OR BOTH IF APPROPRIATE:

<u>Chemical Parameters</u>	<u>Index Value</u>
Methane Present	-2
No/Low Dissolved Oxygen	-4

REMOTS® ORGANISM-SEDIMENT INDEX = Total of above
subset indices

RANGE: -10 to +11

Table 2-3

Instrument Operating Conditions and Detection Limits for Metals Analyzed
by Flame Atomic Absorption Spectrophotometry

<u>Element</u>	<u>Wave (nm)</u>	<u>Lamp Current (mA)</u>	<u>Slit Width (mm)</u>	<u>Gas Oxidant/ Fuel</u>	<u>Flame Type</u>	<u>Minimum Detection Limit (ppm)</u>	<u>Sensitivity (ppm/0.0044 Abs)</u>	<u>Additional Comments</u>
Cu	324.7	10	1.0	Air/C ₂ H ₂	Oxidizing	0.04	0.1	D ₂ correction
Zn	213.9	15	1.0	Air/C ₂ H ₂	Oxidizing	0.015	0.002	D ₂ correction

Table 2-4

Instrument Operating Conditions and Detection Limits for Metals Analyzed
by Graphite Furnace Atomic Absorption Spectrophotometry

<u>Element</u>	<u>Wave Length (nm)</u>	<u>Lamp Current (mA)</u>	<u>Slit Opening (mm)</u>	<u>Injection Volume (ul)</u>	<u>Gas</u>	<u>Furnace Conditions</u>
As	193.7	18	1.0	20	Ar (3 sec, normal flow, 20)	Dry: 110°C, 30 sec Char: 1200°C, 30 sec Atomize: 2700°C, 8 sec
Cd	228.8	4	1.0	10	Ar (3 sec, normal flow, 20)	Dry: 110°C, 22 sec Char: 350°, 22 sec Atomize: 2100°C, 7 sec
Cr	357.9	14	1.0	20	Ar (3 sec, normal flow, 30)	Dry: 110°C, 22 sec Char: 1100°, 22 sec Atomize: 2700°C, 7 sec
Hg	254	-	-	-	-	-
Pb	283.3	10	1.0	20	Ar (3 sec, normal flow, 20)	Dry: 110°C, 22 sec Char: 750°C, 22 sec Atomize: 2300°C, 7 sec

Table 2-4
(continued)

<u>Element</u>	<u>Minimum Detection Limit (ppb)</u>	<u>Absolute Detection Limit (picograms)</u>	<u>Sensitivity (ppb/ 0.0044 ABS)</u>	<u>Sensitivity (picograms/ 0.0044 ABS)</u>	<u>Additional Comments</u>
As	2	40	5	100	D ₂ correction
Cd	0.1	1	0.3	3	D ₂ correction
Cr	0.5	10	0.7	14	D ₂ correction
Hg	0.5	500	--	--	Cold vapor analysis
Pb	0.5	10	1	20	D ₂ correction

Table 2-5

Replicate Analysis of Pitar Samples and NRC Lobster
Hepatopancreas Tissue to Determine Analytical Precision

(Concentrations in ug/g dry weight)

Sample	As	Cd	Cr	Cu	Fe	Hg	Pb	Zn
<u>Pitar</u>	--	--	--	--	--	0.051	--	--
<u>Pitar</u>	--	--	--	--	--	0.060	--	--
Mean	--	--	--	--	--	0.055	--	--
RPD ¹	--	--	--	--	--	16.3	--	--
<u>Pitar</u>	12	0.97	0.69	16	240	--	4.8	150
<u>Pitar</u>	12	0.97	0.73	16	240	--	4.3	150
Mean	12	0.97	0.71	16	240	--	4.6	150
RPD	8	0	6	0	0	--	11	0
NRC Lobster -1	25.1	25.3	2.34	415	197	0.326	12.6	164
Tissue -2	27.6	25.8	2.18	406	191	0.301	9.85	164
-3	27.6	24.9	2.95	399	184	0.281	8.22	158
-4	26.6	26.2	2.21	412	188	0.29	10.0	159
Mean	26.7	25.6	2.42	408	190	0.300	10.2	161
Std. Dev.	1.18	0.57	0.36	7.1	5.5	0.02	1.8	3.2
RSD ²	4.4	2.2	15	1.7	2.9	6.5	18	1.9
Certified NRC ³ Values	24.6	26.3	2.4	439	186	0.330	10.4	177
Std. Dev.	2.2	2.1	0.6	22	11	0.06	2.0	10
% Recovery	108	97	100	93	102	91	98	91

¹ RPD = Relative Percent Deviation

² RSD = Relative Standard Deviation

³ Certified reference material distributed by the National Research Council of Canada

Table 2-6

**Summary of Diver Operations at the New London Disposal Site
July 1985**

<u>Location</u>	<u>Divers</u>	<u>Depth (ft)</u>	<u>LORAN-C Transects</u>	
			<u>Start</u>	<u>End</u>
SW Mussel Bed	Stewart	55	26130.0	26130.0
	Shepard		43977.4	43978.0
NW Sector	Auster	78	26140.4	26139.4
	Moreland		43976.1	43976.0
NL-I Mound	Stewart	52	26136.1	50m to west
	Shepard		43975.8	
NE Sector	Auster	57	26137.4	26139.0
	Moreland		44979.6	44979.4

Table 3-1

Results of Physical Analysis of Sediment Samples Collected at an Area Southwest of the New London Disposal Site, August 1985.

<u>Station</u>	<u>Classification</u>	<u>% Coarse Material</u>	<u>% Medium Sand</u>	<u>% Fine Sand</u>	<u>% Silt/ Clay</u>	<u>Specific Gravity</u>
C-13	Black organic sandy clayey silt w/ shell fragments (OH)	5	11	28	56	2.67
E-14	Black organic clayey silty medium to fine sand (SM)	<1	14	38	48	2.63
C-15	Light brown medium to fine sand w/ trace of silty shell fragments (SP)	<1	20	78	2	2.79
B-17	Light brown silty gravelly medium to fine sand w/ shell fragments	13	57	20	10	2.72
A-15	Same as C-15	1	27	64	5	2.76

Table 3-2

Results of Chemical Analysis of Sediment Samples Collected at an Area Southwest of the
New London Disposal Site, August 1985

(Concentrations in ppm)

Station	Hg	Pb	Zn	Fe	Cd	Cr	Cu	Ni	C:N	O&G
C-13-A	0.62	44	56	12,100	1.20	19	18	36	20.9	1,500
-B	0.03	24	62	12,800	0.33	20	19	36	14.4	1,000
-C	<u>0.08</u>	<u>28</u>	<u>67</u>	<u>15,100</u>	<u>0.79</u>	<u>24</u>	<u>21</u>	<u>32</u>	<u>20.4</u>	<u>1,280</u>
Mean	0.24	32	62	13,330	0.77	21	19	35	18.6	1,260
Std.Dev.	0.33	11	6	1,570	0.44	3	2	2	3.6	250
E-14-A	0.08	26	72	17,049	0.70	25	23	34	18.9	1,150
-B	0.07	32	91	19,690	<0.40	31	27	36	16.1	1,370
-C	<u>0.04</u>	<u>26</u>	<u>66</u>	<u>13,800</u>	<u>0.78</u>	<u>21</u>	<u>19</u>	<u>35</u>	<u>14.6</u>	<u>1,060</u>
Mean	0.06	28	76	16,850	--	26	23	35	16.5	1,190
Std.Dev.	0.02	3	13	2,950	--	5	4	1	2.2	160
C-15-A	0.04	11	17	6,250	1.60	5	5	8	NA*	544
-B	0.02	5	19	4,970	0.74	6	6	15	NA	70
-C	<u>0.16</u>	<u>19</u>	<u>22</u>	<u>4,880</u>	<u>0.80</u>	<u>6</u>	<u>7</u>	<u>25</u>	<u>NA</u>	<u>178</u>
Mean	0.07	12	19	5,370	1.05	6	6	16	--	264
Std.Dev.	0.08	7	3	770	0.48	1	1	9	--	248
B-17-A	0.22	26	23	5,050	1.20	6	7	29	NA	159
-B	0.22	16	24	2,840	1.60	5	7	29	80.4	101
-C	<u>0.20</u>	<u>40</u>	<u>36</u>	<u>7,940</u>	<u>3.60</u>	<u>9</u>	<u>10</u>	<u>21</u>	<u>NA</u>	<u>51</u>
Mean	0.21	27	28	5,280	2.13	7	8	26	--	104
Std.Dev.	0.01	12	7	2,560	1.29	2	2	5	--	54
A-15-A	0.14	10	14	7,120	0.79	4	4	5	NA	57
-B	0.20	11	16	5,760	1.40	4	5	7	NA	52
-C	<u>0.10</u>	<u>14</u>	<u>16</u>	<u>5,590</u>	<u>0.80</u>	<u>4</u>	<u>5</u>	<u>8</u>	<u>NA</u>	<u>75</u>
Mean	0.15	12	15	6,160	1.00	4	5	7	--	61
Std.Dev.	0.05	2	1	840	0.35	0	1	2	--	12

*NA = Not Available; %N was below detection limit of 0.1%.

Table 3-3

Results of Physical Analysis of Sediment Samples
Collected at the New London Disposal Site, July 1986.

<u>Station</u>	<u>Visual Description</u>	<u>% Coarse Material</u>	<u>% Med. Sand</u>	<u>% Fine Sand</u>	<u>% Silt/ Clay</u>	<u>Specific Gravity</u>
NL-I-Top	Dark olive gray organic silt (OH) w/ shell fragments	<1	3	10	90	--
	Dark olive gray silty sand (SM) w/ shell fragments	16	28	16	40	--
	Dark olive gray silty sand (SM)	26	32	21	21	--
NL-I-Bottom	Dark olive gray organic silt (OH)	<1	3	5	91	2.56
	Dark olive gray silty sand (SM) w/ shell fragments	18	20	19	43	--
	Dark olive gray organic silt (OH)	<1	5	8	86	--
NL-II-Top	Dark olive gray silty sand (SM) w/ shell fragments	2	4	53	41	--
	Dark olive gray silty sand (SM) w/ shell fragments	1	8	54	37	--
	Dark olive gray sandy organic silt (OH) w/ shell fragments	2	2	30	66	--
NL-II-Bottom	Dark olive gray silty sand (SM) w/ shell fragments	4	5	54	37	2.70
	Dark olive gray silty sand (SM)	2	4	49	45	2.75
	Dark olive gray organic silt (OH)	<1	1	7	92	2.72

Table 3-3 (Continued)

<u>Station</u>	<u>Visual Description</u>	<u>% Coarse Material</u>	<u>% Med. Sand</u>	<u>% Fine Sand</u>	<u>% Silt/ Clay</u>	<u>Specific Gravity</u>
NL-III-Top	Dark olive gray silty sand (SM)	13	29	43	15	--
	Dark olive gray silty sand (SM)	9	31	42	18	--
	Dark olive gray sandy organic silt (OH)	10	15	20	55	--
NL-III-Bottom	Dark olive gray silty sand (SM)	9	20	37	34	2.63
	Dark olive gray organic silt w/ sand (OH)	1	4	17	78	2.64
	Dark olive gray sandy organic silt (OH)	5	10	17	68	2.59
NL-RELIC-Top	Dark olive gray silty sand (SM)	20	22	34	24	--
	Dark olive gray sandy organic silt (OH)	8	4	18	70	--
	Dark olive gray silty sand (SM) w/ shell fragments	4	16	55	25	--
NL-RELIC-Bottom	Dark olive gray organic silt w/ sand (OH)	2	3	21	74	2.55
	Dark olive gray sandy organic silt (OH)	3	3	24	70	--
	Dark olive gray organic silt w/ sand (OH)	8	7	13	72	--

Table 3-3 (Continued)

<u>Station</u>	<u>Visual Description</u>	<u>% Coarse Material</u>	<u>% Med. Sand</u>	<u>% Fine Sand</u>	<u>% Silt/ Clay</u>	<u>Specific Gravity</u>
NL-85-Top	Dark olive gray organic silt (OH)	<1	2	7	90	--
	Dark olive gray organic silt (OH) w/ shell fragments	<1	1	13	85	--
	Dark olive gray organic silt (OH) w/ sand	4	4	12	80	--
NL-85-Bottom	Dark olive gray organic silt (OH)	<1	2	3	94	--
	Dark olive gray organic silt (OH)	<1	1	6	92	--
	Dark olive gray organic silt w/ sand (OH)	3	10	15	72	--
Reference-Top	Dark olive gray silty sand (SM) w/ shell fragments	1	13	69	17	--
	Dark olive gray silty sand (SM) w/ shell fragments	2	8	68	22	--
	Dark olive gray silty sand (SM) w/ shell fragments	5	13	69	13	--
Reference-Bottom	Dark olive gray silty sand (SM) w/ shell fragments	4	14	64	18	--
	Dark olive gray silty sand (SM) w/ shell fragments	4	14	62	20	2.73
	Dark olive gray silty sand (SM) w/ shell fragments	2	17	63	18	2.70

Table 3-4

Chemical Analysis of Sediment Collected at New London Disposal Site, July 1986
(Concentrations on a dry weight basis)

Replicate	<u>Reference</u>						<u>Mean (±Std.Dev)</u>	
	<u>A</u>		<u>B</u>		<u>C</u>		<u>Top</u>	<u>Bottom</u>
	<u>Top</u>	<u>Bottom</u>	<u>Top</u>	<u>Bottom</u>	<u>Top</u>	<u>Bottom</u>		
Hg ppm	<.05	<.05	<.05	<.05	<.05	<.05	---	---
Pb ppm	<25	<25	<25	<25	<25	<25	---	---
Zn ppm	31	34	28	34	76	60	45±27	43±15
As ppm	2.3	1.8	2.1	1.2	1.1	1.1	1.8±0.6	1.4±0.4
Cd ppm	<3	<3	<3	<3	<3	<3	---	---
Cr ppm	<9	9	9	11	10	10	---	10±1
Cu ppm	<5	7	7	8	6	<5	---	---
Ni ppm	<24	<24	<24	<24	<24	<24	---	---
Fe ppm	3290	4560	5610	6340	5560	5110	4820±1325	5336±911
% Tot. Carbon	0.54	0.83	1.55	0.64	0.52	1.32	0.87±0.59	0.93±0.35
% Tot. Hydrogen	0.10	0.15	0.16	0.11	<0.1	0.14	---	0.13±0.02
% Tot. Nitrogen	<0.1	<0.1	<0.1	<0.1	<0.1	<0.1	---	---
COD ppt ¹	18.8	46.5	46.0	25.1	35.7	36.7	33.5±13.7	36.1±10.7
Oil & Grease ppm	85.9	99.1	61.4	89.2	37.6	135	62±24	108±24
Total PCB ppm ²								<0.01

¹ Parts per thousand

² Single analysis of combined core sections

Note: Top = top 2 cm of core.

Bottom = remainder of core.

Table 3-4 continued.

NL-85

Replicate	A		B		C		Mean (Std.Dev.)	
	<u>Top</u>	<u>Bottom</u>	<u>Top</u>	<u>Bottom</u>	<u>Top</u>	<u>Bottom</u>	<u>Top</u>	<u>Bottom</u>
Hg ppm	.15	.11	.05	0.5	.29	.70	0.16±0.12	0.29±0.36
Pb ppm	126	121	97	111	31	<25	85±49	---
Zn ppm	202	187	201	204	88	83	164±66	191±11
As ppm	4.9	6.1	5.0	5.3	3.7	3.1	4.5±0.7	4.8±1.6
Cd ppm	<3	<3	<3	3	<3	<3	---	---
Cr ppm	67	68	58	65	24	23	50±23	52±25
Cu ppm	67	64	57	61	16	21	47±27	49±24
Ni ppm	25	<24	<24	26	<24	<24	---	---
Fe ppm	24100	22500	23200	26000	15800	14100	21033±4554	20867±6116
% Tot. Carbon	0.69	4.04	3.26	3.73	2.37	3.35	2.11±1.31	3.71±0.35
% Tot. Hydrogen	0.11	0.83	0.79	0.78	0.56	0.75	0.49±0.35	0.79±0.04
% Tot. Nitrogen	<0.1	0.33	0.27	0.31	0.22	0.31	---	0.32±0.01
COD ppt ¹	92.6	128	--	112	68.4	90.4	80.5±17.1	110±18.8
Oil & Grease ppm	558	1031	385	762	129	191	357±216	661±429
Total PCB ppm ²								0.21

¹ Parts per thousand

² Single analysis of combined core sections

Note: Top = Top 2cm of core.

Bottom = remainder of core.

Table 3-4 continued.

Replicate	<u>NL-I</u>						Mean (Std. Dev.)	
	A		B		C		Top	Bottom
	<u>Top</u>	<u>Bottom</u>	<u>Top</u>	<u>Bottom</u>	<u>Top</u>	<u>Bottom</u>	<u>Top</u>	<u>Bottom</u>
Hg ppm	.15	<.05	.22	.21	.14	.15	0.17±0.04	---
Pb ppm	<25	<25	82	105	118	38	---	---
Zn ppm	142	131	149	159	375	182	221±133	157±26
As ppm	3.8	3.7	2.7	3.9	2.1	2.5	2.9±0.9	3.4±0.8
Cd ppm	<3	<3	<3	<3	<3	<3	---	---
Cr ppm	34	36	20	22	16	32	23±9	30±7
Cu ppm	23	28	32	35	56	21	37±17	28±7
Ni ppm	<24	<24	<24	<24	33	<24	---	---
Fe ppm	25500	22700	11300	11000	11300	24300	16033±8198	19333±7261
% Tot. Carbon	2.38	3.43	4.63	4.99	2.40	2.90	3.14±1.29	3.77±1.07
% Tot. Hydrogen	0.61	0.82	0.56	0.72	0.36	0.73	0.51±0.13	0.76±0.06
% Tot. Nitrogen	0.19	0.26	0.24	0.22	0.12	0.21	0.18±0.06	0.23±0.03
COD ppt ¹	116	115	48.2	73.3	33.3	82.2	65.8±44.0	90.2±22.0
Oil & Grease ppm	91.7	199	302	428	150	128	181±108	252±157
Total PCB ppm ²								0.12

¹ Parts per thousand

² Single analysis of combined core sections

Note: Top = top 2 cm of core.

Bottom = remainder of core.

Table 3-4 continued.

Replicate	NL-II						Mean (Std. Dev.)	
	A		B		C		Top	Bottom
	Top	Bottom	Top	Bottom	Top	Bottom		
Hg ppm	.22	.40	.25	.33	.20	.12	0.22±0.03	0.28±0.15
Pb ppm	31	<25	27	<24	45	<25	34±9	---
Zn ppm	97	96	73	79	149	99	106±39	91±11
As ppm	1.6	1.3	1.9	2.0	4.5	3.4	2.7±1.6	2.2±1.1
Cd ppm	<3	<3	<3	3	<3	<3	---	---
Cr ppm	19	17	14	18	28	27	20±7	21±6
Cu ppm	14	12	16	11	23	17	18±5	13±3
Ni ppm	<24	<24	<24	<24	<24	<24	---	---
Fe ppm	11100	9850	6890	11500	16000	20700	11330±4559	14017±5846
% Tot. Carbon	1.22	0.97	0.76	0.79	1.80	1.16	1.26±0.52	0.97±0.19
% Tot. Hydrogen	0.27	0.22	0.17	0.23	0.40	0.40	0.28±0.12	0.28±0.10
% Tot. Nitrogen	<0.1	<0.1	<0.1	<0.1	0.17	0.11	---	---
COD ppt ¹	22.5	24.0	19.6	23.4	33.1	70.4	25.1±7.1	39.3±27.1
Oil & Grease ppm	153	113	129	95	174	102	152±23	103±9
Total PCB ppm ²								<0.01

¹ Parts per thousand

² Single analysis of combined core sections

Note: Top = top 2 cm of core.

Bottom = remainder of core.

Table 3-4 continued.

NL-III

Replicate	A		B		C		Mean (Std. Dev.)	
	<u>Top</u>	<u>Bottom</u>	<u>Top</u>	<u>Bottom</u>	<u>Top</u>	<u>Bottom</u>	<u>Top</u>	<u>Bottom</u>
Hg ppm	.31	<.05	.14	.06	.77	.17	0.41±0.33	---
Pb ppm	<25	37	<25	40	59	39	---	39±2
Zn ppm	190	109	94	147	125	96	136±49	117±27
As ppm	1.8	2.2	1.5	1.5	2.8	2.1	2.0±0.7	1.9±0.4
Cd ppm	<3	<3	<3	<3	<3	<3	---	---
Cr ppm	9	13	<9	16	50	35	---	21±12
Cu ppm	11	15	9	23	30	23	17±12	20±5
Ni ppm	<24	<24	<24	<24	<24	<24	---	---
Fe ppm	5180	7820	3800	9430	19400	17600	9460±8336	11617±5244
% Tot. Carbon	0.60	1.28	0.50	1.09	3.38	2.55	1.9±1.63	1.6±0.80
% Tot. Hydrogen	0.114	0.25	<0.1	0.24	0.57	0.55	---	0.35±0.18
% Tot. Nitrogen	<0.1	0.10	<0.1	<0.1	0.22	0.21	---	---
COD ppt ¹	19.9	38.5	39.9	62.1	116	190	58.6±50.7	96.9±81.5
Oil & Grease ppm	114	165	87	102	348	250	183±144	172±74
Total PCB ppm ²								<0.01

¹ Parts per thousand

² Single analysis of combined core sections

Note: Top = top 2 cm of core.

Bottom = remainder of core.

Table 3-4 continued.

Replicate	<u>NL-RELIC</u>						Mean (Std. Dev.)	
	A		B		C		Top	Bottom
	<u>Top</u>	<u>Bottom</u>	<u>Top</u>	<u>Bottom</u>	<u>Top</u>	<u>Bottom</u>	<u>Top</u>	<u>Bottom</u>
Hg ppm	.26	.67	.38	.84	.08	.35	0.24±0.15	0.62±0.25
Pb ppm	59	156	58	114	82	113	66±14	128±25
Zn ppm	139	173	154	174	185	189	159±23	179±9
As ppm	2.3	3.7	1.9	2.5	1.3	1.8	1.8±0.5	2.7±1.0
Cd ppm	<3	<3	<3	<3	<3	<3	---	---
Cr ppm	24	98	46	75	18	36	29±15	70±31
Cu ppm	29	89	35	50	22	37	29±7	57±24
Ni ppm	<23	<24	<24	<25	<22	<36	---	---
Fe ppm	8040	9900	18400	19200	10600	20400	12347±5396	19833±603
% Tot. Carbon	1.55	3.80	2.48	3.45	2.30	2.06	2.11±0.49	3.10±0.92
% Tot. Hydrogen	0.28	0.66	0.54	0.64	0.43	0.51	0.42±0.13	0.65±0.01
% Tot. Nitrogen	0.10	0.24	0.17	0.23	<0.1	0.17	---	0.21±0.04
COD ppt ¹	46.9	103	139	150	15.6	83.6	67.2±64.1	112±34
Oil & Grease ppm	480	1135	481	810	168	198	376±180	714±476
Total PCB ppm ²								0.03

¹ Parts per thousand

² Single analysis of combined core sections

Note: Top = top 2 cm of core.

Bottom = remainder of core.

Table 3-5

Results of Statistical Comparisons Between 0-2cm Core Sections
for the Five Disposal Mounds at the New London Disposal Site
and the Reference Station

	<u>NL-85</u>	<u>NL-I</u>	<u>NL-II</u>	<u>NL-III</u>	<u>NL-RELIC</u>
Mercury	ns ¹	* ²	*	*	*
Lead	*	ns	*	ns	*
Zinc	*	*	ns	*	*
Arsenic	*	ns	ns	ns	ns
Cadmium	- ³	-	-	-	-
Chromium	*	*	*	ns	*
Copper	*	*	*	*	*
Nickel	-	-	-	-	-
Tot. Carbon	ns	*	ns	ns	ns
COD ⁴	ns	ns	ns	ns	ns
Oil & Grease	*	*	*	*	*

¹ Not significantly different from Reference at $p < 0.05$, Mann Whitney U-test.

² Significantly greater ($p < 0.05$) than the Reference.

³ Values below detection limit

⁴ Chemical Oxygen Demand

Table 3-6

Results of Statistical Comparisons Between 2-10cm Core Sections
for the Five Disposal Mounds at the New London Disposal Site
and the Reference Station

	<u>NL-85</u>	<u>NL-I</u>	<u>NL-II</u>	<u>NL-III</u>	<u>NL-RELIC</u>
Mercury	ns ¹	ns	* ²	ns	*
Lead	ns	ns	ns	*	*
Zinc	*	*	*	*	*
Arsenic	*	*	ns	ns	ns
Cadmium	- ³	-	-	-	-
Chromium	*	*	*	*	*
Copper	*	*	*	*	*
Nickel	-	-	-	-	-
Tot. Carbon	*	*	ns	ns	*
COD ⁴	ns	*	ns	ns	*
Oil & Grease	*	ns	ns	ns	*

¹ Not significantly different from Reference at $p < 0.05$, Mann-Whitney U-test.

² Significantly greater ($p < 0.05$) than the Reference

³ Values below detection limit

⁴ Chemical Oxygen Demand

Table 3-7

Results of Statistical Comparisons Between 0-2cm Core Sections
and 2-10cm Core Sections for the Five Disposal Mounds
at the New London Disposal Site and the Reference Station

	<u>Reference</u>	<u>NL-85</u>	<u>NL-I</u>	<u>NL-II</u>	<u>NL-III</u>	<u>NL-RELIC</u>
Mercury	ns ¹	ns	ns	ns	ns	ns
Lead	ns	ns	ns	*-T ²	ns	*-B
Zinc	ns	ns	ns	ns	ns	ns
Arsenic	ns	ns	ns	ns	ns	ns
Cadmium	- ³	-	-	-	-	-
Chromium	ns	ns	ns	ns	ns	ns
Copper	ns	ns	ns	ns	ns	*-B
Nickel	-	-	-	-	-	-
Tot. Carbon	ns	*-B	ns	ns	ns	ns
COD ⁴	ns	ns	ns	ns	ns	ns
Oil & Grease	*-B	ns	ns	*-T	ns	ns

¹ Not significantly different at $p < 0.05$, Mann-Whitney U-test.

² Significantly different ($p < 0.05$); -T if 0-2cm > 2-10cm,
-B if 0-2cm < 2-10cm section.

³ Values below detection limit

⁴ Chemical Oxygen Demand

Table 3-8

Numerically Dominant Taxa In Order Of Abundance
At The New London Disposal Site, July 1985

Reference	NL-85
<u>Ampelisca vadorum</u>	<u>Ampelisca vadorum</u>
<u>Mediomastus ambiseta</u>	<u>Nucula annulata</u>
<u>Unciola irrorata</u>	<u>Mediomastus ambiseta</u>
Oligochaeta	<u>Unciola irrorata</u>
<u>Cerapus tubularis</u>	<u>Owenia fusiformis</u>
<u>Owenia fusiformis</u>	<u>Nephtys picta</u>
<u>Corophium bonelli</u>	<u>Tharyx annulosus</u>
<u>Tharyx annulosus</u>	<u>Turbonilla interrupta</u>
<u>Mitrella lunata</u>	<u>Polycirrus eximius</u>
<u>Tharyx acutus</u>	<u>Tellina agilis</u>

Table 3-9

Taxa Highly Associated with the NL-85 or Reference Station

<u>NL-85</u>	<u>Reference</u>
Anemones	<u>Nucula delphinodonta</u>
<u>Nucula annulata</u>	<u>Yoldia limatula</u>
<u>Cerastoderma pinnulatum</u>	<u>Anachis lafresnayi</u>
<u>Ensis directus</u>	<u>Mitrella lunata</u>
<u>Solemya velum</u>	<u>Aricidea jeffreysii</u>
<u>Turbonilla</u> sp.	<u>Exogene verugera</u>
<u>Nassarius trivittatus</u>	<u>Maldanid</u> juv.
<u>Asabellides oculata</u>	<u>Cyathura polita</u>
<u>Pista</u> sp.	<u>Edotea triloba</u>
<u>Polycirrus eximius</u>	<u>Cerapus tubularis</u>
<u>Microphthalmus sczelkowi</u>	<u>Corophium bonelli</u>
<u>Sabellaria vulgaris</u>	<u>Erichthonius</u> sp.
	Oligochaeta

Table 3-10

Benthic Community Analysis of Sediment Samples Collected
at New London Disposal Site, July 1985
(Counts per 0.1m² grab sample)

SPECIES	Reference			NL-85		
	1	2	3	1	2	3
RHYNCHOCOELA						
Lineidae						
<u>Micrura</u> sp.	1	4	1	2	2	2
Rhynchocoela S	3
PHORONIDA						
<u>Phoronis muelleri</u>	.	.	2	.	2	1
SIPUNCULA						
<u>Phascolion strombi</u>	1
ANNELIDA						
<u>Oligochaeta</u> spp.	184	55	58	5	.	.
Polychaeta						
Ampharetidae						
<u>Ampharete arctica</u>	3	3	.	3	.	1
<u>Asabellides oculata</u>	.	.	.	3	.	2
Arabellidae						
<u>Drilonereis longa</u>	.	1
Capitellidae						
<u>Mediomastus ambiseta</u>	319	187	229	174	123	545
<u>Notomastus latericius</u>	.	.	6	.	.	4
<u>Capitella capitata</u>	.	.	2	.	.	.
Chaetopteridae						
<u>Spiochaetopterus oculatus</u>	3	.	2	2	.	.
Cirratulidae						
<u>Chaetozone setosa</u>	31	21	14	12	2	1
<u>Cossura longocirrata</u>	2
<u>Tharyx acutus</u>	.	.	.	2	.	.
<u>Tharyx B</u>	45	28	32	27	12	46
Dorvilleidae						
Dorvilleid sp.	.	.	.	2	.	.
Flabelligeridae						
<u>Pherusa affinis</u>	1	1	2	1	.	1
Glyceridae						
<u>Glycera americana</u>	6	3	6	10	3	13

Table 3-10 (Continued)

SPECIES	Reference			NL-85		
	<u>1</u>	<u>2</u>	<u>3</u>	<u>1</u>	<u>2</u>	<u>3</u>
Hesionidae						
<u>Microphthalmus</u> <u>szcelkowii</u>	.	.	.	18	5	13
Lumbrineridae						
<u>Lumbrinereis</u> <u>tenuis</u>	2	.	3	1	.	3
<u>Ninoe</u> <u>nigripes</u>	7	2	6	13	8	17
Maldanidae						
<u>Asychis</u> <u>elongata</u>	.	3	.	.	1	5
<u>Clymenella</u> <u>torquata</u>	1	.
<u>Clymenella</u> <u>zonalis</u>	4	.	2	2	.	.
Maldanid sp.	4	8	6	.	.	.
Nephtyidae						
<u>Nephtys</u> <u>incisa</u>	.	.	2	2	1	1
<u>Nephtys</u> <u>picta</u>	24	14	21	25	8	51
Onuphidae						
<u>Diopatra</u> <u>cuprea</u>	1
Orbiniidae						
<u>Scoloplos</u> <u>acutus</u>	.	1
Oweniidae						
<u>Owenia</u> <u>fusiformis</u>	54	45	52	26	34	101
Paraonidae						
<u>Aricidea</u> <u>jeffreysii</u>	18	2	9	.	.	.
<u>Paraonis</u> <u>gracilis</u>	.	.	.	4	.	2
Phyllodocidae						
<u>Paranaitis</u> <u>speciosa</u>	.	.	5	6	.	3
<u>Phyllodoce</u> <u>arenae</u>	10	8	7	8	1	18
Polynoidae						
<u>Harmothoe</u> <u>extenuata</u>	1	.	.	1	.	.
<u>Lepidonotus</u> <u>sublevis</u>	.	.	.	1	.	.
Sabellaridae						
<u>Sabellaria</u> <u>vulgaris</u>	.	.	.	6	.	2
Scalibregmidae						
<u>Scalibregma</u> <u>inflatum</u>	.	1
Sigalionidae						
<u>Pholoe</u> <u>minuta</u>	8	2	6	8	9	26

Table 3-10 (Continued)

SPECIES	Reference			NL-85		
	<u>1</u>	<u>2</u>	<u>3</u>	<u>1</u>	<u>2</u>	<u>3</u>
Sphaerodoridae						
<u>Ephesiella minuta</u>	.	.	.	1	.	.
Spionidae						
<u>Polydora caulleryi</u>	.	.	.	1	.	.
<u>Polydora socialis</u>	.	.	.	1	.	.
<u>Spio filicornis</u>	.	.	1	.	1	6
<u>Spiophanes bombyx</u>	3	.	.	9	.	.
Syllidae						
<u>Syllid sp.</u>	.	4
Terebellidae						
<u>Pista cristata</u>	.	.	.	1	.	.
<u>Pista maculata</u>	1
<u>Polycirrus eximius</u>	.	.	.	8	14	33
MOLLUSCA						
Bivalvia						
Arcidae						
<u>Anadara transversa</u>	.	1	.	.	.	1
Astartidae						
<u>Astarte undata</u>	6	5	6	2	3	7
Cardiidae						
<u>Cerastoderma pinnatulum</u>	.	.	.	1	2	7
Carditidae						
<u>Cyclocardia borealis</u>	.	5	3	.	3	2
Lyonsiidae						
<u>Lyonsia hyalina</u>	16	6	9	8	5	9
Montocutidae						
<u>Mysella sp.</u>	1	.	2	1	.	.
Mytilidae						
mytillid spat	.	2	2	.	.	.
Nuculanidae						
<u>Yoldia limatula</u>	1	1	2	.	.	.
Nuculidae						
<u>Nucula annulata</u>	4	2	10	152	181	658
<u>Nucula delphinodonta</u>	6	16	6	.	.	.
Pandoridae						
<u>Pandora gouldiana</u>	1	1	.	2	.	2

Table 3-10 (Continued)

SPECIES	Reference			NL-85		
	<u>1</u>	<u>2</u>	<u>3</u>	<u>1</u>	<u>2</u>	<u>3</u>
Periplomatidae						
<u>Periploma papyratium</u>	6
Petricolidae						
<u>Petricola pholadiformis</u>	.	.	.	1	.	.
Solemyacidae						
<u>Solemya velum</u>	1	.	.	2	.	.
Solenidae						
<u>Ensis directus</u>	.	.	.	1	1	1
Tellinidae						
<u>Tellina agilis</u>	40	52	21	18	1	25
Veneridae						
<u>Mercenaria mercenaria</u>	1
<u>Pitar morrhuana</u>	5	3	2	5	6	9
Bivalvia spp.	.	2	.	1	2	3
Gastropoda						
Acteonidae						
<u>Acteon punctostriatus</u>	4
Calyptraeidae						
<u>Crepidula sp.</u>	6	1	2	4	2	.
Columbellidae						
<u>Anachis lafresnayi</u>	1	2	2	.	.	.
<u>Mitrella lunata</u>	32	27	40	1	.	.
Hydrobiidae						
<u>Hydrobia sp..</u>	1
Muricidae						
<u>Urosalpinx cinereus</u>	.	.	.	1	.	4
Nassariidae						
<u>Nassarius trivittatus</u>	1	2	1	4	18	25
Naticidae						
<u>Lunatia triseriata</u>	.	.	1	.	.	.
Pyramidellidae						
<u>Turbonilla intrrupta</u>	7	6	.	8	10	39

Table 3-10 (Continued)

SPECIES	Reference			NL-85		
	1	2	3	1	2	3
ARTHROPODA						
Crustacea						
Amphipoda						
Gammaridea						
Ampeliscidae						
<u>Ampelisca vadorum</u>	10231	7692	9940	1017	195	1655
<u>Ampelisca macrocephala</u>	.	.	.	4	3	.
<u>Byblis serrata</u>	.	.	.	1	.	3
Aoridae						
<u>Microdentopus anomalus</u>	1
Corophiidae						
<u>Corophium bonelli</u>	25	61	36	1	.	.
<u>Cerapus tubularius</u>	127	67	92	2	7	72
<u>Erichthonius sp.</u>	8	8	17	.	.	1
<u>Unciola irrorata</u>	119	146	147	76	35	185
Gammaridae						
<u>Gammarus sp.</u>	1
Lilljeborgiidae						
<u>Listriella barnardi</u>	.	.	1	.	.	.
Lysianassidae						
<u>Lysianopsis alba</u>	1
<u>Orchomonella pinguis</u>	1
Photidae						
<u>Leptocheirus pinguis</u>	6	1	1	1	.	3
<u>Microprotopus shoemakeri</u>	.	.	1	.	.	.
<u>Photis reinhardi</u>	.	.	2	.	.	1
Photid sp.	.	.	1	.	.	2
Phoxocephalidae						
<u>Phoxocephalus holbolli</u>	.	.	1	.	.	.
Retusidae						
<u>Retusa canaliculata</u>	1	.	1	1	1	4
Stenothoidae						
<u>Parametopella cypris</u>	.	.	2	.	.	.
Caprellidea						
<u>Caprella sp.</u>	.	.	.	1	.	.

Table 3-10 (Continued)

SPECIES	Reference			NL-85		
	1	2	3	1	2	3
Cumacea						
Diastylidae						
<u>Diastylis polita</u>	2
<u>Diastylis sculpta</u>	.	.	.	6	.	2
Leuconidae						
<u>Eudorella trucatula</u>	.	2
Isopoda						
Anthuridae						
<u>Cyathura polita</u>	.	4	2	.	.	.
Idoteidae						
<u>Edotea triloba</u>	17	13	.	3	.	4
Decapoda						
Caridea						
Crangonidae						
<u>Crangon septemspinosus</u>	.	.	3	.	.	1
Paguridae						
<u>Pagurus longicarpus</u>	.	1	4	6	7	9
Brachyura						
Canceridae						
<u>Cancer irroratus</u>	.	.	.	2	.	.
Pinnotheridae						
<u>Pinnixa</u> sp.	.	1	1	.	.	1
Echinodermata						
Holothuroidea						
<u>Caudina arenata</u>	.	.	1	1	.	.
Ophiuroidea						
Ophiuroid sp.	2

Table 3-11

Summary of Totals, and Distribution of Individuals
Among Major Phyla at New London Disposal Site, July 1985

Replicate #	<u>Reference</u>			<u>NL-85</u>		
	1	2	3	1	2	3
Species/sample	52	50	56	65	36	64
Species/station		81			85	
Total species			112			
<u>Ampelisca</u> /sample	10231	7692	9940	1017	195	1655
mean <u>Ampelisca</u> /station		9288			956	
non- <u>Ampelisca</u> /sample	1183	534	931	707	517	1997
mean non- <u>Ampelisca</u> /station		883			1074	
% <u>Ampelisca</u> /station		91%			47%	

Number of Species in Major Taxa

	<u>Reference</u>	<u>NL-85</u>	<u>Total</u>
Polychaeta	30	38	46
Gastropoda	7	8	10
Bivalvia	16	13	18
Amphipoda	15	12	19
Other	<u>13</u>	<u>14</u>	<u>19</u>
	81	85	112

Table 3-12

**Visual Descriptions of Biological Sediment Samples
Collected at New London, July 1986**

<u>Station</u>	<u>Description</u>
NL-85-1	Light gray cohesive silt with <u>Ampelisca</u> worm tubes and H ₂ S odor
NL-85-2	2 cm dark gray layer of gelatinous sandy silt over dryer cohesive sandy silt, no biota
NL-85-3	Same as NL-85-1
NL-85-4	Similar to NL-85-3 with very thin oxidized layer (0.5 cm) and some worm tubes
NL-85-5	Similar to NL-85-4 with more worm tubes
Reference-1	Sandy surface with shells and hydroids over 4-5 cm of silty sand
Reference-2	Same as above with molluscs, hermit crabs and worm tubes
Reference-3	Same as Reference-2
Reference-4	Same as Reference-2
Reference-5	Same as Reference-2

Table 3-13

Benthic Community Analysis of Sediment Samples Collected
at New London Disposal Site, July 1986
(Counts per 0.1m² grab sample)

SPECIES	Reference			NL-85		
	1	2	3	1	2	4
PLATYHELMENTHES sp.	.	1
RHYNCHOCOELA						
Lineidae						
<u>Micrura</u> sp.	.	2	.	4	4	.
Tubulanidae						
<u>Tubulanus pellucidus</u>	1
Rhychocoela P	1
Rhychocoela TE	.	1
Rhychocoela S	2	6	3	2	.	1
PHORONIDA						
<u>Phoronis muelleri</u>	.	8	2	.	.	1
SIPUNCULA						
<u>Golfingia margaritacea</u>	.	.	1	.	.	.
ANNELIDA						
<u>Oligochaeta</u> spp.	87	50	73	1	3	1
Polychaeta						
Ampharetidae						
<u>Ampharete arctica</u>	43	44	37	.	.	.
<u>Asabellides oculata</u>	5	3	3	4	.	.
Arabellidae						
<u>Drilonereis longa</u>	1	1
Capitellidae						
<u>Mediomastus ambiseta</u>	152	17	157	1	.	.
<u>Notomastus latericius</u>	3	.	4	.	.	.
Chaetopteridae						
<u>Spiochaetopterus oculatus</u>	.	1	1	.	.	.
Cirratulidae						
<u>Tharyx NR acutus</u>	54	14	40	4	.	.
<u>Tharyx NR annulosus</u>	179	71	170	.	.	.
<u>Tharyx marioni</u>	.	.	2	.	.	.
Dorvilleidae						
<u>Protodorvillea kefersteini</u>	10	2	12	.	.	.

Table 3-13 (Continued)

SPECIES	Reference			NL-85		
	1	2	3	1	2	4
Eunicidae						
<u>Marphysa belli</u>	.	.	2	.	.	.
Flabelligeridae						
<u>Pherusa affinis</u>	.	5	3	.	.	.
Glyceridae						
<u>Glycera americana</u>	3	1	5	.	.	.
Lumbrineridae						
<u>Lumbrineris tenuis</u>	5	3	16	.	1	.
<u>Ninoe nigripes</u>	6	6	9	6	.	.
Maldanidae						
<u>Asychis elongata</u>	2	5	6	1	.	.
<u>Clymenella torquata</u>	22	9	12	.	.	.
<u>Clymenella zonalis</u>	78	15	38	.	.	.
Nephtyidae						
<u>Aglaophamus circinata</u>	2
<u>Nephtys incisa</u>	2	.	8	.	.	2
<u>Nephtys picta</u>	10	26	7	1	.	.
Opheliidae						
<u>Ammotrypane aulogaster</u>	9	11	8	.	.	.
Oweniidae						
<u>Owenia fusiformis</u>	6	3
Paraonidae						
<u>Aricidea jeffreysii</u>	22	60	16	.	.	.
<u>Paraonis gracilis</u>	6	.	1	.	.	.
Phyllodoceidae						
<u>Eulalia bilineata</u>	11	8	8	1	.	.
<u>Eteone longa</u>	1
<u>Paranaitis speciosa</u>	2
<u>Phyllococe arenae</u>	2	5	1	.	.	.
<u>Phyllococe maculata</u>	1	4	1	1	.	.
<u>Phyllococe sp. juv.</u>	9	.	13	5	2	1
Polynoidae						
<u>Harmothoe extenuata</u>	44	29	37	.	.	.
Sabellaridae						
<u>Sabellaria vulgaris</u>	2	.	1	.	.	.

Table 3-13 (Continued)

SPECIES	Reference			NL-85		
	1	2	3	1	2	4
Sabellidae						
<u>Chone infundibuliformis</u> juv.	.	3	13	.	.	.
<u>Euchone rubrocincta</u>	.	.	3	.	.	.
<u>Potamilla reniformis</u>	1	2
Scalibregmidae						
<u>Scalibregma inflatum</u>	7	8	5	.	.	.
Sigalionidae						
<u>Pholoe minuta</u>	17	18	22	1	1	2
<u>Sthenelais boa</u>	1
Spionidae						
<u>Polydora caulleryi</u>	18	12	5	1	.	.
<u>Polydora ligni</u>	.	1	.	1	.	3
<u>Polydora quadrilobata</u>	1	1
<u>Polydora socialis</u>	10	17	4	.	.	1
<u>Spio filicornis</u>	.	3
<u>Spio pettiboneae</u>	1	2
<u>Spiophanes bombyx</u>	5	11	.	1	.	1
<u>Prionospio steenstrupi</u>	145	133	154	8	47	107
Syllidae						
<u>Autloytus prolifer</u>	3	5	3	.	.	.
<u>Exogone dispar</u>	2	.	1	.	.	.
<u>Syllis gracilis</u>	.	.	2	.	.	.
<u>Syllid</u> sp.	1	1	1	.	.	.
Terebellidae						
<u>Amphitrite johnstoni</u>	1	2
<u>Polycirrus eximius</u>	29	24	17	.	.	.
<u>Terebellid</u> sp.	.	.	1	.	.	.
MOLLUSCA						
Bivalvia						
Arcidae						
<u>Anadara transversa</u>	1	1	3	.	.	.
Astartidae						
<u>Astarte undata</u>	1	7	11	.	.	.
Cardiidae						
<u>Cerastiderma pinnatulum</u>	22	20	14	4	1	1
Carditidae						
<u>Cyclocardia borealis</u>	.	3	10	.	.	.
Hiatellidea						
<u>Hiatella arctica</u>	1

Table 3-13 (Continued)

SPECIES	Reference			NL-85		
	1	2	3	1	2	4
Lyonsiidae						
<u>Lyonsia hyalina</u>	5	1	6	.	.	.
Mactridae						
<u>Mulinia lateralis</u>	1
Montocutidae						
<u>Mysella planulata</u>	1	1
Mytilidae						
<u>Crenella decussata</u>	2	2	2	.	.	.
<u>Musculus niger</u> juv.	117	277	125	.	.	.
Nuculanidae						
<u>Yoldia limatula</u>	1
Nuculidae						
<u>Nucula annulata</u>	4	4	1	1	.	.
<u>Nucula delphinodonta</u>	.	11	17	.	.	.
Pandoridae						
<u>Pandora gouldiana</u>	1	4	4	.	.	.
Petricolidae						
<u>Petricola pholadiformis</u>	1	.	1	2	.	.
Solenidae						
<u>Ensis directus</u>	.	2	.	1	.	.
Tellinidae						
<u>Tellina agilis</u>	7	5	2	.	.	.
Veneridae						
<u>Pitar morrhuana</u>	6	16	37	.	.	.
Bivalvia spp.	2
Gastropoda						
Actenidae						
<u>Acteon punctostriatus</u>	1
Calyptraeidae						
<u>Crepidula fornicata</u>	1	.	1	.	.	.
<u>Crepidula plana</u>	2
Columbellidae						
<u>Anachis lafresnayi</u>	5	1	2	.	.	.
<u>Mitrella lunata</u>	8	4	2	.	.	1

Table 3-13 (Continued)

SPECIES	Reference			NL-85		
	<u>1</u>	<u>2</u>	<u>3</u>	<u>1</u>	<u>2</u>	<u>4</u>
Muricidae						
<u>Urosalpinx cinereus</u>	1
Nassariidae						
<u>Nassarius trivittatus</u>	1	4
Naticidae						
<u>Lunatia triseriata</u>	2	4	7	.	.	.
Pyramidellidae						
<u>Turbonilla intrrupta</u>	12	30	11	.	.	.
<u>Odostomia A</u>	.	8	3	.	.	.
Skeneopsidae						
<u>Skeneopsis planorbis</u>	21
Gastropoda R	3	4	3	.	.	.
ARTHROPODA						
Crustacea						
Amphipoda						
Gammaridea						
Ampeliscidae						
<u>Ampelisca vadorum</u>	301	1090	1040	618	353	1423
<u>Ampelisca verrilli</u>	.	3
Calliopidae						
<u>Calliopus laeviusculus</u>	.	.	1	.	.	.
Corophiidae						
<u>Corophium acutum</u>	1	4	.	.	1	.
<u>Corophium bonelli</u>	15	15	19	.	.	.
<u>Cerapus tubularius</u>	.	.	2	.	.	.
<u>Erichthonius brasiliensis</u>	2	.	3	.	.	.
<u>Unciola irrorata</u>	23	47	35	30	12	75
Lysianassidae						
<u>Orchomenella minuta</u>	1	.
Photidae						
<u>Leptocheirus pinguis</u>	23	75	145	14	.	12
<u>Photis reinhardi</u>	.	.	.	3	.	.
Phoxocephalidae						
<u>Paraphoxus spinosus</u>	1	1
<u>Trichophoxus epistomus</u>	.	1
<u>Phoxocephalus holbolli</u>	22	4	10	.	.	.

Table 3-13 (Continued)

SPECIES	Reference			NL-85		
	1	2	3	1	2	4
Pleustidae						
<u>Stenopeustes gracilis</u>	16	13	6	.	1	.
Podoceridae						
<u>Dyopedos monocantha</u>	2	.	1	.	.	1
Stenothoidae						
<u>Parametopella cypris</u>	.	.	2	.	.	1
Caprellidea						
<u>Caprella equilibra</u>	17	5	6	.	.	.
Cumacea						
Diastylidae						
<u>Diastylis quadrispinosa</u>	.	1	2	.	.	.
Leuconidae						
<u>Eudorella trucatula</u>	1
Isopoda						
Anthuridae						
<u>Ptilanthura tricarina</u>	1	4	5	.	.	.
Idoteidae						
<u>Edotea triloba</u>	1	4	4	.	.	.
Decapoda						
Caridea						
Crangonidae						
<u>Crangon septemspinosa</u>	4	1
Anomura						
Axiidae						
<u>Axius serratus</u>	2
Paguridae						
<u>Pagurus longicarpus</u>	4	3
Brachyura						
Majidae						
<u>Libinia dubia</u>	.	1
Canceridae						
<u>Cancer irroratus</u>	10	12	5	.	.	4
Pinnotheridae						
<u>Pinnixa</u> sp.	1

Table 3-13 (Continued)

SPECIES	Reference			NL-85		
	<u>1</u>	<u>2</u>	<u>3</u>	<u>1</u>	<u>2</u>	<u>4</u>
Echinodermata						
<u>Amphipholis squamata</u>	6	4	5	.	.	.
Asteroidea juv.	.	.	1	2	.	5
Hemichordata						
<u>Saccoglossus kowalevskii</u>	1

Table 3-14

Summary of Totals, and Distribution of Individuals
Among Major Phyla at New London Disposal Site, July 1986

Replicate #	<u>Reference</u>			<u>NL-85</u>		
	1	2	3	1	2	4
Species/sample	93	84	82	26	12	23
Species/station		120			41	
Total species			125			
<u>Ampelisca</u> /sample	301	1093	1040	618	353	1423
mean <u>Ampelisca</u> /station		811			798	
non- <u>Ampelisca</u> /sample	1405	1257	1442	100	74	224
mean non- <u>Ampelisca</u> /station		1368			133	
% <u>Ampelisca</u> /station		37%			86%	

Number of Species in Major Taxa

	<u>Reference</u>	<u>NL-85</u>	<u>Total</u>
Polychaeta	53	18	53
Gastropoda	12	1	12
Bivalvia	18	6	19
Amphipoda	18	9	20
Other	<u>19</u>	<u>7</u>	<u>21</u>
	120	41	125

Table 3-15

Numerically Dominant Taxa in Order of Abundance
at the New London Disposal Site, July 1986

Reference	NL-85
<u>Ampelisca vadorum</u>	<u>Ampelisca vadorum</u>
<u>Musculus niger</u> juv.	<u>Prionospio steenstrupi</u>
<u>Tharyx annulosus</u>	<u>Unciola irrorata</u>
<u>Prionospio steenstrupi</u>	<u>Leptocheirus pinguis</u>
<u>Mediomastus ambiseta</u>	
<u>Leptocheirus pinguis</u>	
Oligochaeta	
<u>Clymenella zonalis</u>	
<u>Ampharete arctica</u>	
<u>Harmothoe extenuata</u>	
<u>Tharyx acutus</u>	
<u>Unciola irrorata</u>	
<u>Aricidea jeffreysii</u>	

Table 3-16

Trace Metals (Dry Weight) in Body Tissues of Pitar Collected
at New London, July 1986

<u>Station</u>	Concentration in ug/g dry weight								
	<u>As</u>	<u>Cd</u>	<u>Cr</u>	<u>Cu</u>	<u>Fe</u>	<u>Hg</u>	<u>Pb</u>	<u>Zn</u>	
Reference 1	14	1.70	0.85	15	300	0.073	6.5	130	
Reference 2	14	1.10	0.36	13	160	0.077	3.7	140	
Reference 3	12	1.10	0.48	14	200	0.067	2.3	140	
Mean	13	1.3	0.56	14	220	0.072	4.2	136	
±Std. Dev.	1	0.3	0.26	1	72	0.005	2.1	6	
NL-I Mound 1	10	0.69	0.54	16	190	0.021	2.7	130	
NL-I Mound 2*	12	0.97	0.71	16	240	0.089	4.5	150	
NL-I Mound 3 ⁺	8	1.30	0.64	16	370	0.055	10.7	200	
Mean	10	0.99	0.63	16	267	0.055	6.0	160	
±Std. Dev.	2	0.31	0.09	0	93	0.034	4.2	36	

* Values are average of two reps for all elements except Hg.

+ Hg value is an average of two reps.

Table 3-17

Trace Metals (Wet Weight) in Body Tissues of Pitar Collected
at New London, July 1986

<u>Station</u>	Concentration in ug/g wet weight							
	<u>As</u>	<u>Cd</u>	<u>Cr</u>	<u>Cu</u>	<u>Fe</u>	<u>Hg</u>	<u>Pb</u>	<u>Zn</u>
Reference 1	1.3	0.16	0.078	1.38	28	0.0067	0.60	12
Reference 2	1.3	0.10	0.033	1.21	15	0.0072	0.34	13
Reference 3	1.0	0.09	0.040	1.18	17	0.0056	0.19	12
Mean	1.2	0.12	0.050	1.26	20	0.0065	0.38	12
±Std. Dev.	0.2	0.04	0.024	0.11	7	0.0008	0.21	1
NL-I Mound 1	1.1	0.07	0.058	1.70	20	0.0022	0.29	14
NL-I Mound 2*	1.3	0.11	0.078	1.80	26	0.0098	0.50	17
NL-I Mound 3 ⁺	0.7	0.11	0.056	1.40	33	0.0048	0.94	18
Mean	1.0	0.10	0.064	1.63	26	0.0056	0.58	16
±Std. Dev.	0.3	0.02	0.012	0.21	7	0.0039	0.33	2
FDA Alert Levels	--	0.5	1.0	10	--	0.2	4.0	65

* Values are average of two reps for all elements except Hg.

+ Hg value is an average of two reps.

Table 3-18

**PCB's in Body Tissues of the Bivalve Pitar morrhuana
Collected at the New London Disposal Site, July 1986**

(Concentrations as Aroclor 1254¹ in ng/g)

<u>Reference</u>	<u>Disposal Mound</u>
------------------	-----------------------

Dry Weight Basis

<160 ²	<250
<170	<260
<280	< 97

Wet Weight Basis

< 15	< 27
< 16	< 29
< 23	< 9

¹ See Section 2.0 for the relationship of Aroclor 1254 to other PCB mixtures.

² All values were below the stated detection limit.

Table 3-19

Abundances of Megafauna Observed During Survey Dives
at the New London Disposal Site, July 1986

Species	NL-I <u>Mound</u>	NW <u>Sector</u>	NE <u>Sector</u>	SW <u>Mussel Bed</u>
Polychaete				
<u>Diopatra cuprea</u>				6
Gastropoda				
<u>Busycon</u> sp.				6
<u>Nassarius trivittatus</u>		>10/0.25m ²		
Crustacea				
<u>Libinia emarginata</u>				2
<u>Cancer irroratus</u>				10
<u>Cancer borealis</u>			1	
<u>Homarus americanus</u>		1	2	5
<u>Pagurus longicarpus</u>				50
<u>Pagurus pollicaris</u>		2		15
Echinodermata				
<u>Asterias forbesi</u>	1			
Pisces				
<u>Psuedopleuronectes</u>				
<u>americanus</u>	>20	18	>25	12
<u>Paralichthys dentatus</u>	1		1	
<u>Prionotus</u> sp.	>15			6
<u>Raja</u> sp.	2			

Table 4-1

Comparison of Sediment Chemical Concentrations from New London Disposal Site with Other Reported Values in or near Long Island Sound

	New London Disposal Site ¹		Benninger ²	Munns ³	Greig ⁴	Boehm ⁵	Wade ⁶
	<u>Reference</u>	<u>NL-II</u>	<u>CLIS-REF</u>	<u>L.I.Sound</u>	<u>L.I.Sound</u>	<u>Block Is.S.</u>	<u>Narr.Bay</u>
Pb	<25	<25-156	50	21-52	7.4-46	---	---
Zn	28-60	73-375	150	17-99	46.3	---	---
Cu	<5-8	9-89	~60	31-96	3.4-33	---	---
Cd	<3	<3	0.30	---	---	---	---
Ni	<24	<24-33	24	---	2.4-18	---	---
Hg	<0.05	<0.05-0.84	---	---	<0.2	---	---
Tot.C ⁷	0.52-1.55	0.5-4.99	2	---	---	0.2-5	1-2
PCBs ⁸	<0.01	<0.01-0.21	0.04	---	---	---	0.009

¹ From all disposal mounds and the Reference Station

² Munns et al (in preparation)

³ Benninger et al. (1979)

⁴ Grieg et al. (1977)

⁵ Boehm and Quinn (1978)

⁶ Wade and Quinn (1979)

⁷ % Total Carbon.

⁸ PCB values are ppb.

Table 4-2

Comparison of Body Tissue Chemical Concentrations in Pitar from New London Disposal Site with Other Reported Values in or near Long Island Sound

(Concentrations in ppm dry weight basis)

	New London Disposal Site		Eisler ¹	Feng ²	Arimoto ³	Munns ⁴
	<u>Reference</u>	<u>NL-II</u>	<u>Narr. Bay</u>	<u>Thames R.</u>	<u>NLON</u>	<u>CLIS-REF</u>
Pb	2.3-6.5	2.7-10.7	11.1-19.2	---	---	---
As	12-14	8-12	---	---	---	---
Zn	130-140	130-200	203-256	---	---	---
Cr	0.36-0.85	0.54-0.71	3.1-7.2	---	---	---
Cu	13-15	16	17-23	16	---	---
Cd	1.1-1.7	0.7-1.3	1.4-2.8	4.1	---	---
Hg	0.07-0.08	0.02-0.09	---	0.16	---	---
Fe	160-300	190-370	272-410	356	---	---
PCBs ⁵	<160-<280	<97-<260	---	---	260-430	250-400

¹ Eisler et al. (1978)

² Feng (1975)

³ Arimoto and Feng (1983). Test organisms were caged mussels at New London Disposal Site.

⁴ Munns et al. (in preparation). Test organisms were caged mussels at Central Long Island Sound Disposal Site Reference station.

⁵ PCB values are ppb.

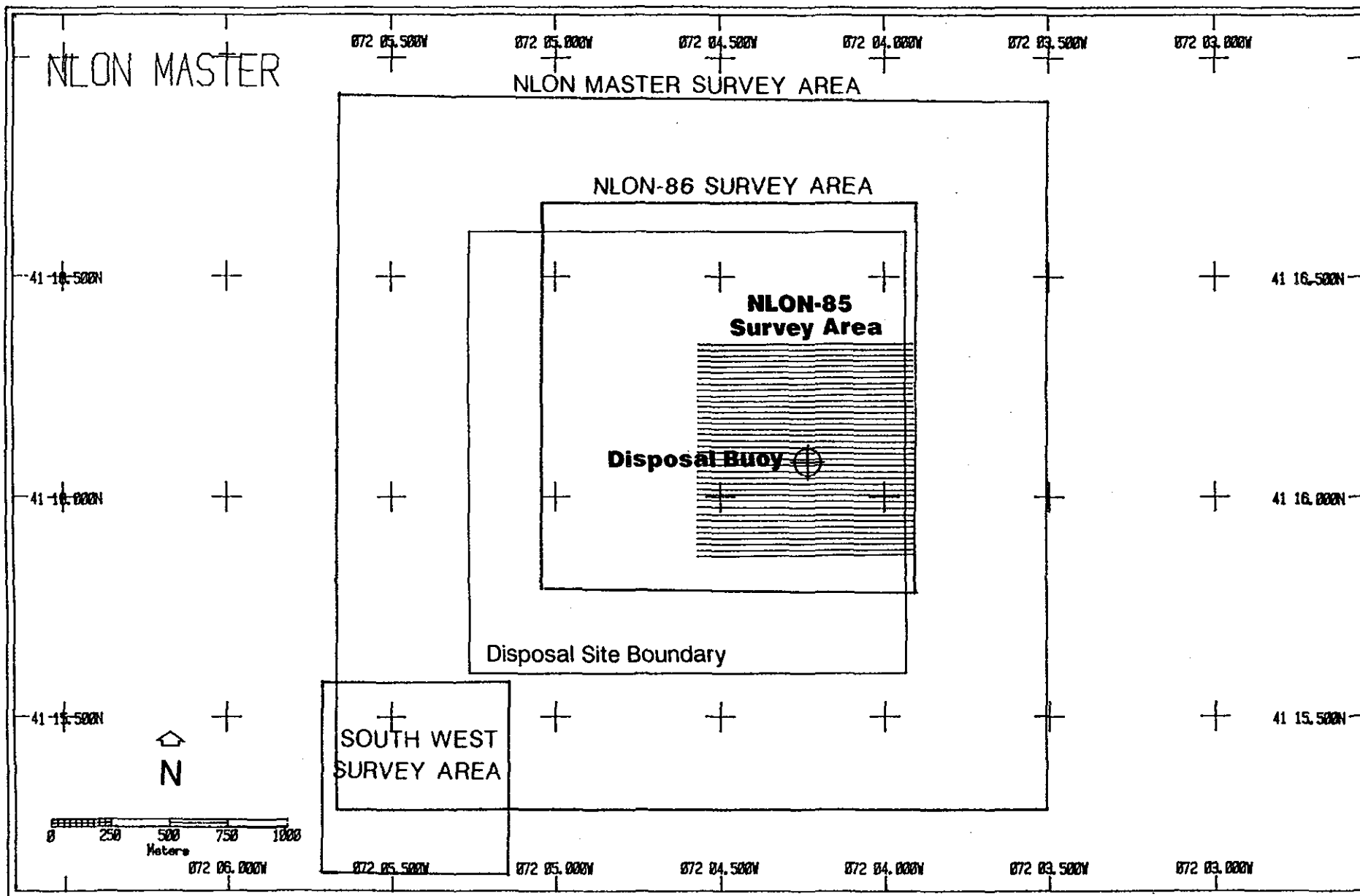

Figure 2-1. Bathymetric survey grids conducted at the New London Disposal Site, 1985-1986.

REMOTS Sediment-Profile Camera

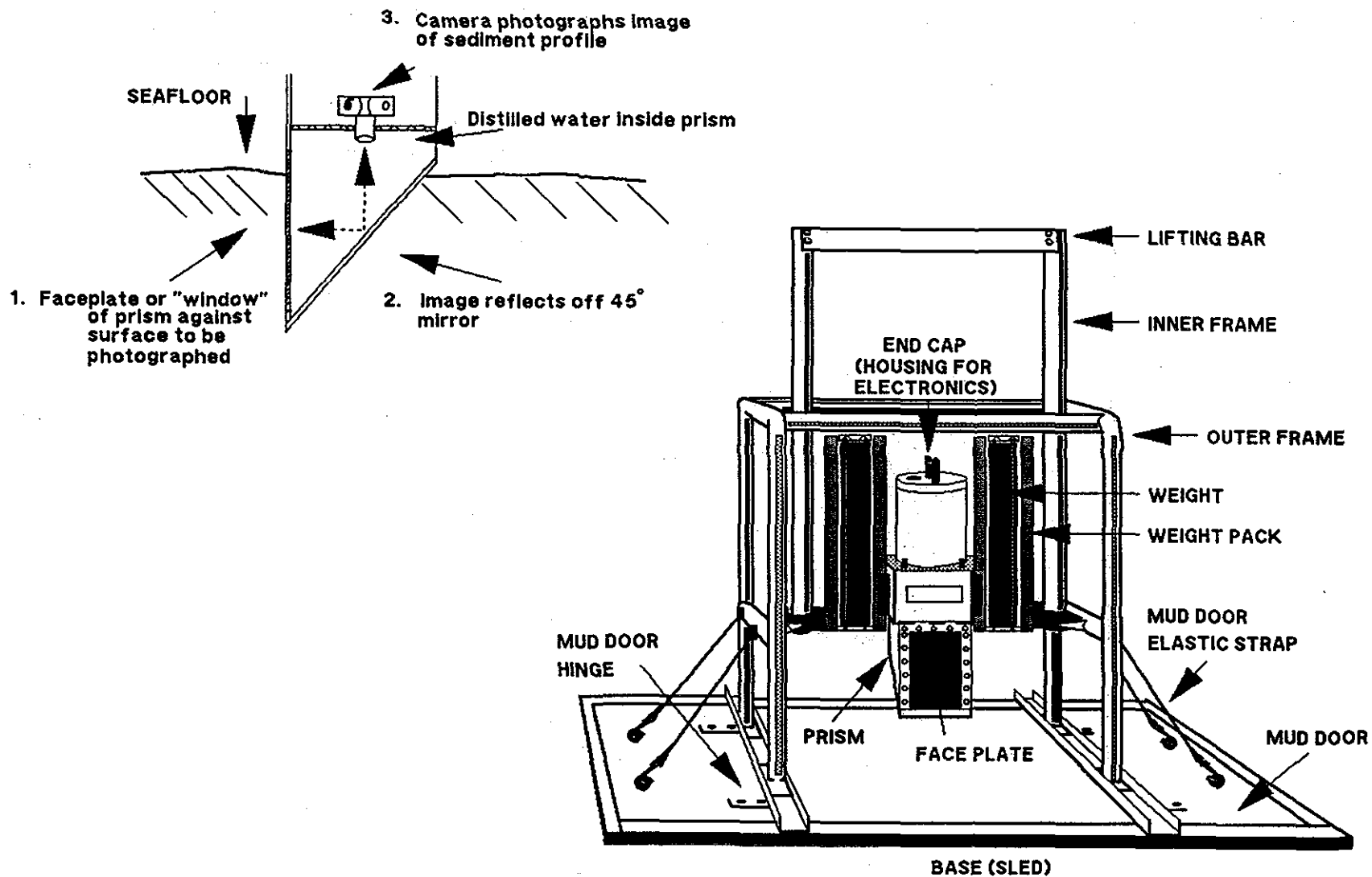
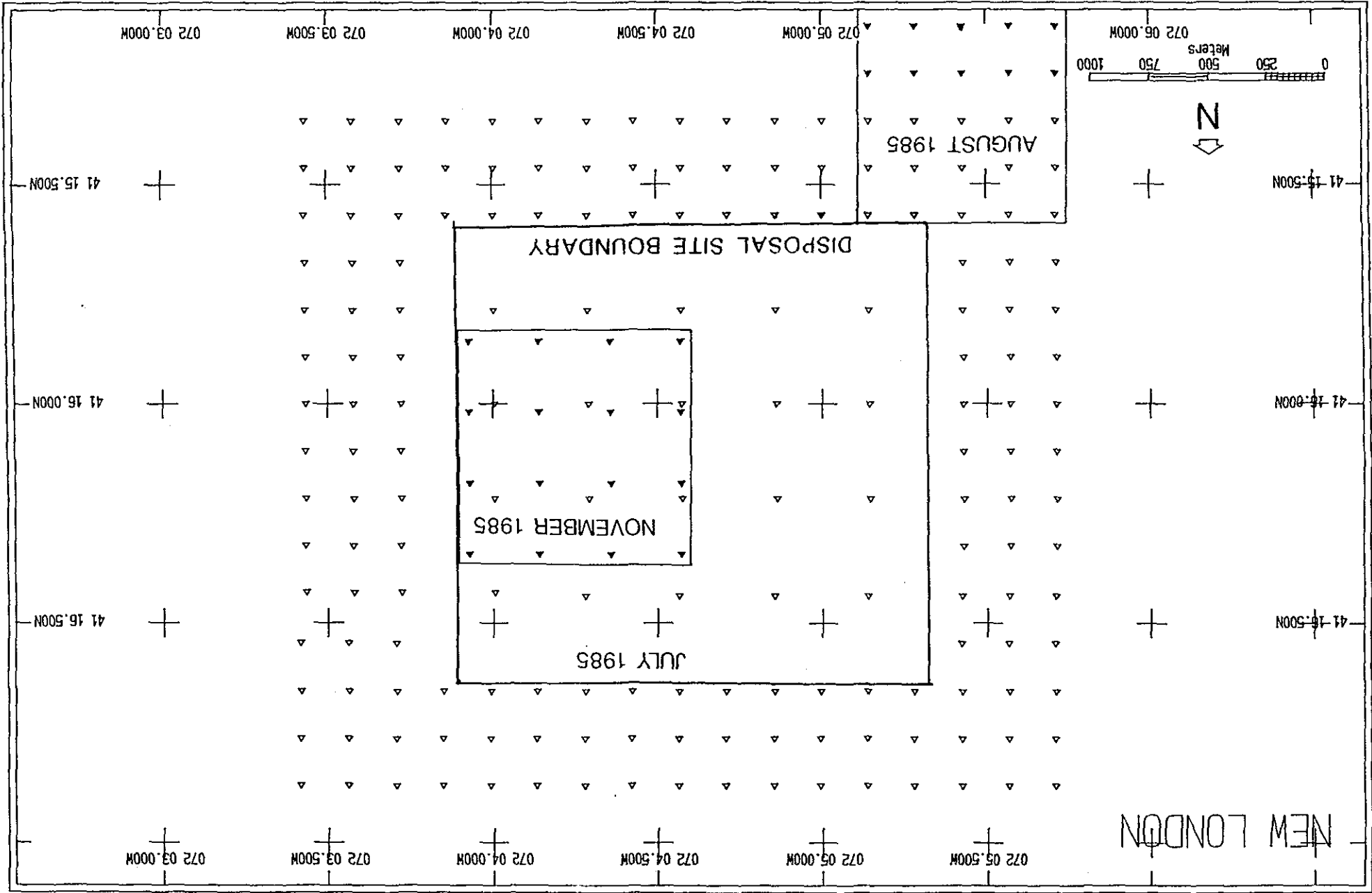

Figure 2-2. The REMOTS® sediment-profile camera, Benthos model 3731.

Figure 2-3. REMOTS® station locations at the New London Disposal Site in 1985. The black triangles indicate stations sampled in August and November 1985.



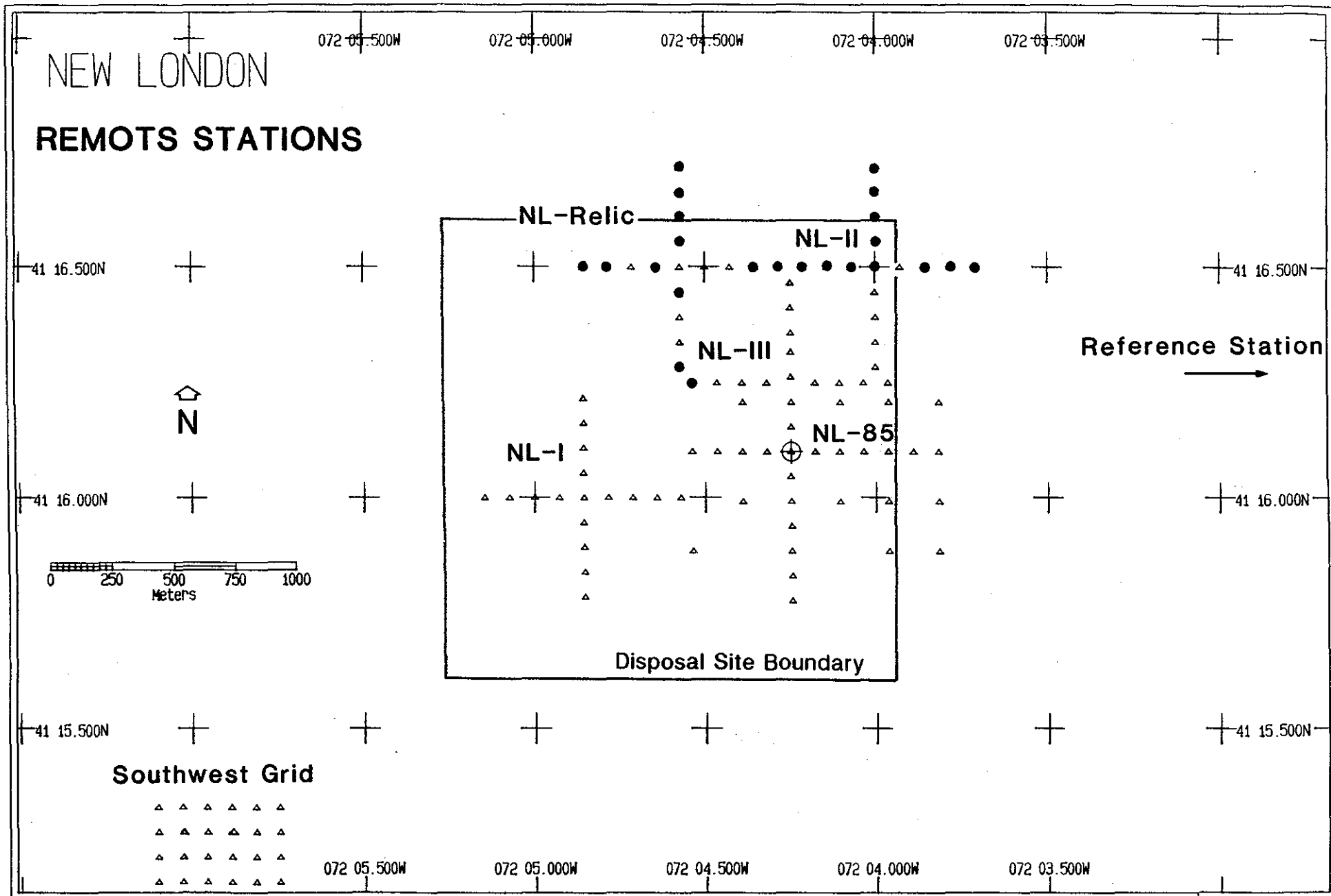

Figure 2-4. REMOTS® stations occupied on the five disposal mounds ("NL-" designation) during the July 1986 survey at the New London Disposal Site. Black circles represent stations where no data were obtained. The NL-85 sampling grid was initially sampled in January 1986.

REMOTS DATA SHEET
Science Applications

PROJECT: NLON STATION: 200N
FIELD DATE: 7/29/86 FRAME #: 29
Measurements By: KK Time of Photo: 10:15
Data Record #: 9

***** PHYSICAL - CHEMICAL PARAMETERS *****

1. Grain Size:
Major Mode: 4-3 ϕ Range: $\geq 4-0 \phi$
2. Total Prism Penetration Depth:
Minimum: 10.75 cm. Maximum: 11.9 cm. Average: 11.33 cm.
3. Surface Boundary Roughness: .92 cm. ----- Unknown Origin
4. Mud Clasts
of Clasts: 0
Average Diameter: 0 cm. Status: NA
5. Mean Redox Depth: 3.04 cm.
6. Redox Contrast:
Bright Level: 21 Dark Level: 0 Delta value: 21
7. Redox Rebound (former distance from sed. surface): Not Present
8. Methane Gas Pockets: Not Present
Number: 0 Area: 0 sq. cm.
Min. Range: 0 cm. Max. Range: 0 cm. Average Depth: 0 cm.
9. Low Dissolved Oxygen in Overlying Water: No
10. Dredged Material thickness (cm.): Not Present
11. Additional Measurement: 3.43 cm. Label: SPPCH
12. Comment: S/M RED.SED.@ SURF

***** BIOLOGICAL PARAMETERS *****

13. Epifauna: None Visible
14. Tube Density (#/linear cm.): 0
15. Tube Type: NA
16. Fecal Pellet layer:
Min. Thickness: 0 cm. Max. Thickness: 0 cm. Average: 0 cm.
17. Microbial Aggregations Present?: 0
18. Feeding Voids -- Average Depth: 0 cm.
Number: 0 Minimum Depth: 0 cm. Maximum Depth: 0 cm.
19. Faunal Dominants:
20. Apparent Species Richness:
21. Successional Stage: STAGE 1 ON STAGE 3
22. Organism-Sediment Index: 10

Figure 2-5. A REMOTS® data sheet.

SOUTHWEST
SURVEY AREA

DISPOSAL SITE BOUNDARY

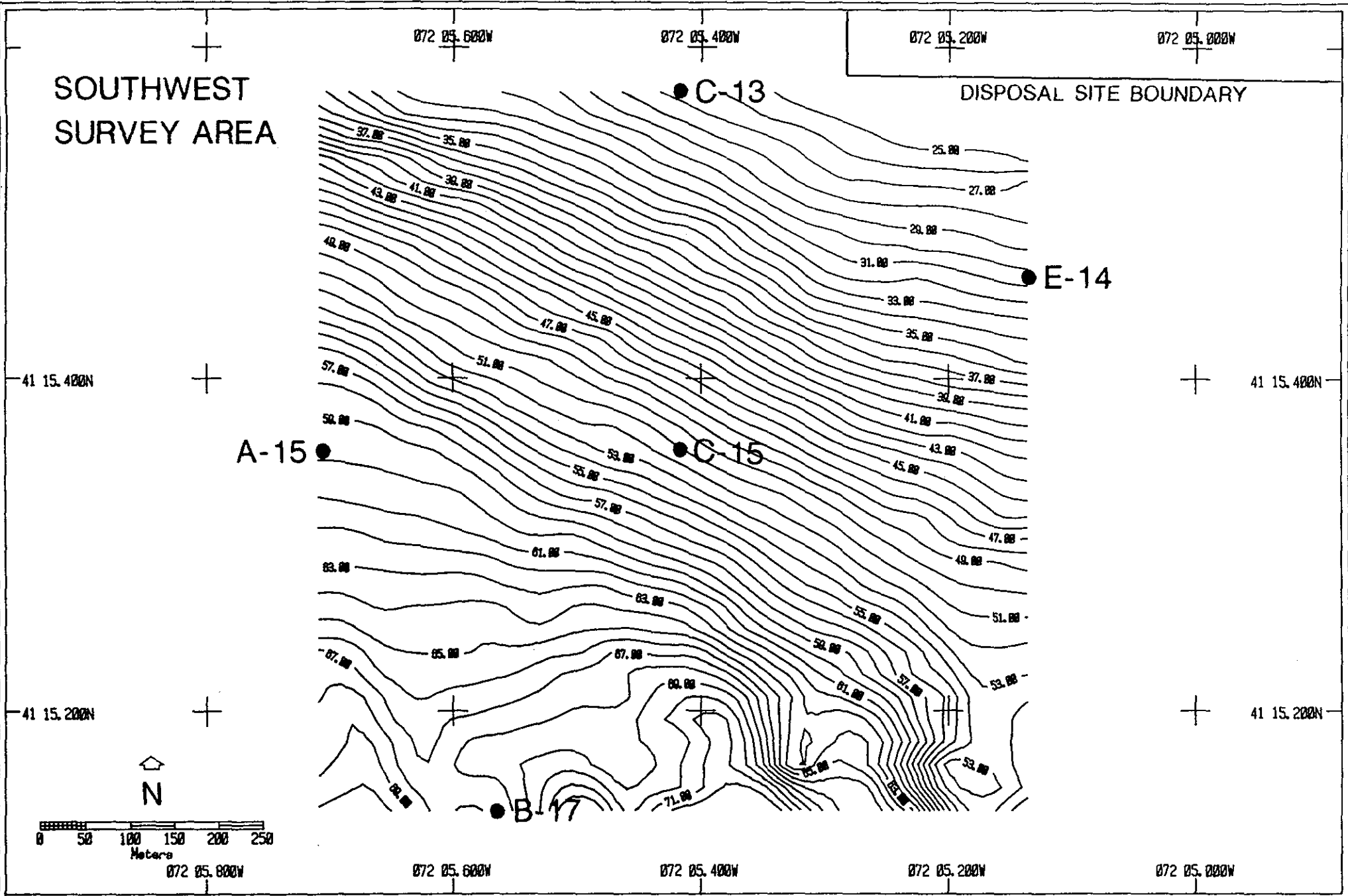

Figure 3-2. Contoured bathymetric chart of an area immediately southwest of the New London Disposal Site, July 1985. Depths are in meters. Sediment sampling stations are indicated.

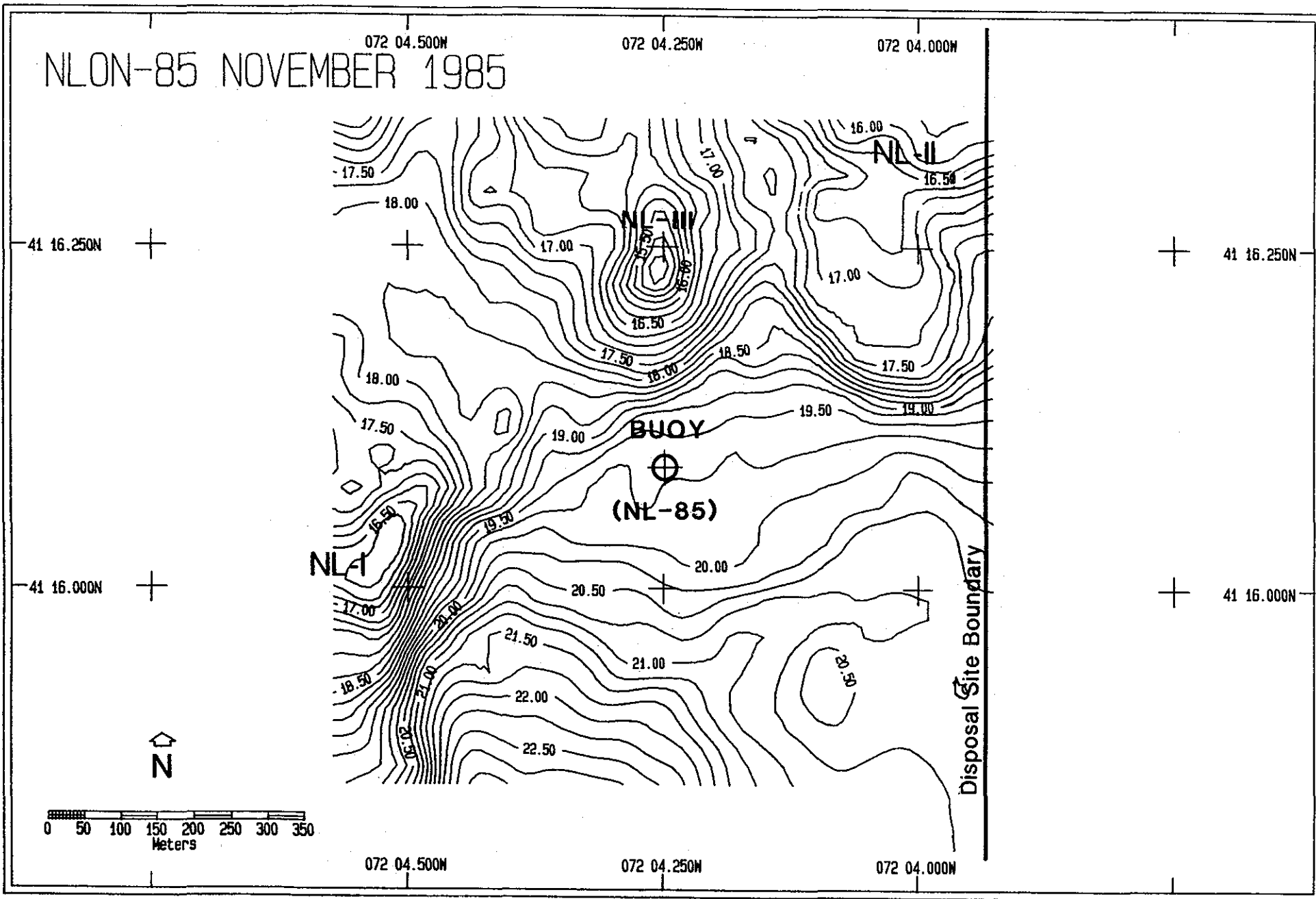

Figure 3-3. Contoured bathymetric chart of the NLON-85 survey area, November 1985. Depths in meters.

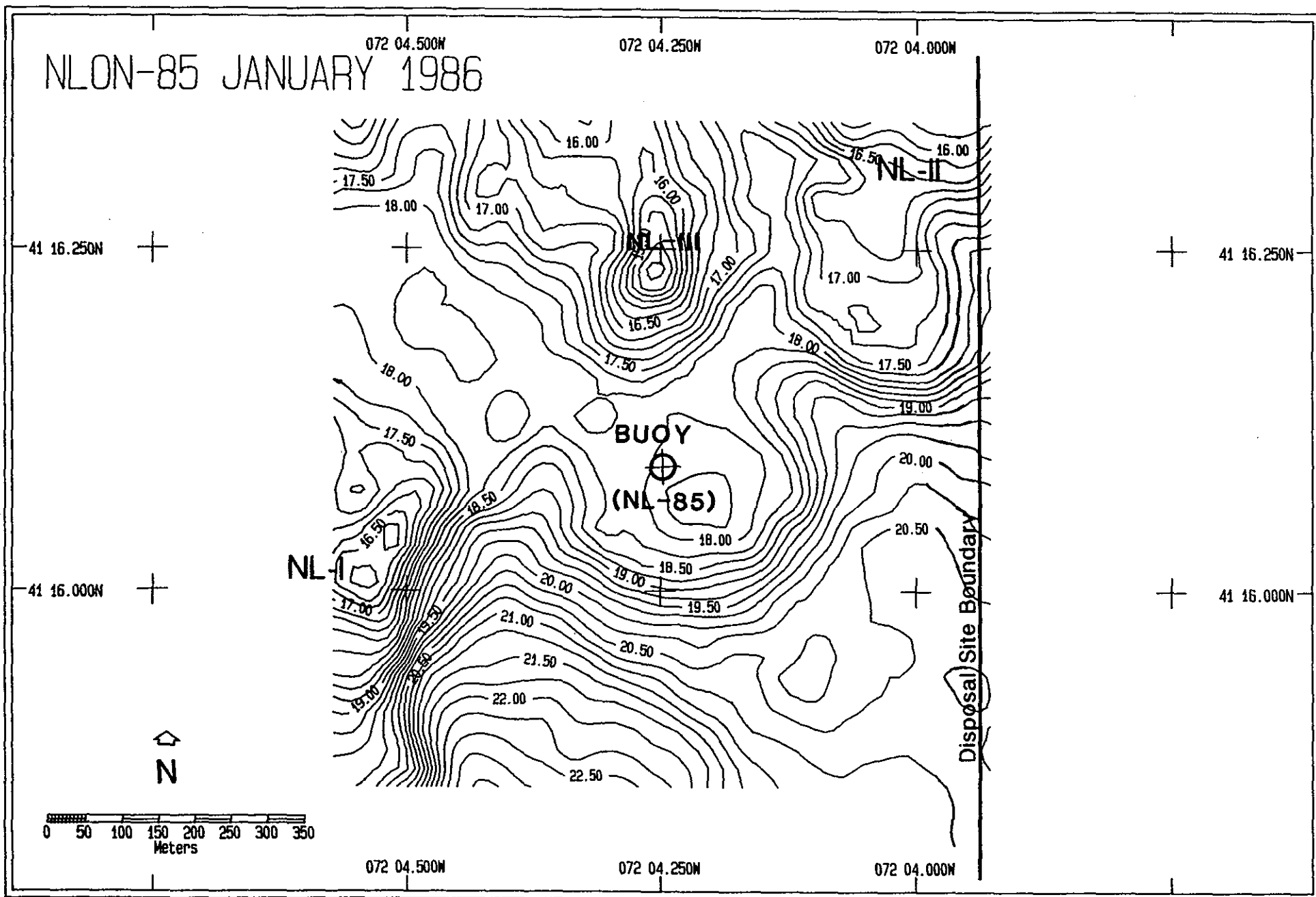

Figure 3-4. Contoured bathymetric chart of the NLON-85 survey area, January 1986. Depths in meters.

NLON-85 POST - PRE-DISPOSAL

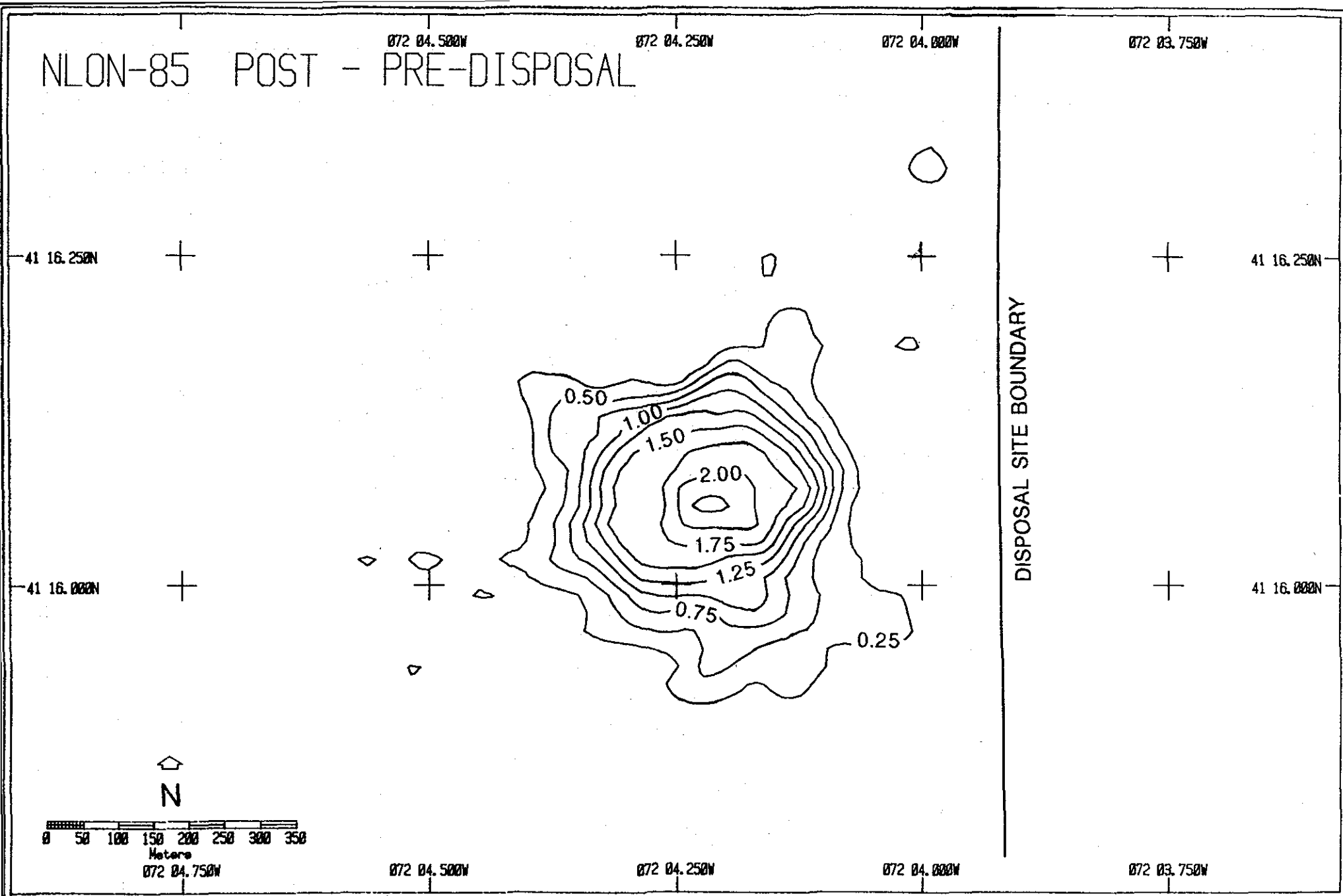

Figure 3-5. Contoured chart of depth differences between pre-and post-disposal at the NLON-85 survey area. Values in meters.

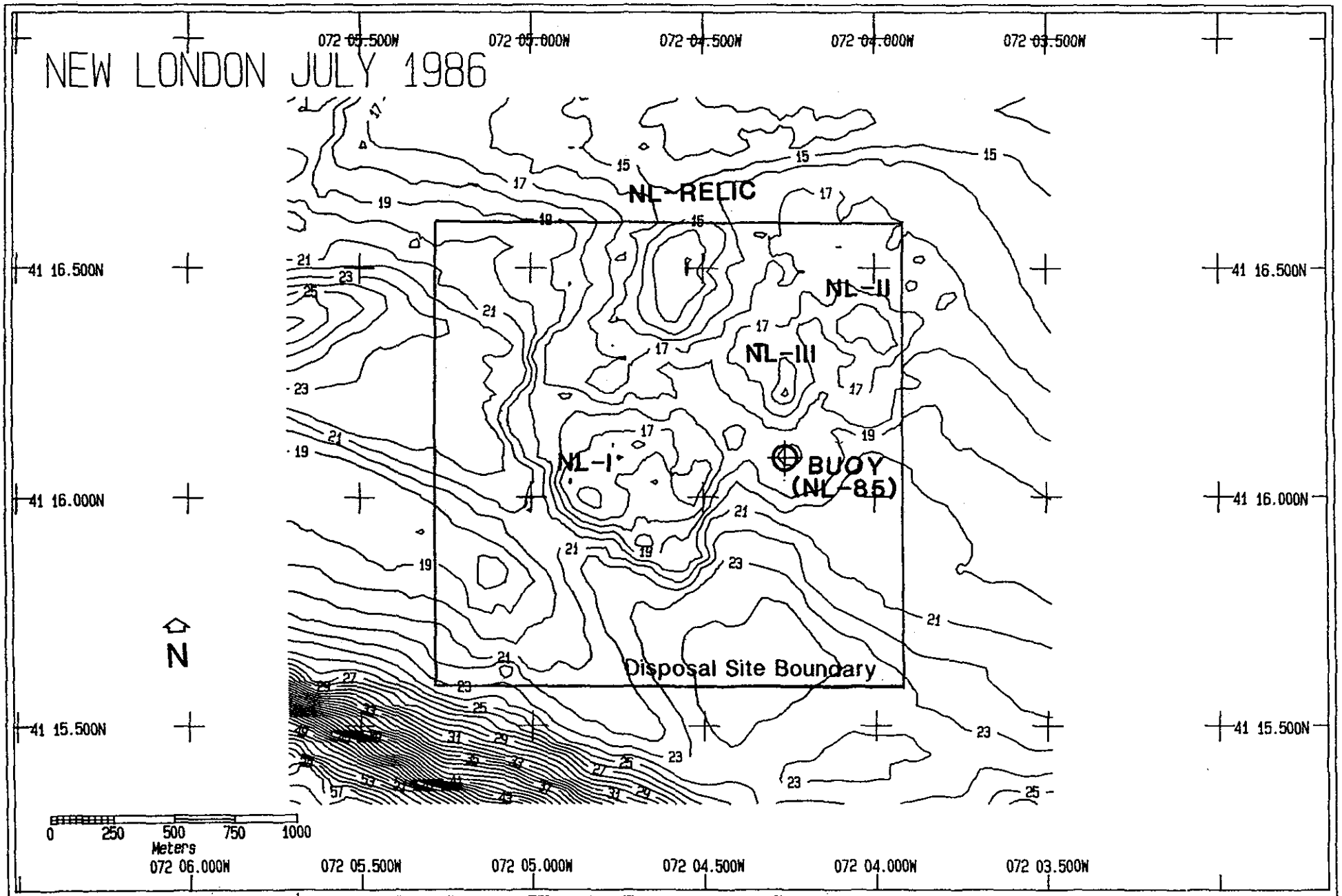

Figure 3-6. Contoured bathymetric chart of the New London Disposal Site, July 1986. Depths in meters.

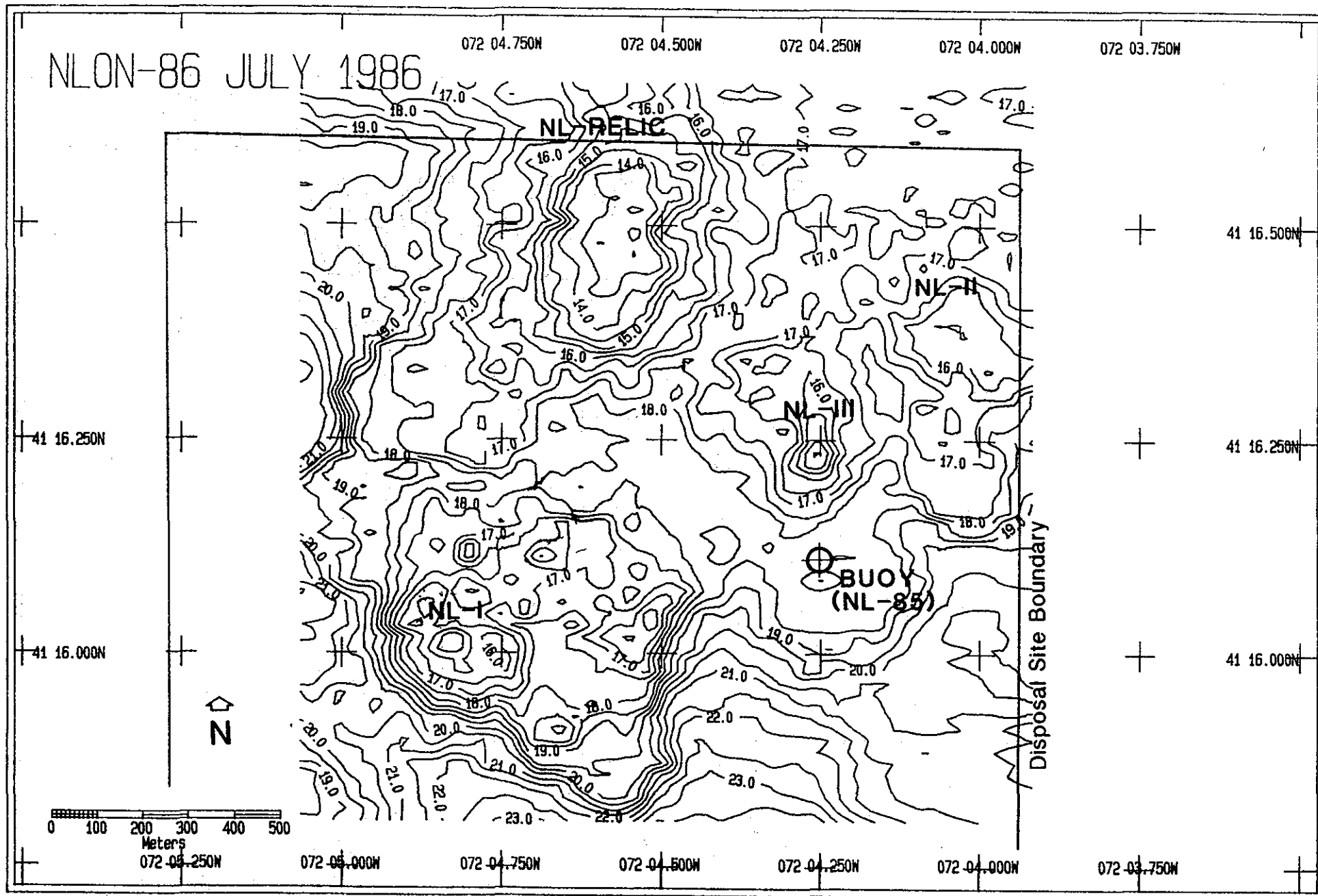

Figure 3-7. Contoured bathymetric chart of the NLON-86 survey area, July 1986. Depths in meters.

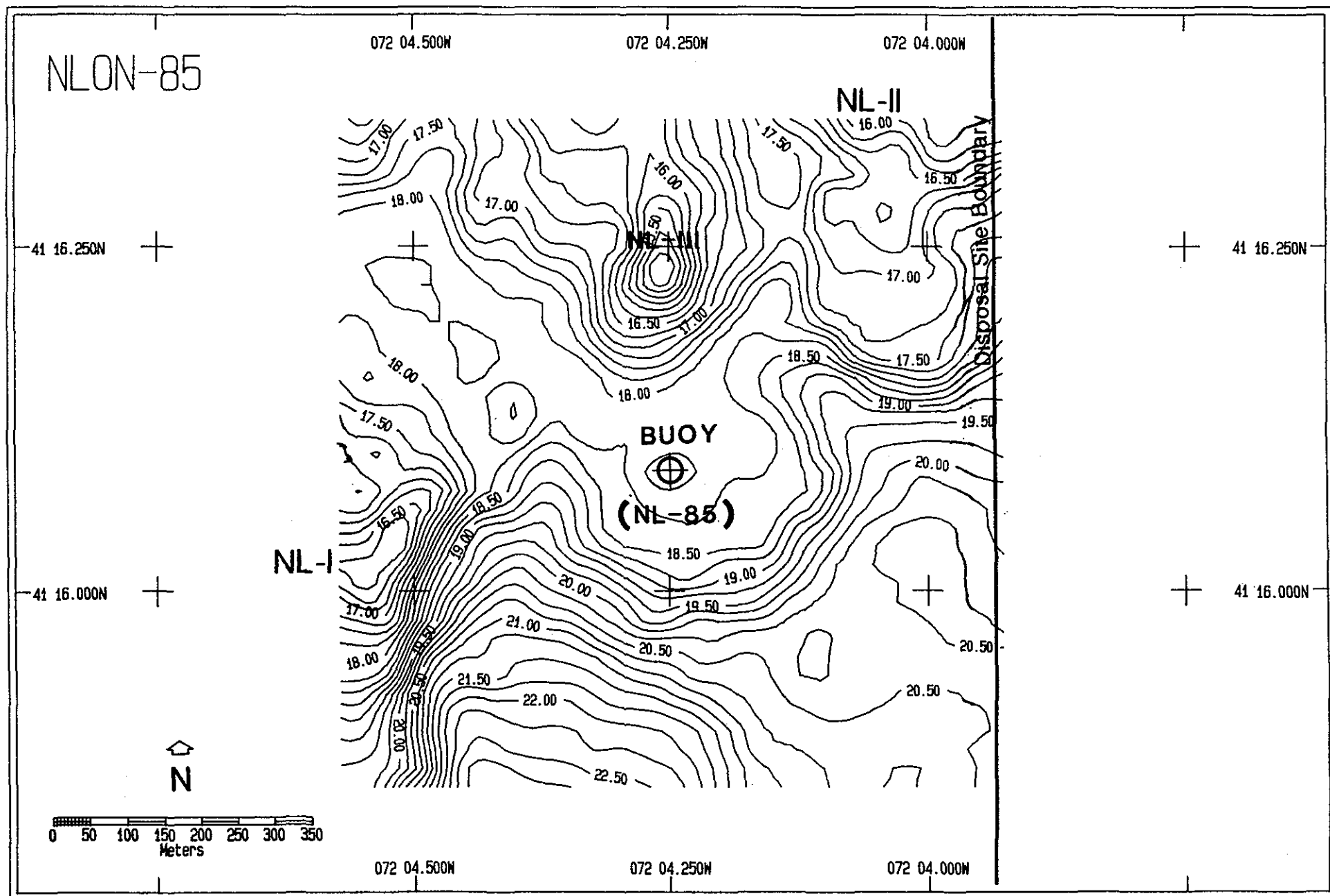
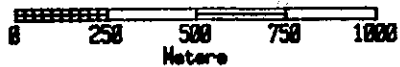

Figure 3-8. Contoured bathymetric chart of the NLON-85 survey area, July 1986. Depths in meters.

NEW LONDON SIDESCAN

Mercator Projection

Skew: 000 deg



41 17.500N

41 16.500N

41 15.500N



072 06.000W

072 05.500W

072 05.000W

072 04.500W

072 04.000W

072 03.500W

072 03.000W

072 05.500W

072 05.000W

072 04.500W

072 04.000W

072 03.500W

072 03.000W

41 17.000N

41 16.500N

41 16.000N

41 15.500N

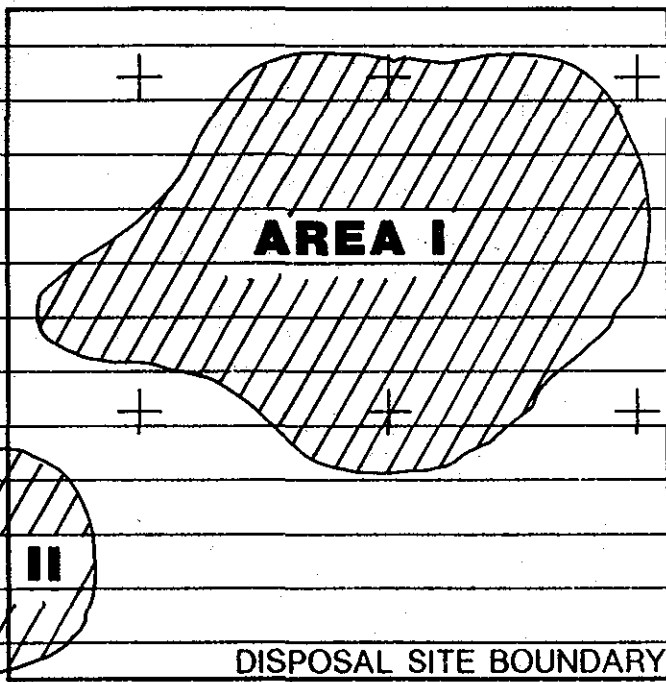

DISPOSAL SITE BOUNDARY

SURVEY LANES

Figure 3-9. Results of the side scan survey at the New London Disposal Site, August 1985.

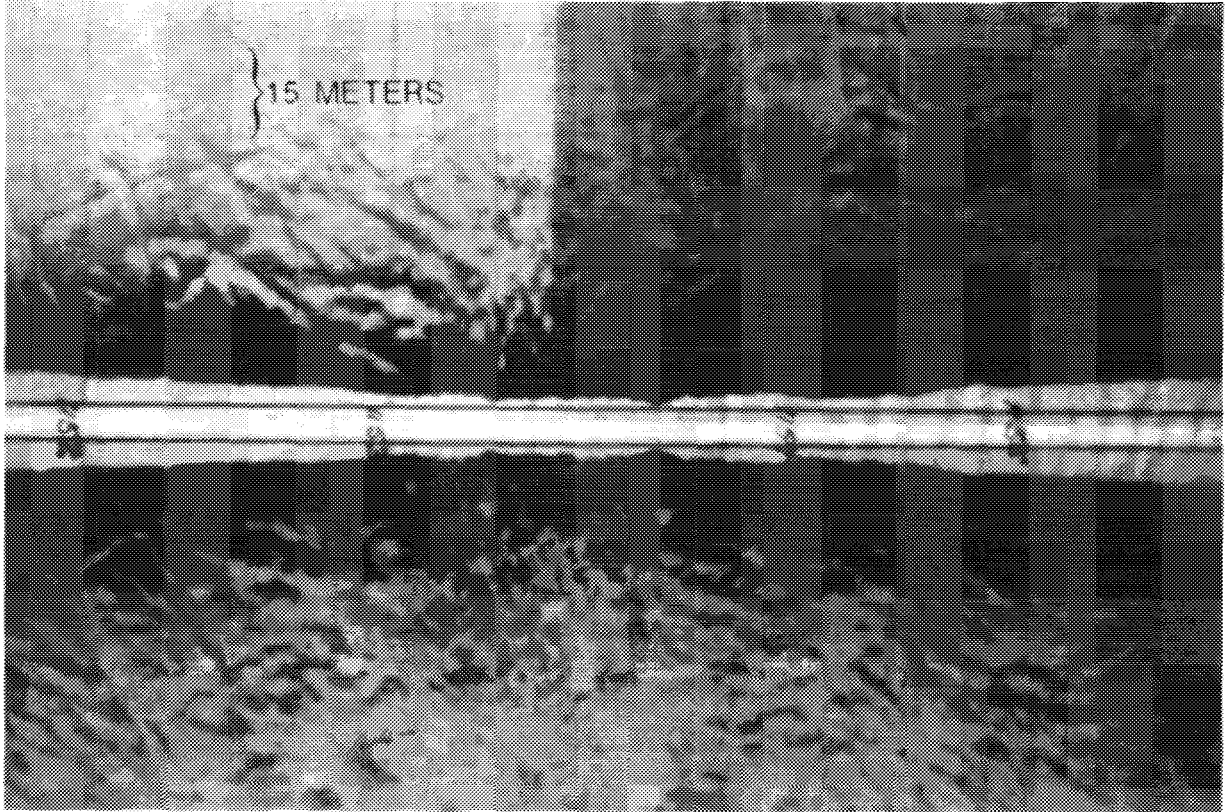

Figure 3-10. Photograph of side scan record at the NL-RELIC mound in the New London Disposal Site.

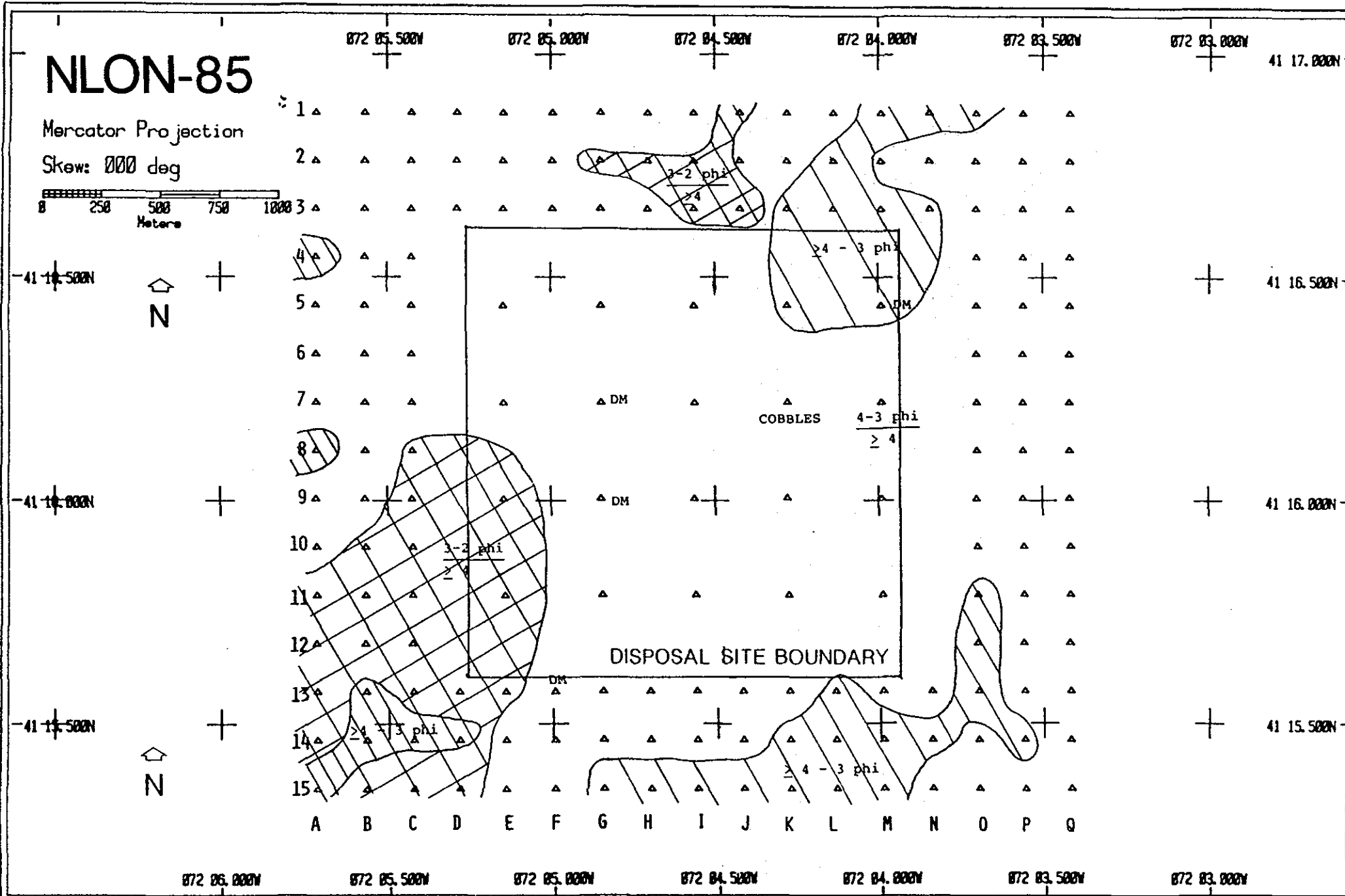

Figure 3-11. The distribution of grain-size major mode at the New London Disposal Site, July 1985. The cross hatching defines regions dominated by fine sand overlying silt-clay, the hatching defines areas consisting of silt-clay mixtures, and the unmarked area is characterized by very fine sand overlying silt-clay. The distribution of dredged material within the site is indicated by "DM".

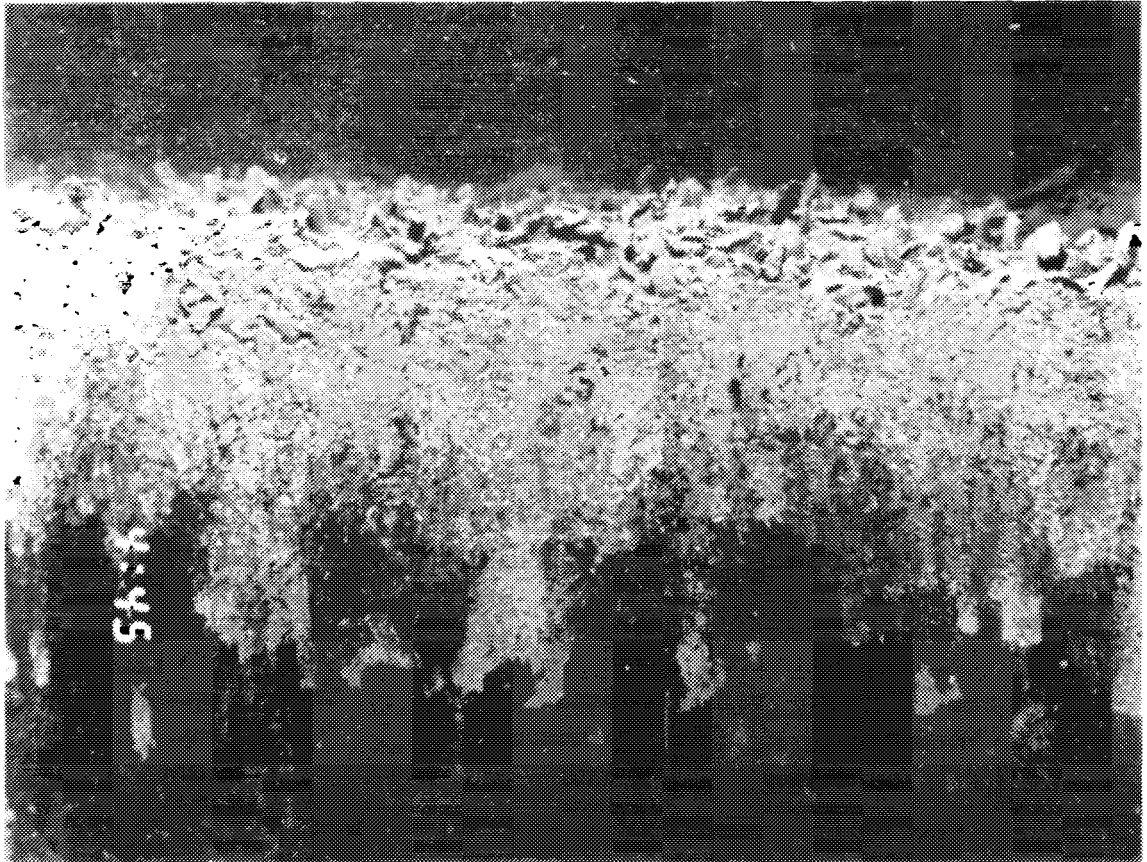

Figure 3-12 A REMOTS® photograph from New London station Q-7. Extremely low reflectance sediment, indicating the presence of highly reduced (high BOD and COD) material, is evident at depth. Scale = 1X.

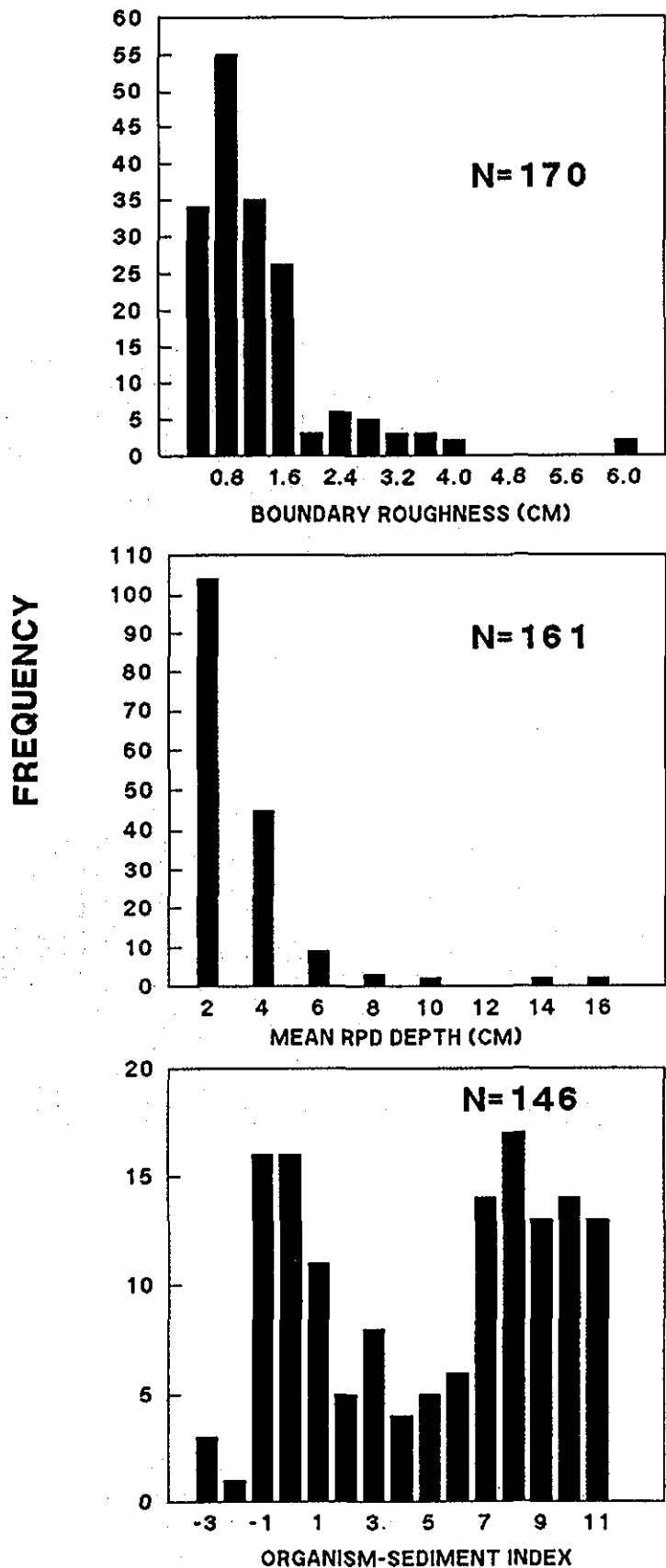

Figure 3-13. Frequency distributions of boundary roughness, RPD, and OSI values for the New London Disposal Site, July 1985.

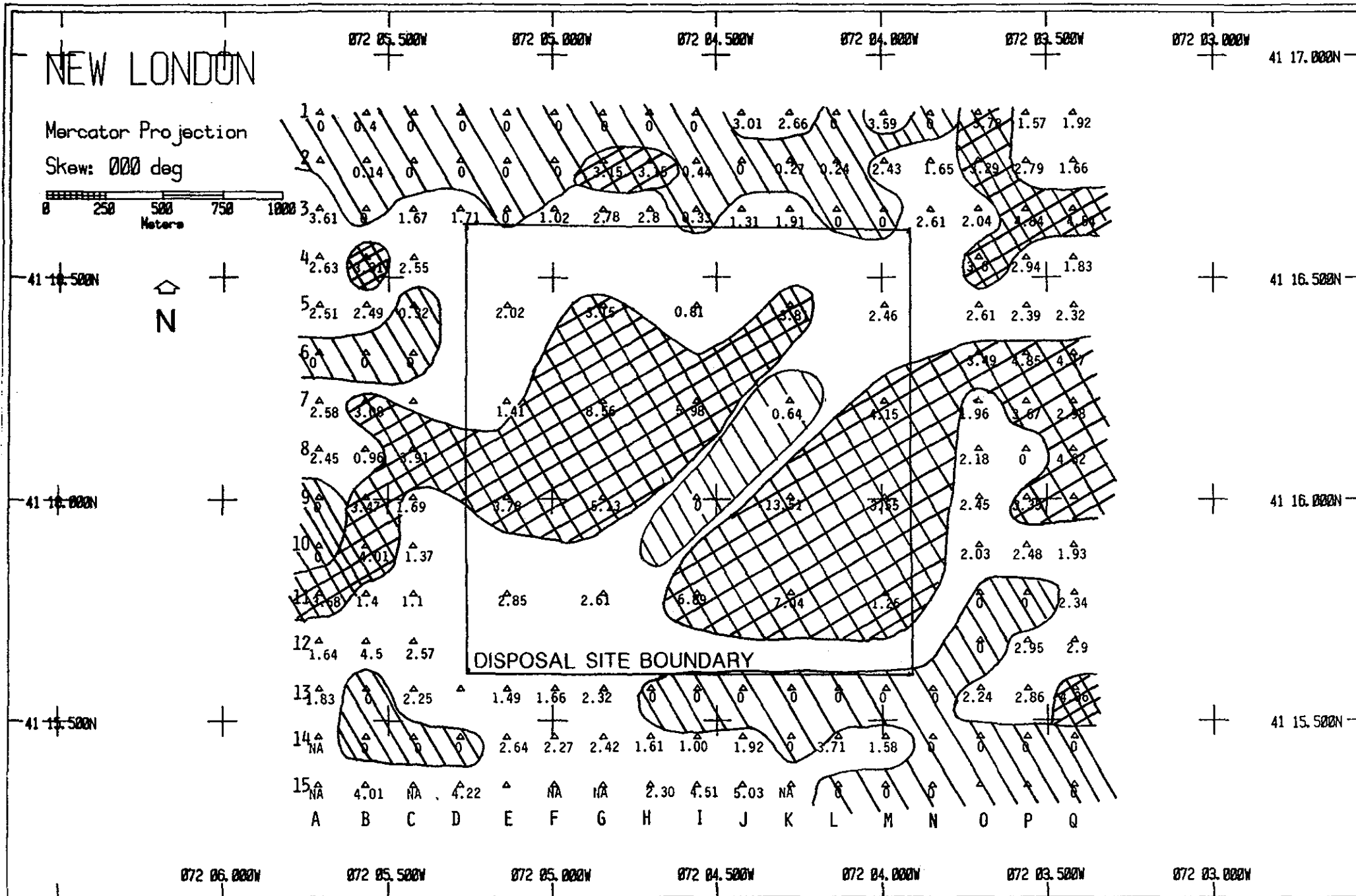

Figure 3-14. The distribution of mean apparent RPD depths at the New London Disposal Site, July 1985. Hatched areas define where RPD depths were less than 1.00 cm, while cross-hatching delimits areas with RPD depths > 3.00 cm. NA indicates data not available.

NEW LONDON

Mercator Projection
 Skew: 000 deg

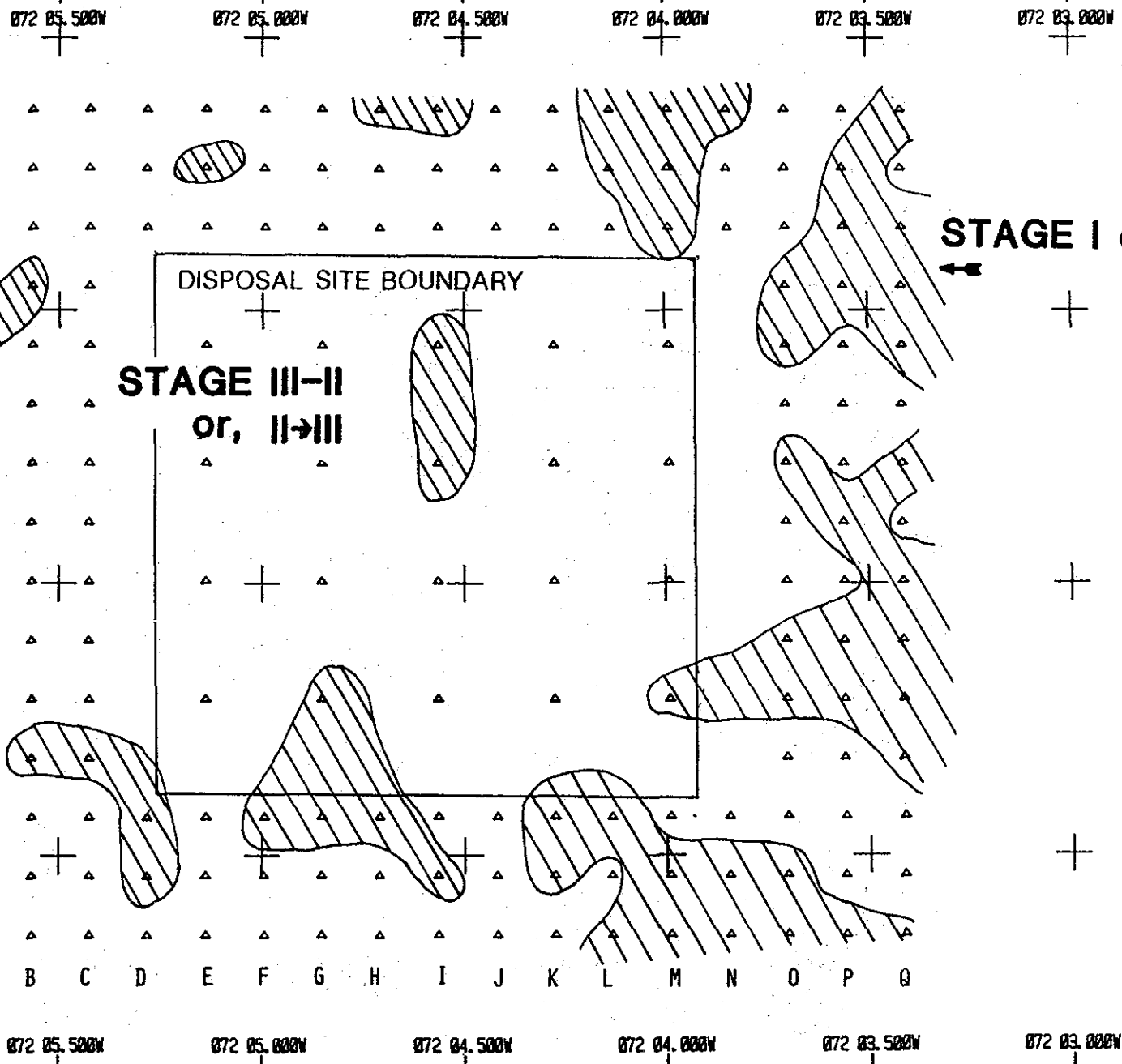
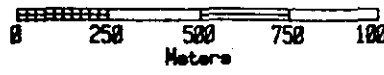

Figure 3-15. The distribution of infaunal successional stages at the New London Disposal Site, July 1985. The hatched areas were characterized by Stage I or II seres. The remainder of the area exhibited Stage III-II or II->III assemblages.

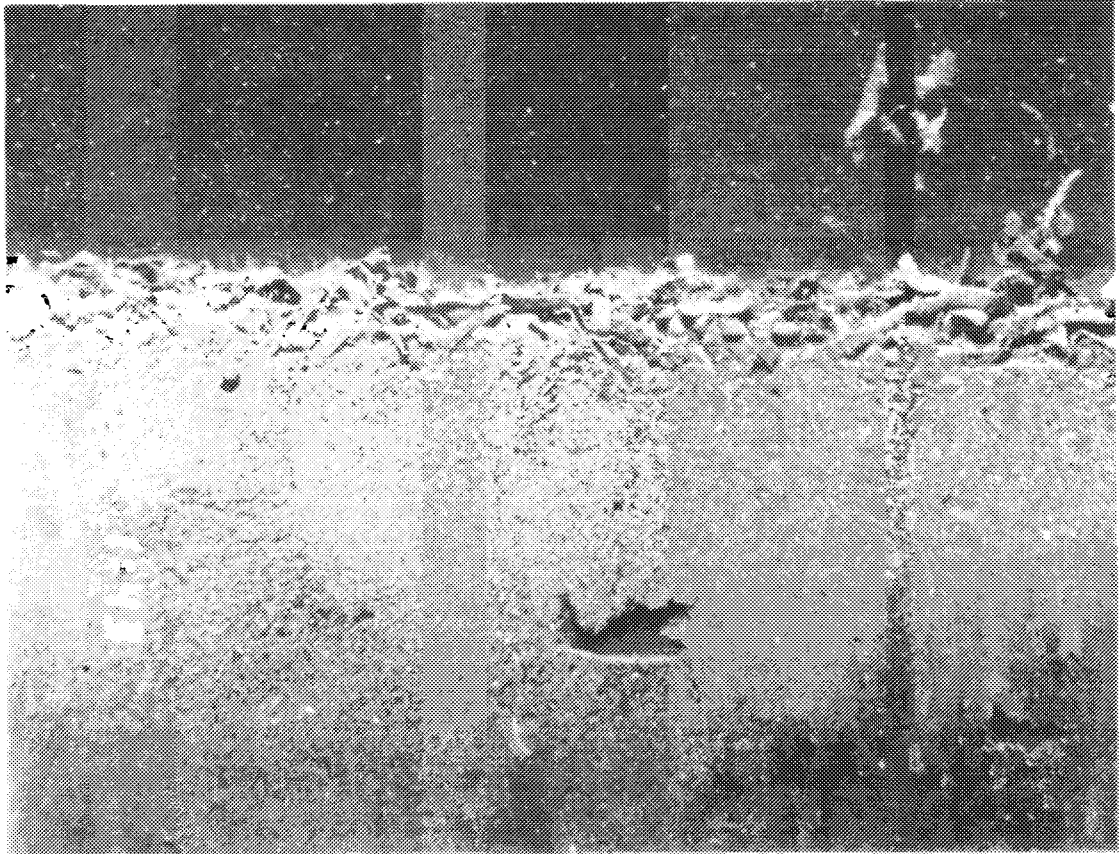

Figure 3-16. A REMOTS® photograph from New London station O-3 showing a retrograde Stage II assemblage. The surface amphipod tube mat is severely stressed and shows evidence of decomposition. Scale = 1X.

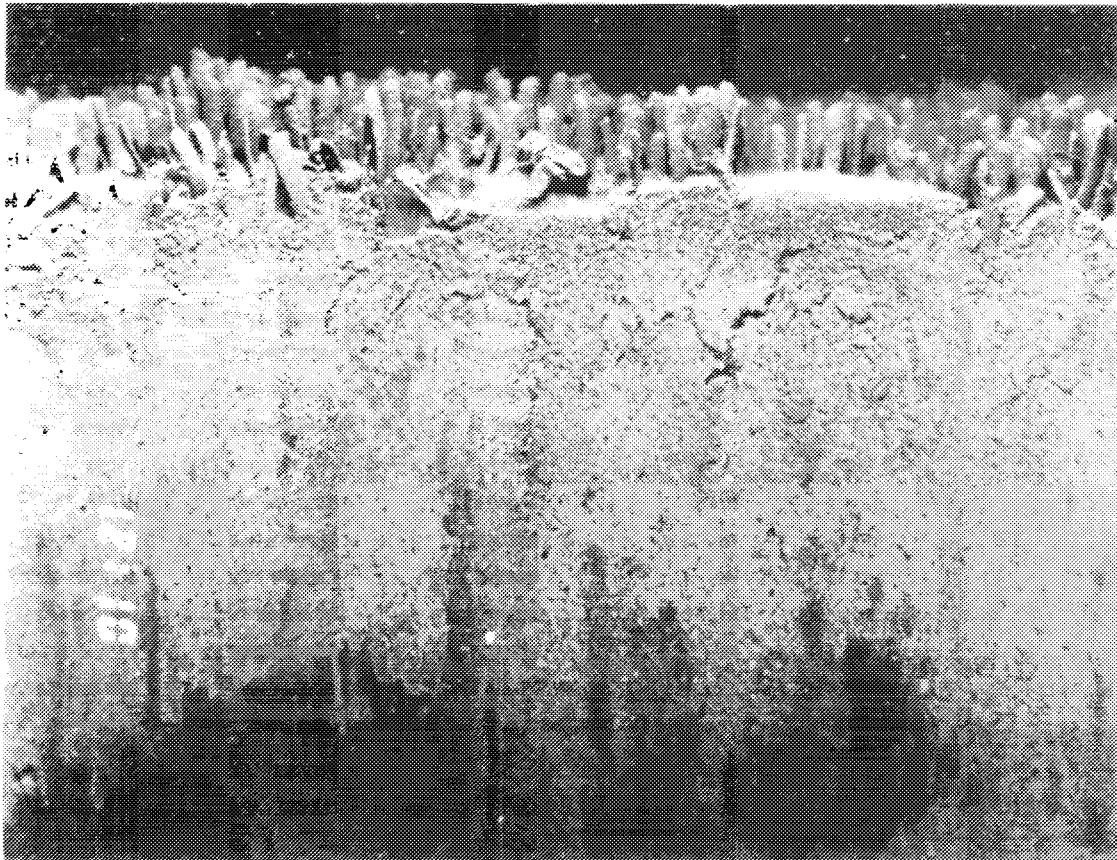

Figure 3-17. A REMOTS® photograph from New London station Q-3 showing a healthy (Stage II) amphipod tube mat. Scale = 1X.

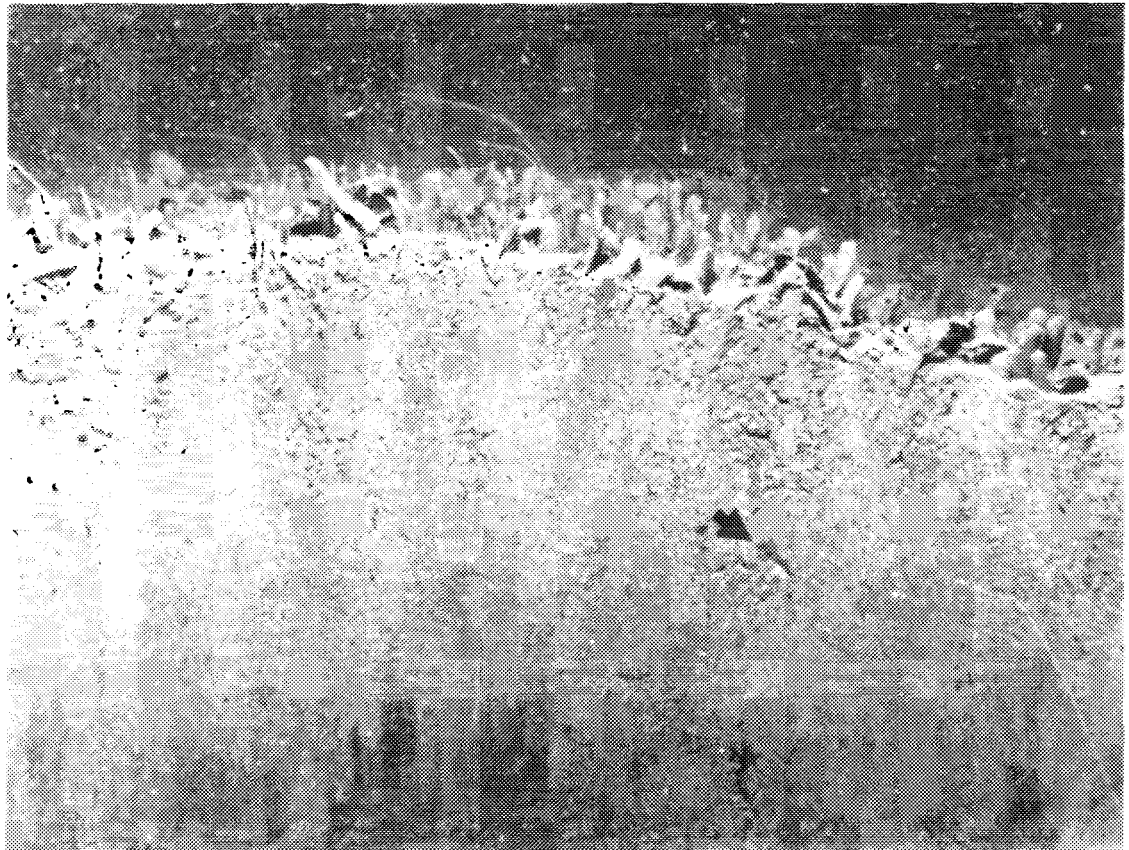

Figure 3-18. A REMOTS® photograph from New London station O-1 showing a Stage II--> III assemblage (Stage II going to Stage III). A partially developed feeding void at depth (arrow) indicates that Stage III infauna are colonizing this area, which is characterized by a Stage II surface tube mat. Scale = 1X.

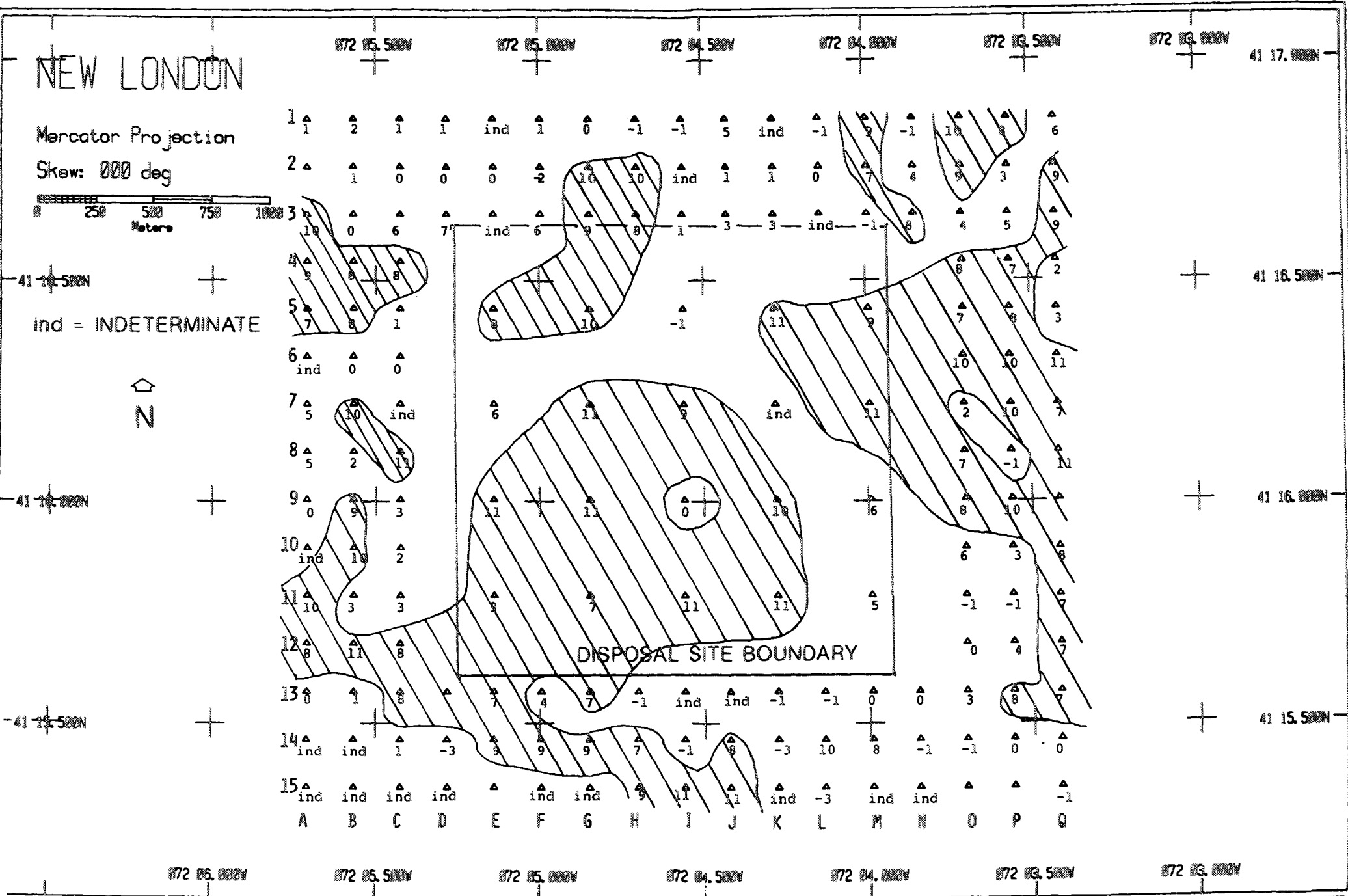

Figure 3-19. The distribution of OSI values at the New London Disposal Site, July 1985. The hatching defines areas with OSI values > +6.

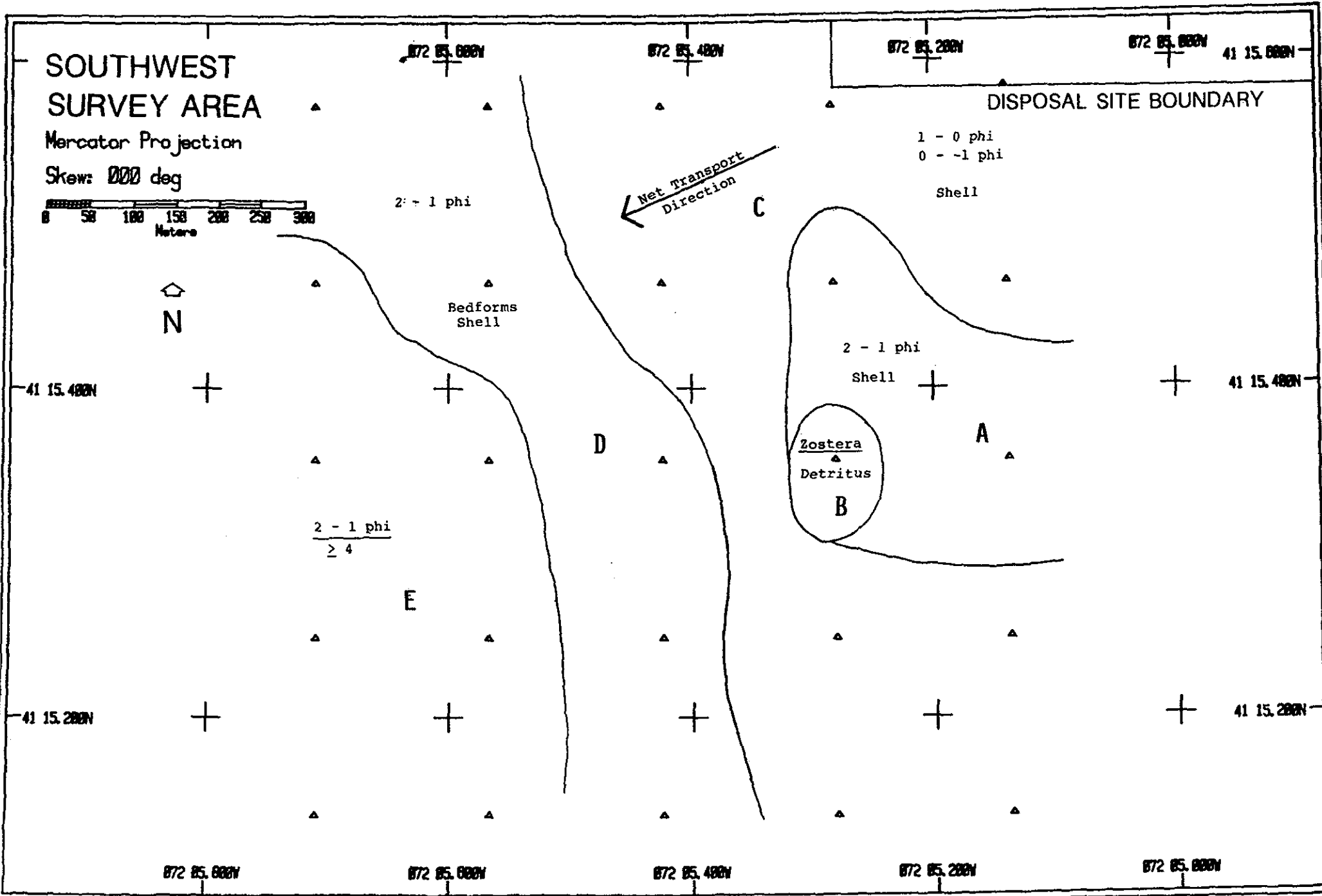

Figure 3-20. The distribution of grain-size major mode at the Southwest survey area, August 1985. Five sedimentary facies, A through E, were identified (see text for further discussion).

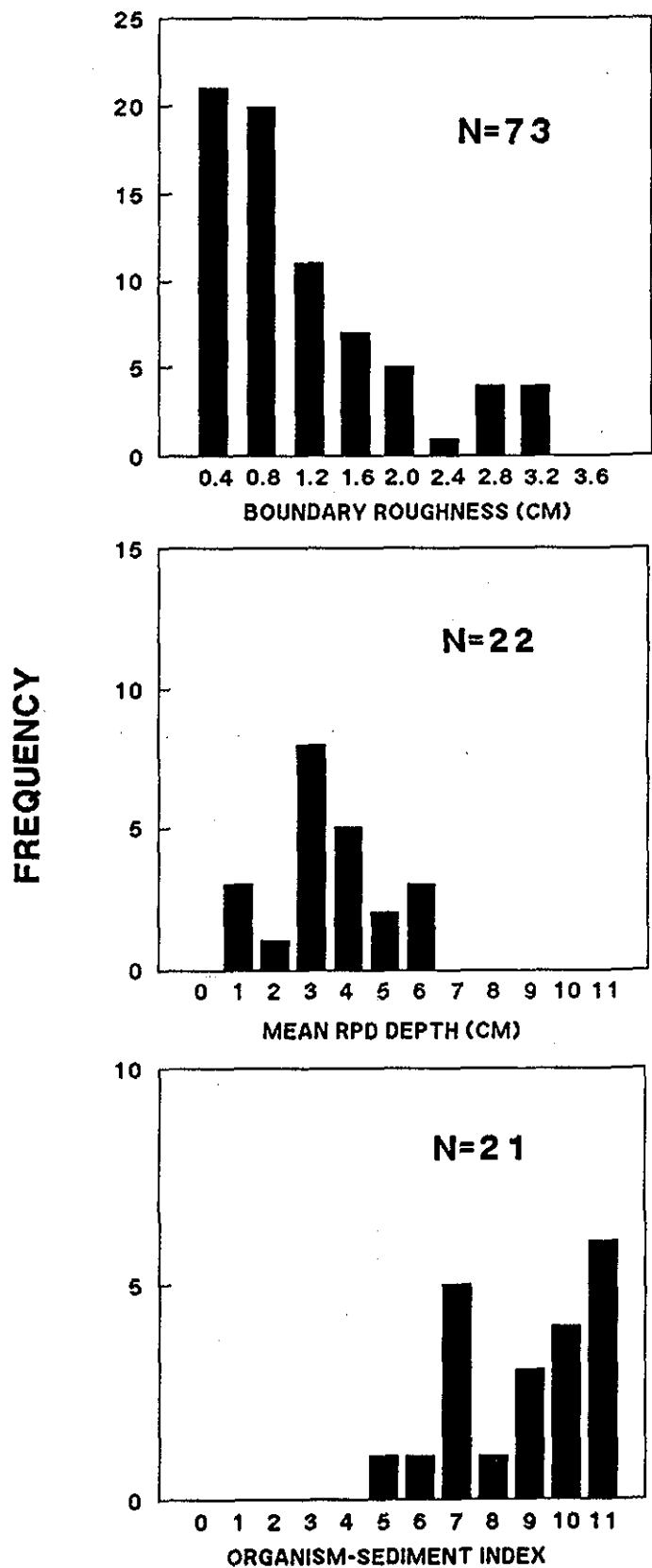

Figure 3-21. Frequency distributions of boundary roughness, RPD, and OSI values for the Southwest survey area, August 1985. RPD and OSI values were only obtained at about 25% of the stations due to insufficient camera prism penetration.

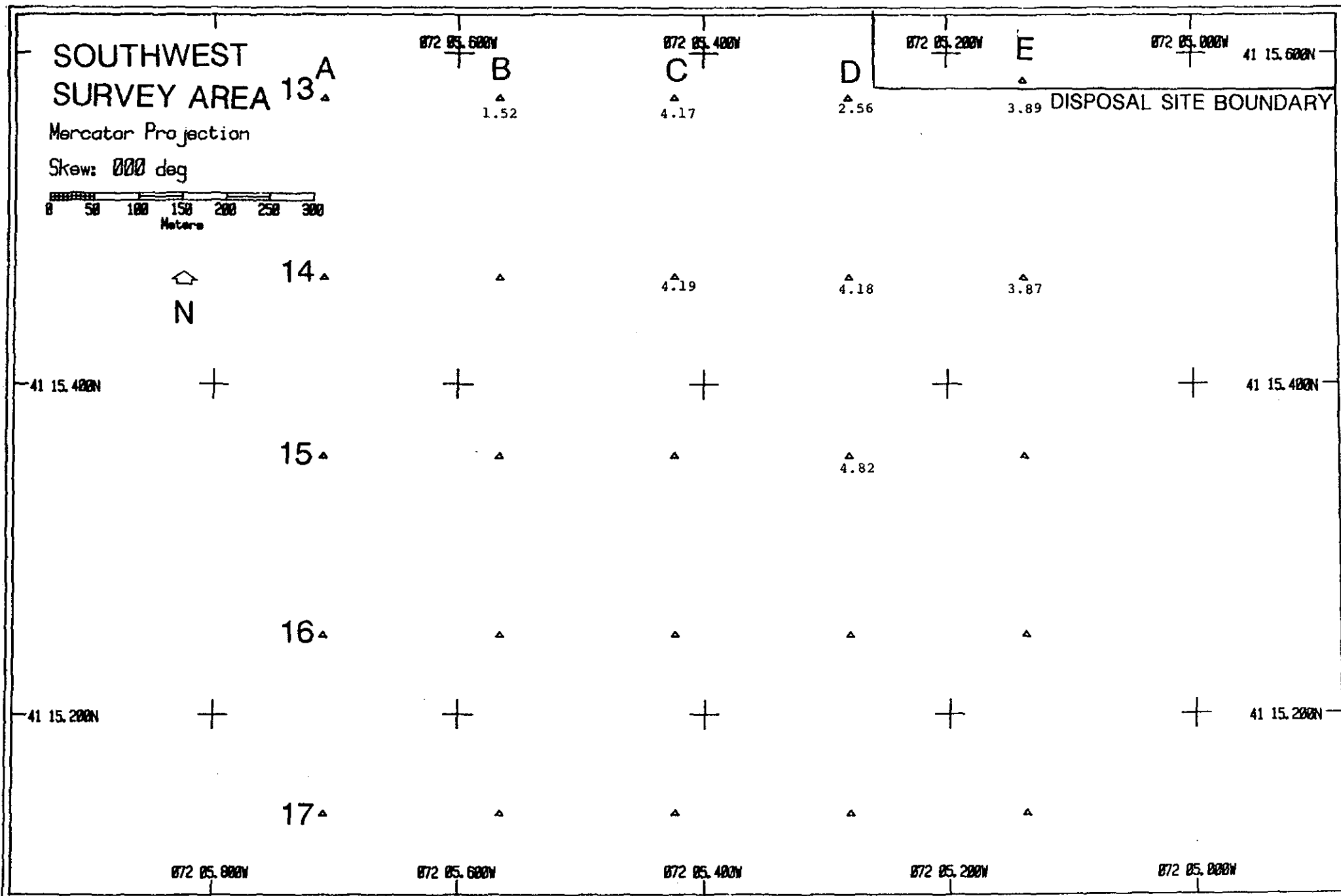
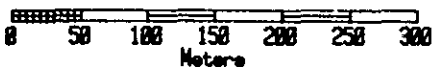

Figure 3-22. The distribution of mean apparent RPD depths at the Southwest survey area, August 1985. RPD depths could not be determined at unlabeled stations due to insufficient camera prism penetration depths.

SOUTHWEST SURVEY AREA 13^Δ

Mercator Projection

Skew: 000 deg



14^Δ

15^Δ

16^Δ

17^Δ

072 05. 600W

B

III-I(3)

072 05. 400W

C

III-I(2),
III-I

072 05. 200W

D

I, III, III-I

E

III(2), III-II

072 05. 000W

41 15. 600N

DISPOSAL SITE BOUNDARY

41 15. 400N

41 15. 400N

41 15. 200N

41 15. 200N

072 05. 800W

072 05. 600W

072 05. 400W

072 05. 200W

072 05. 000W

Figure 3-23. The distribution of infaunal successional stages at the Southwest survey area, August 1985. Successional stage was indeterminate at unlabeled stations.

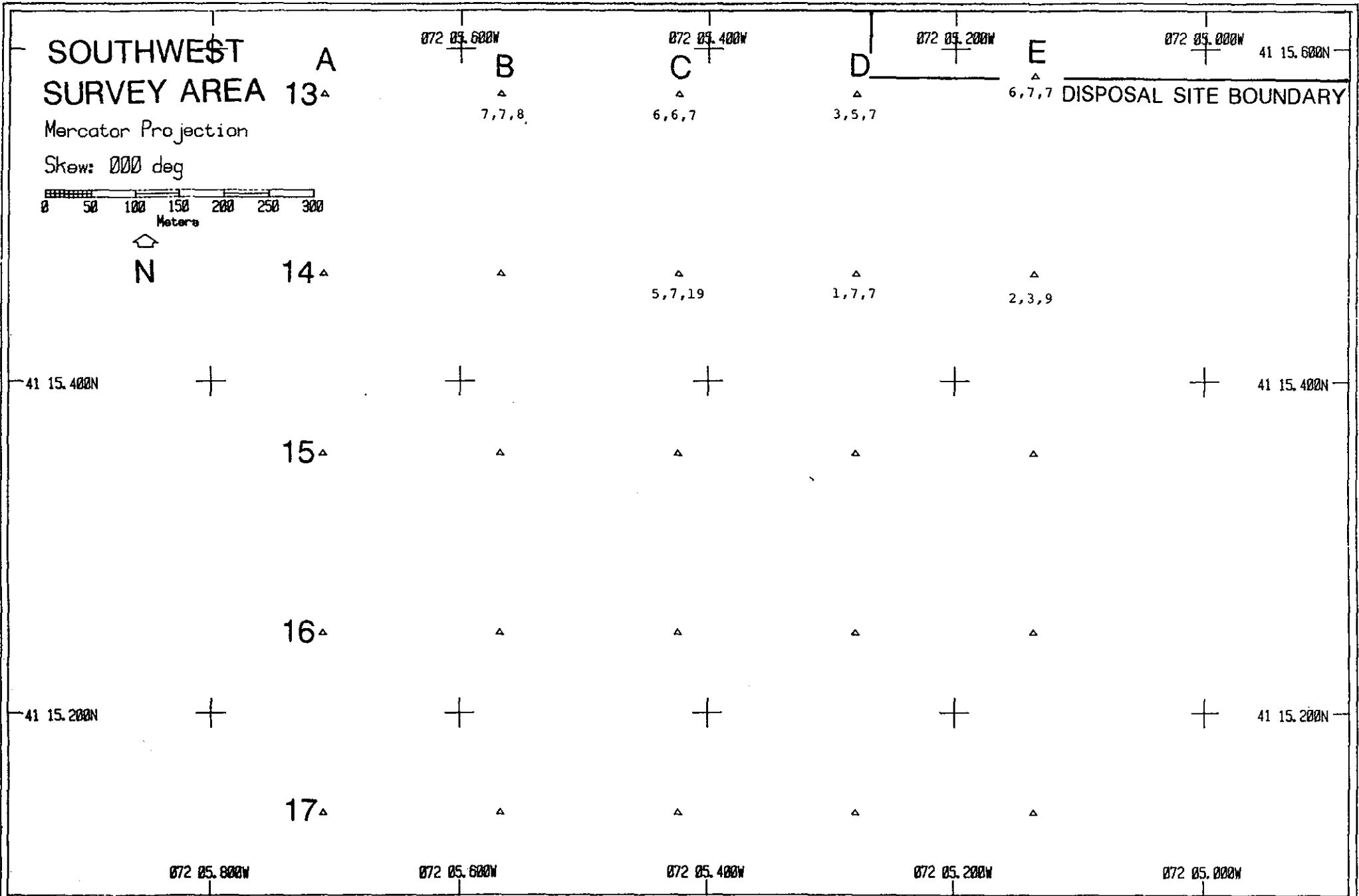
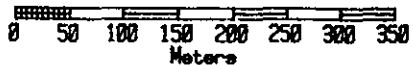

Figure 3-24. The distribution of OSI values at the Southwest survey area, August 1985. OSI values could not be calculated at the unlabeled stations.

NLON-85

Mercator Projection

Skew: 000 deg



41 16.250N



072 04.500W

072 04.250W

072 04.000W

072 03.750W

1

A
▲
 $\frac{3 - 2}{>4}$

B
▲
 $\frac{3 - 2}{>4}$

C
▲
 $\frac{4 - 3}{>4}$

D
▲
>4
Shell

2

▲
 $\frac{3 - 2}{>4}$

▲
2 - 1
Shell

▲
 $\frac{3 - 2}{>4}$

▲
 $\frac{3 - 2}{>4}$

3

▲
 $\frac{2 - 1}{>4}$

▲
 $\frac{3 - 2}{>4}$

▲
 $\frac{4 - 3}{>4}$

▲
4 - 3
Shell

4

▲
 $\frac{3 - 2}{>4}$

▲
 $\frac{3 - 2}{>4}$

▲
4 - 3
Shell

▲
3 - 2

072 04.750W

072 04.500W

072 04.250W

072 04.000W

072 03.750W

DISPOSAL SITE BOUNDARY

41 16.250N

41 16.000N

Figure 3-25. The distribution of grain-size major mode at the NLON-85 survey area, November 1985. Values are in phi units. The entire area consists of a thin sand layer (less than 1 to 3 cm) overlying a silty mud (>4 phi).

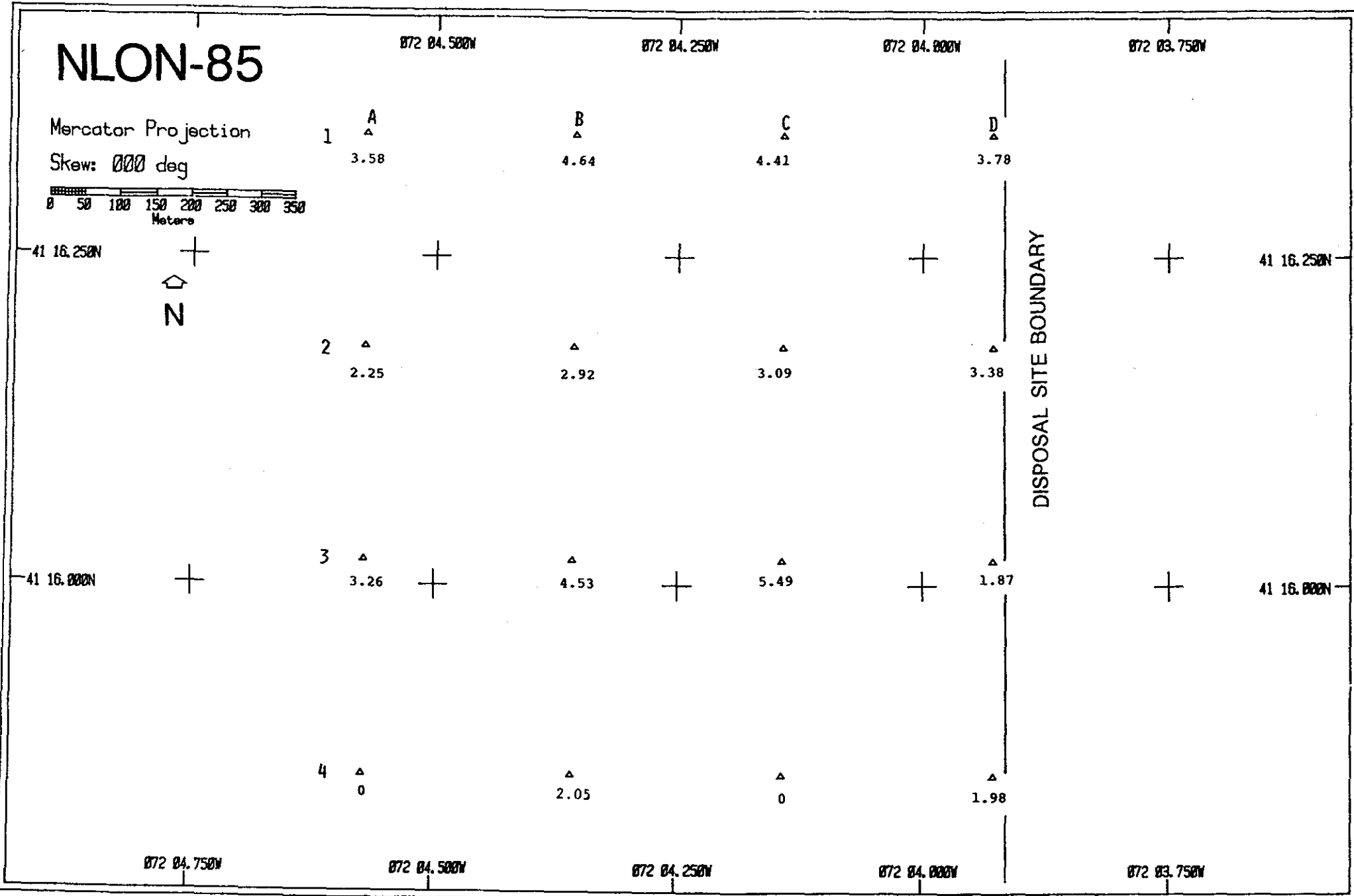

Figure 3-26. The distribution of mean apparent RPD depths at the NLON-85 survey area, November 1985.

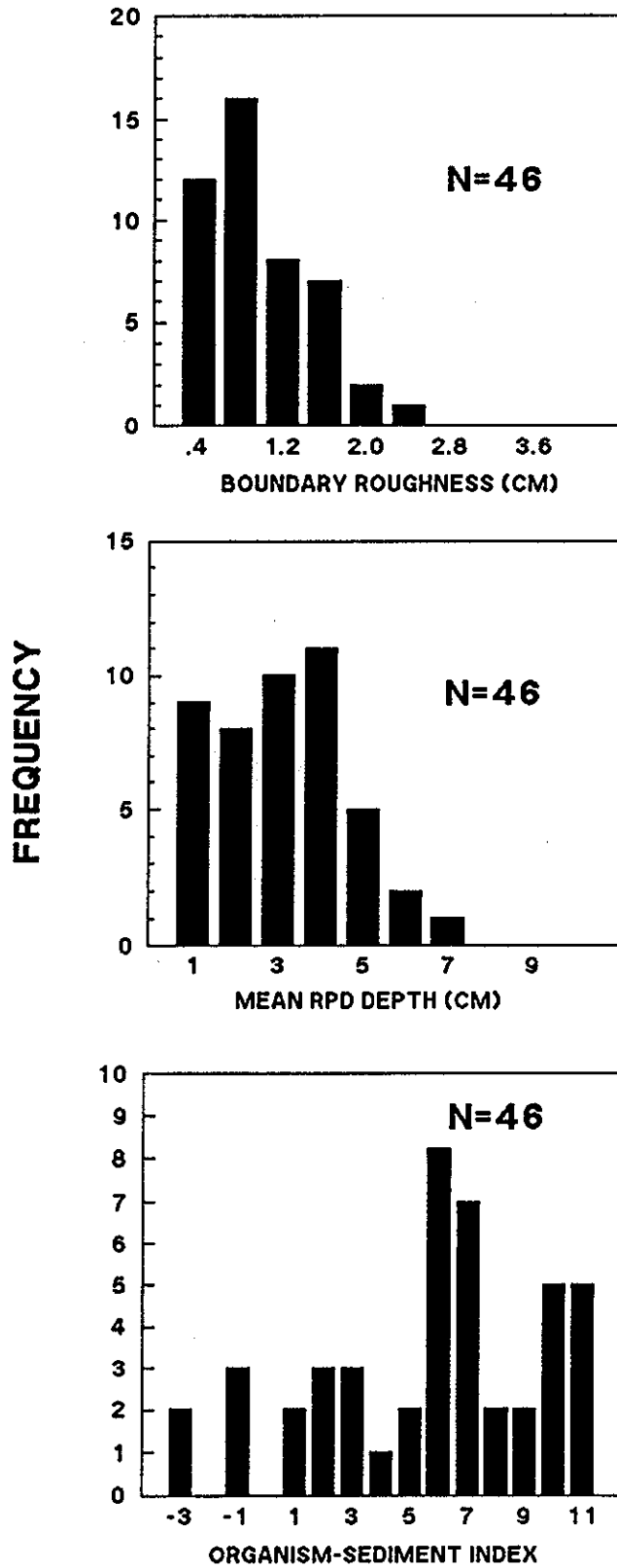

Figure 3-27. Frequency distributions of boundary roughness, RPD, and OSI values for the NLON-85 survey area, November 1985.

NLON-85

Mercator Projection

Skew: 000 deg

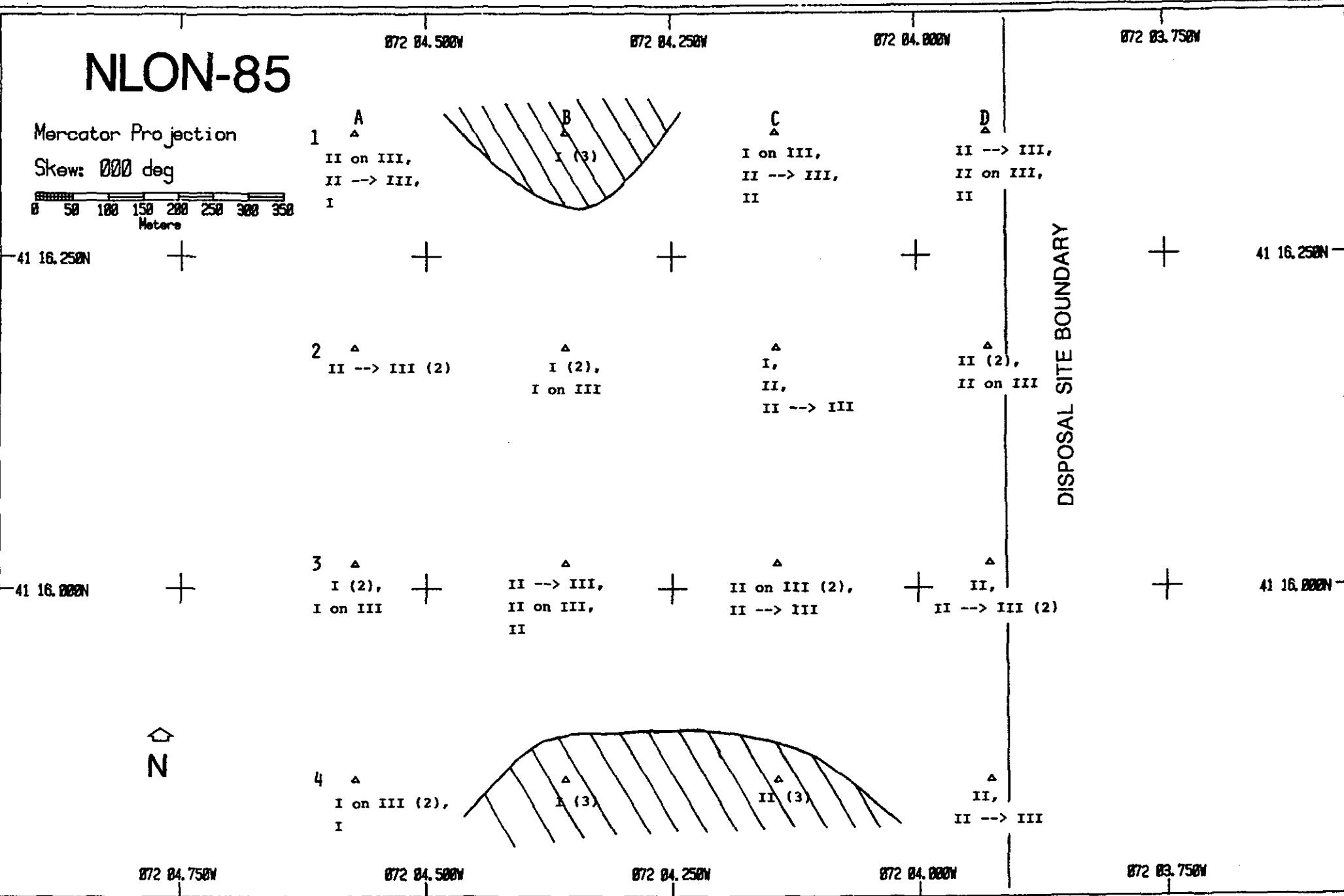
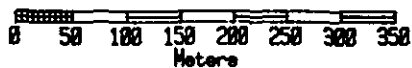

Figure 3-28. The distribution of infaunal successional seres at the NLON-85 survey area, November 1985. The hatched areas lacked evidence of high-order successional infauna (Stage III).

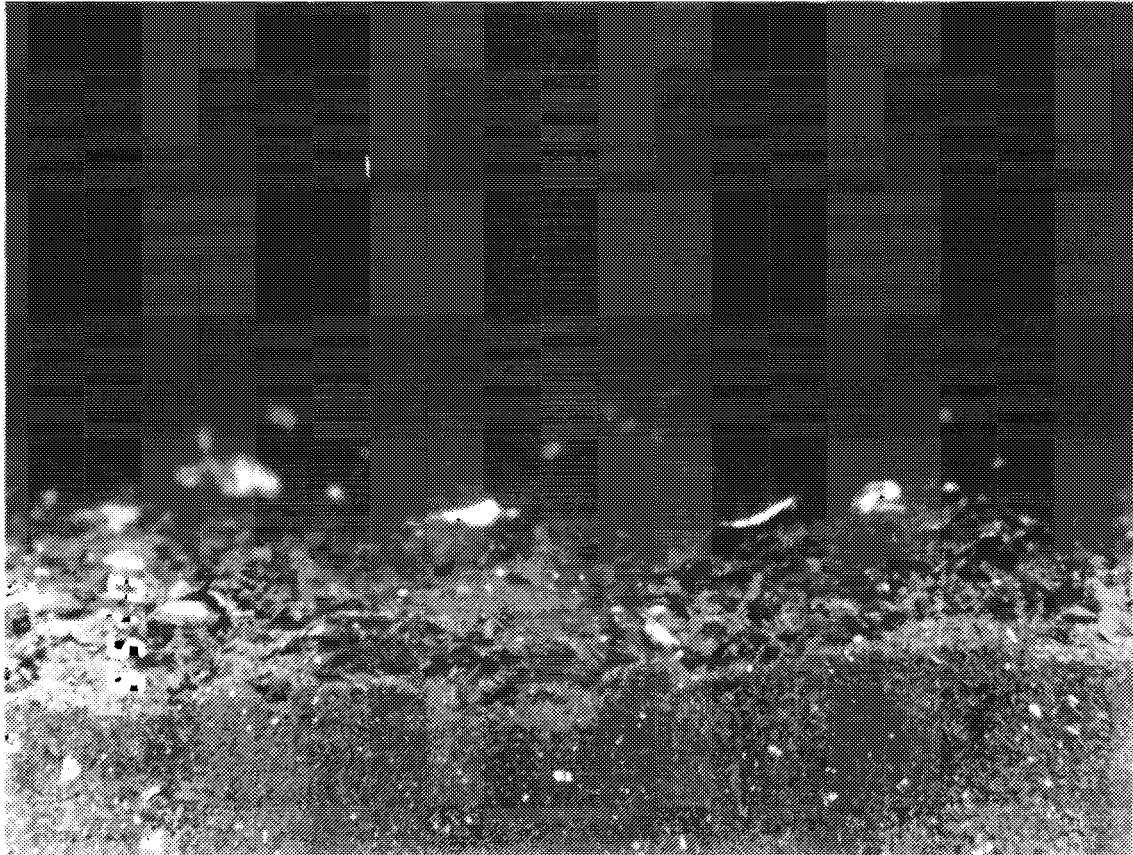

Figure 3-29. A REMOTS® photograph from NLON-85 station 4-C. High sediment oxygen demand and/or low oxygen supply water conditions are indicated by the lack of an apparent RPD. The retrograde Stage II amphipod mats appeared to be in various stages of decomposition and erosion. Scale = 1X.

NLON-85

Mercator Projection

Skew: 000 deg

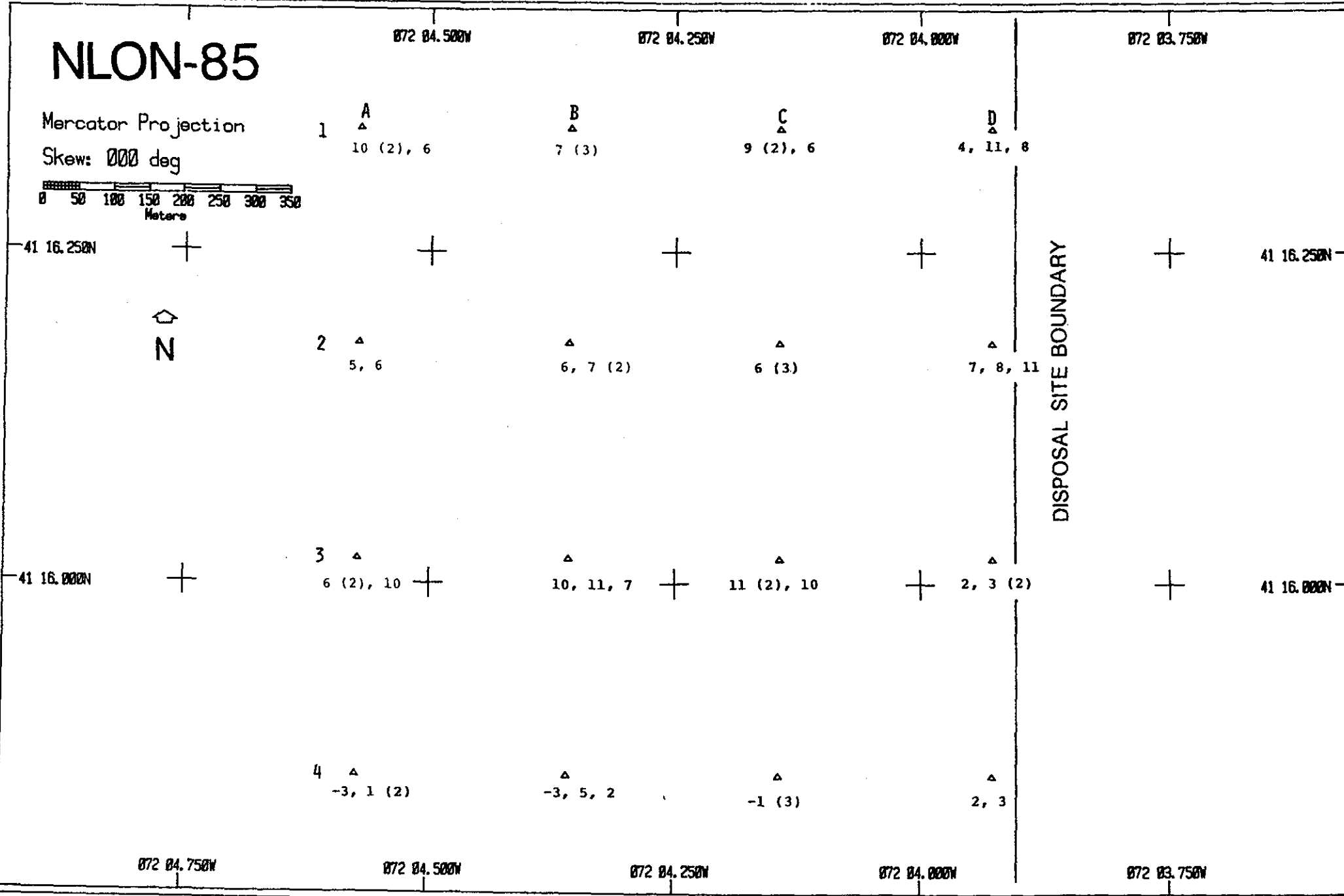
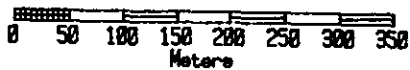

Figure 3-30. The distribution of OSI values at the NLON-85 survey area, November 1985.

NLON-85

Mercator Projection

Skew: 000 deg

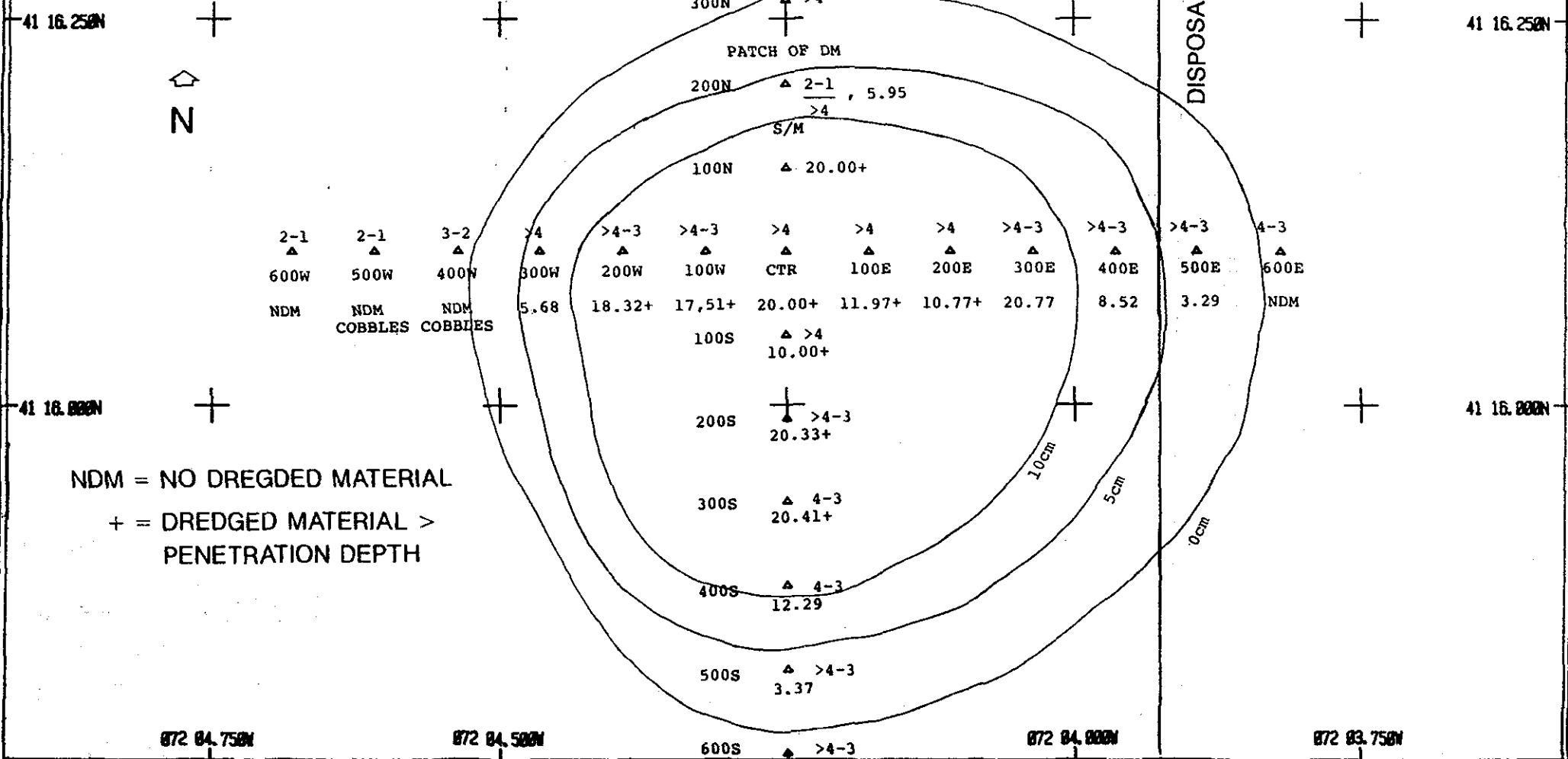
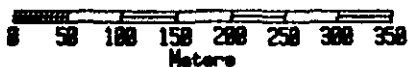

Figure 3-31. The distribution and thickness of dredged material at the NLON-85 survey area, January 1986. Grain size (phi units) is reported above the station label. The thickness values below the station label are in cm.

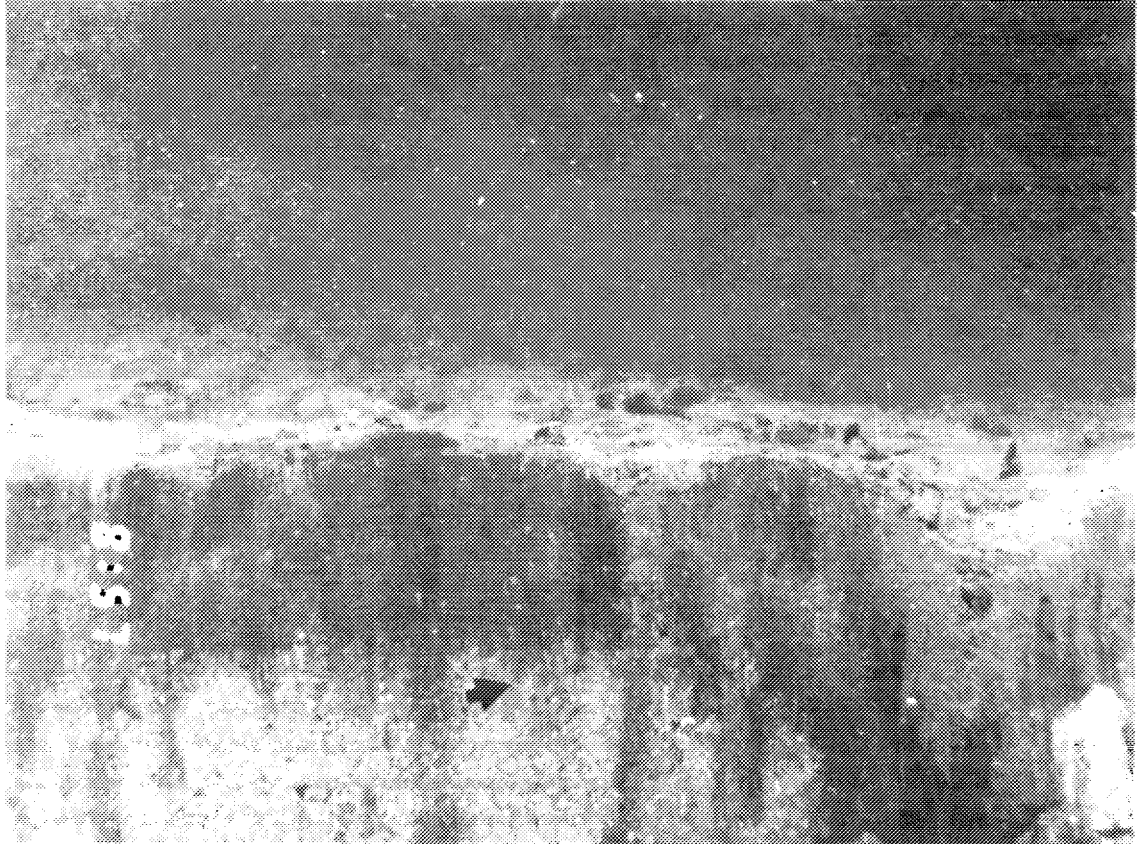

Figure 3-32. A REMOTS® photograph from NLON-85 station 500S showing a relatively thin dredged material layer (3.4 cm). The buried, high-reflectance, pre-disposal sediment-water interface is evident at depth (arrow). Scale = 1X.

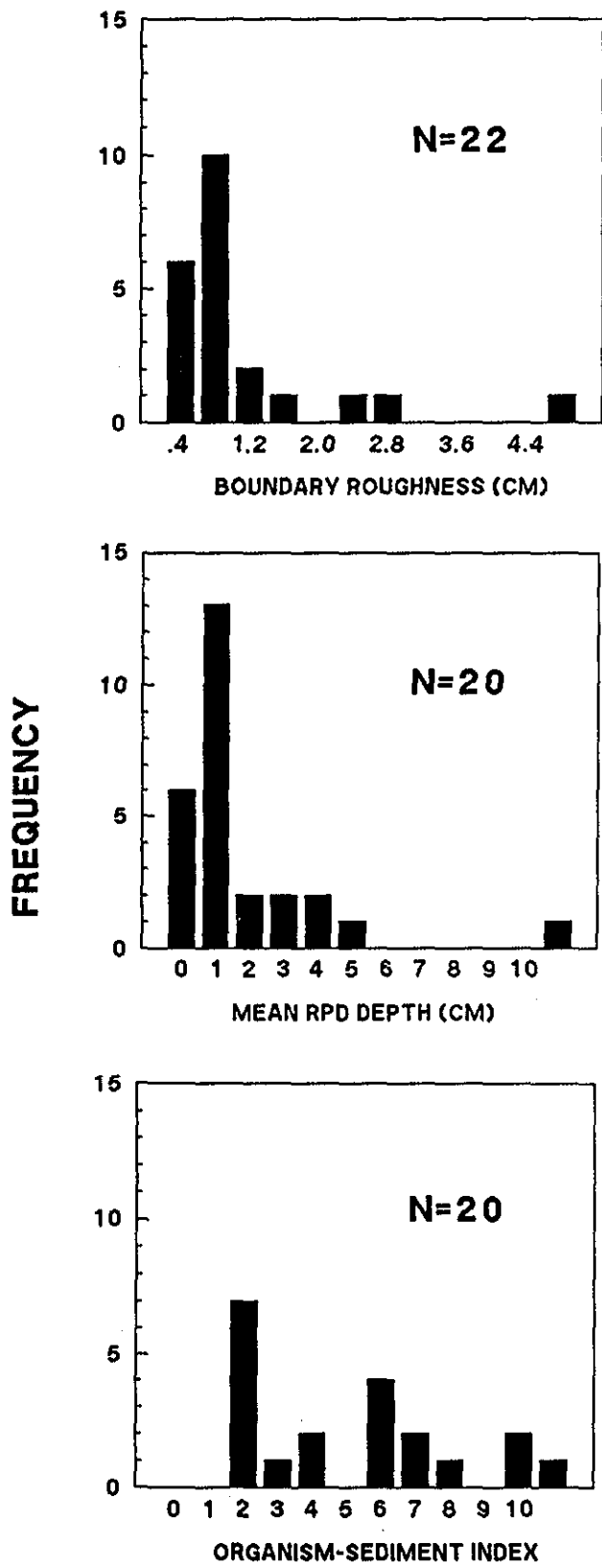

Figure 3-33. Frequency distributions for boundary roughness, RPD, and OSI values for the NLON-85 survey area, January 1986.

NLON-85

Mercator Projection

Skew: 000 deg

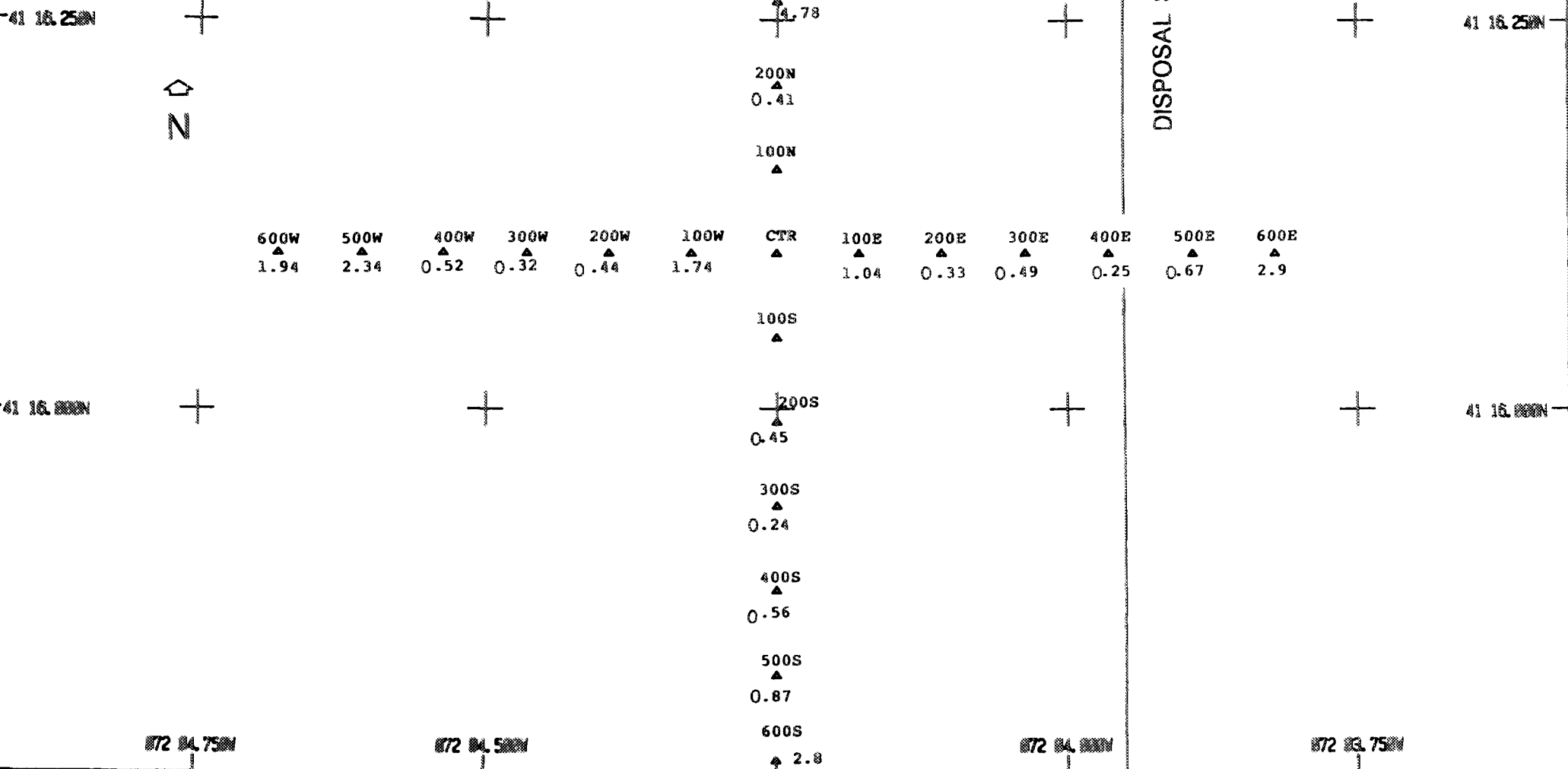

Figure 3-34. The distribution of mean apparent RPD depths at the NLON-85 survey area, January 1986. RPD depths could not be measured at unlabeled stations due to overpenetration of the camera prism.

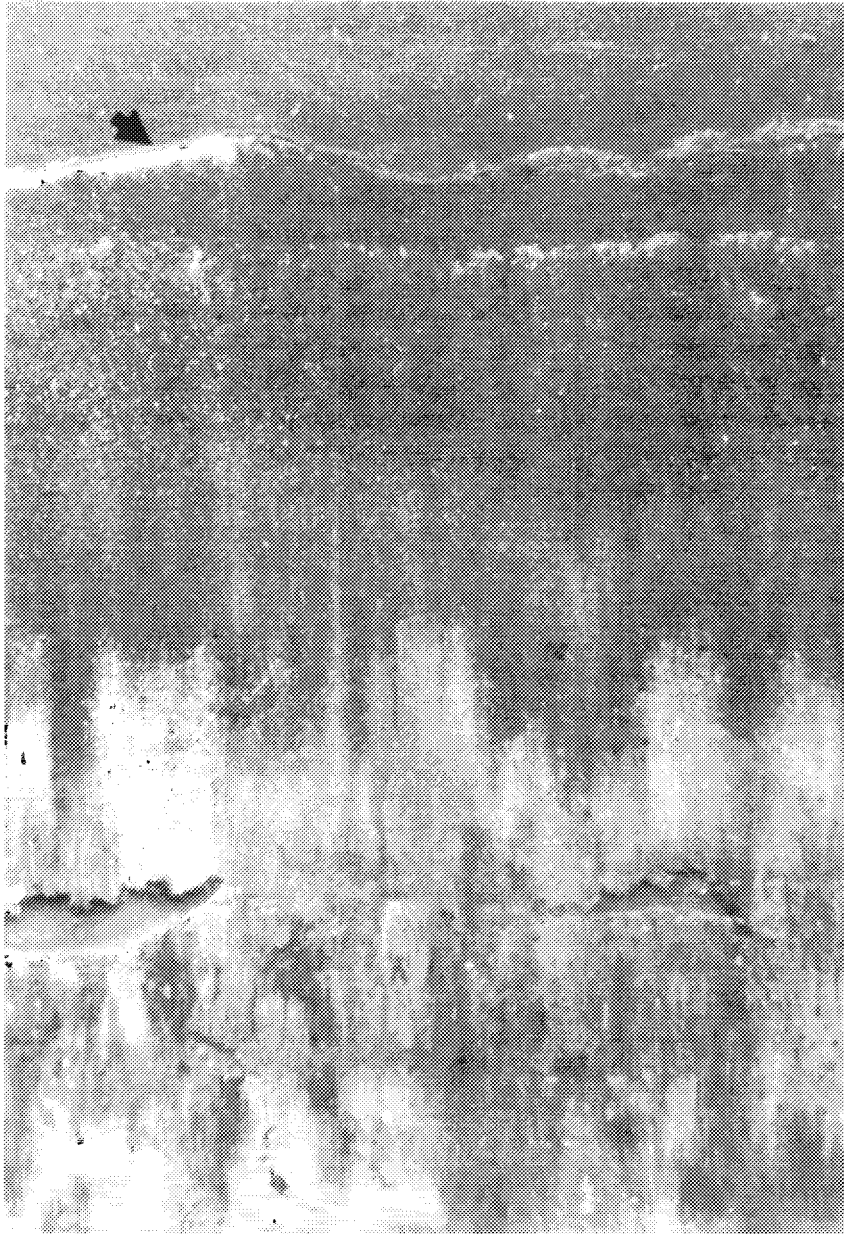
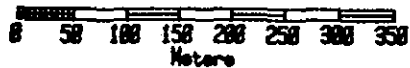

Figure 3-35. A REMOTS® photograph from NLON-85 station 400E showing a dredged material layer (low reflectance) and an extremely shallow RPD (arrow). Also note the feeding voids at depth. Scale = 1X.

NLON-85

Mercator Projection

Skew: 000 deg



072 04. 500V

600N
II on III

072 04. 000V

072 03. 750V

41 16. 250N



41 16. 250N

600W 500W 400W 300W 200W 100W CTR 100E 200E 300E 400E 500E 600E
I on III Ind I I I I I I I I I on III I on III II II

DISPOSAL SITE BOUNDARY

41 16. 000N

41 16. 000N

IND = INDETERMINATE

200N
I

100N
I

300N
II on III

100S
I

200S
I

300S
I on III

400S
I

500S
II --> III

600S
II

072 04. 750V

072 04. 500V

072 04. 000V

072 03. 750V

Figure 3-36. The distribution of infaunal successional seres at the NLON-85 survey area, January 1986. Hatched areas indicate the lack of Stage III seres.

NLON-85

Mercator Projection

Skew: 000 deg

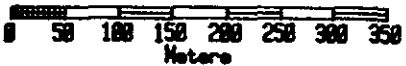

41 16.250N



600W	500W	400W	300W	200W	100W	CTR	100E	200E	300E	400E	500E	600E
▲	▲	▲	▲	▲	▲	▲	▲	▲	▲	▲	▲	▲
8	Ind.	2	2	2	4		3	2	6	6	4	7

41 16.000N

IND = INDETERMINATE

872 84.750W

872 84.500W

872 84.000W

872 83.750W

600N
▲
10
500N
▲
10
400N
▲
7
300N
▲
11
200N
▲
2
100N
▲
100S
▲
200S
▲
2
300S
▲
6
400S
▲
2
500S
▲
6
600S
▲
Ind.

872 84.000W

872 83.750W

DISPOSAL SITE BOUNDARY

41 16.250N

41 16.000N

Figure 3-37. The distribution of OSI values at the NLON-85 survey area, January 1986.

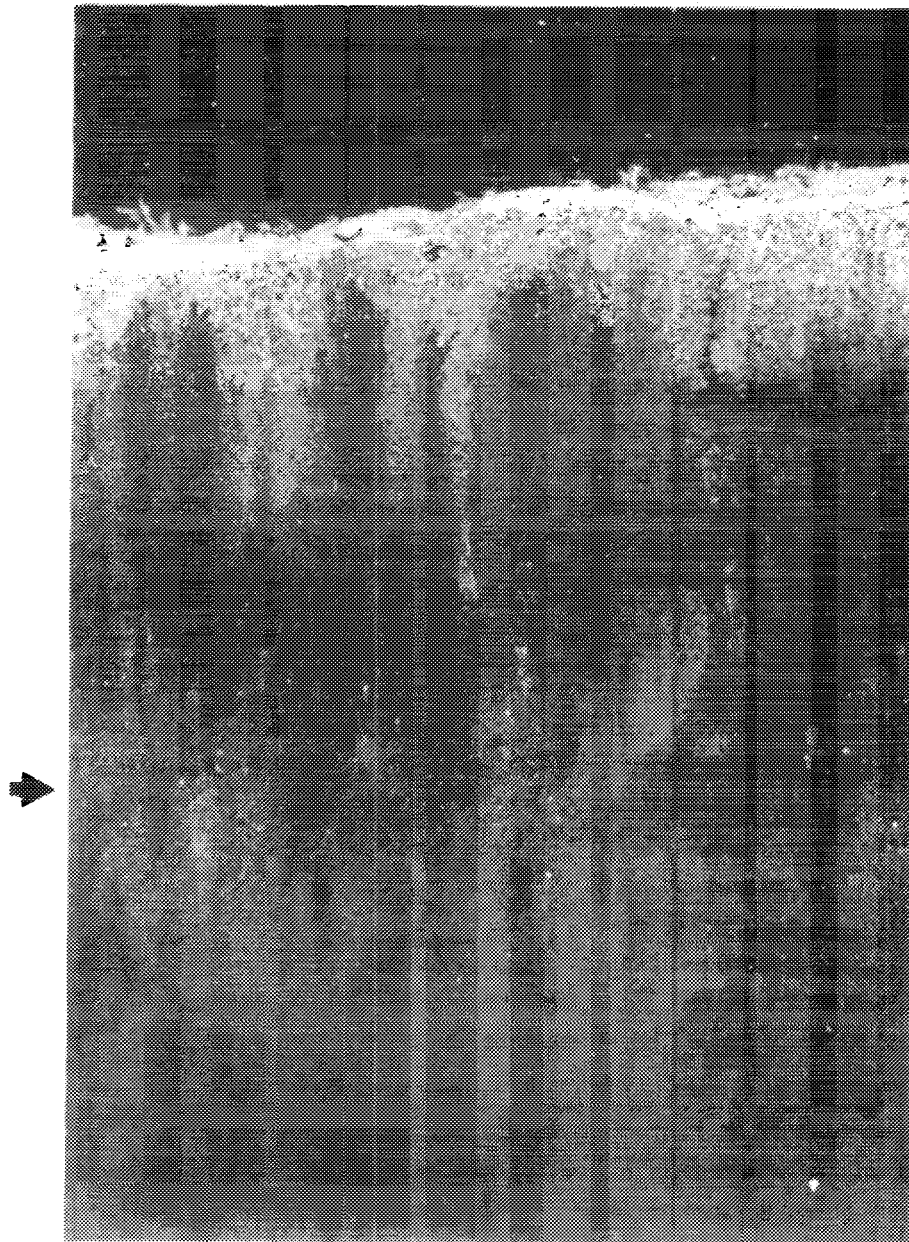

Figure 3-39. A REMOTS® photograph from NLON-85 station 300W showing a distinct dredged material layer approximately 8 cm thick. The arrow indicates the location of the pre-disposal interface inferred from the relatively high-reflectance of the buried RPD layer. Scale = 1X.

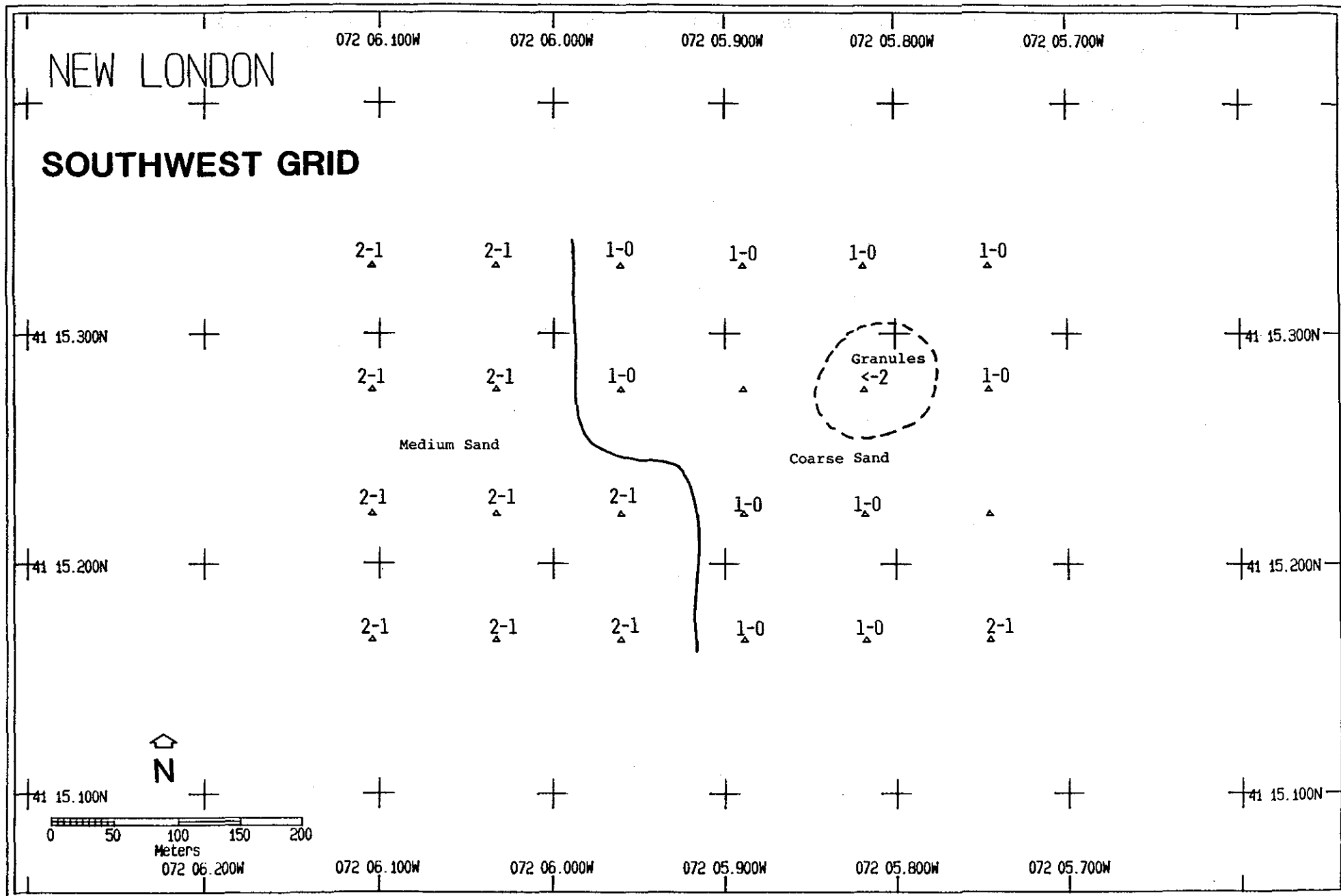

Figure 3-41. The distribution of grain-size major mode at the Southwest grid, July 1986. Values indicated are in phi units. No data were obtained at unlabeled stations. The contour separates areas of medium and coarse sand.

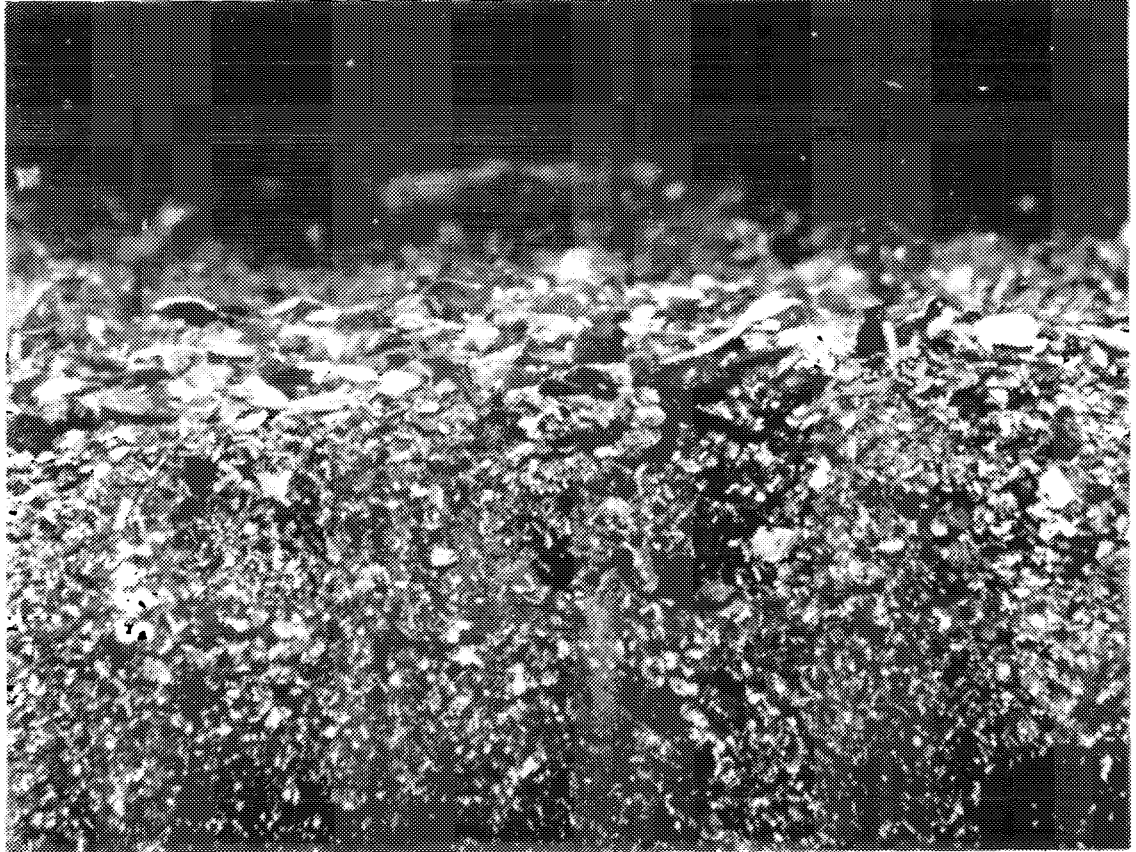

Figure 3-42. A REMOTS® photograph from the southwest reconnaissance grid showing a bottom consisting of coarse sand and shell fragments. Scale = 1X.

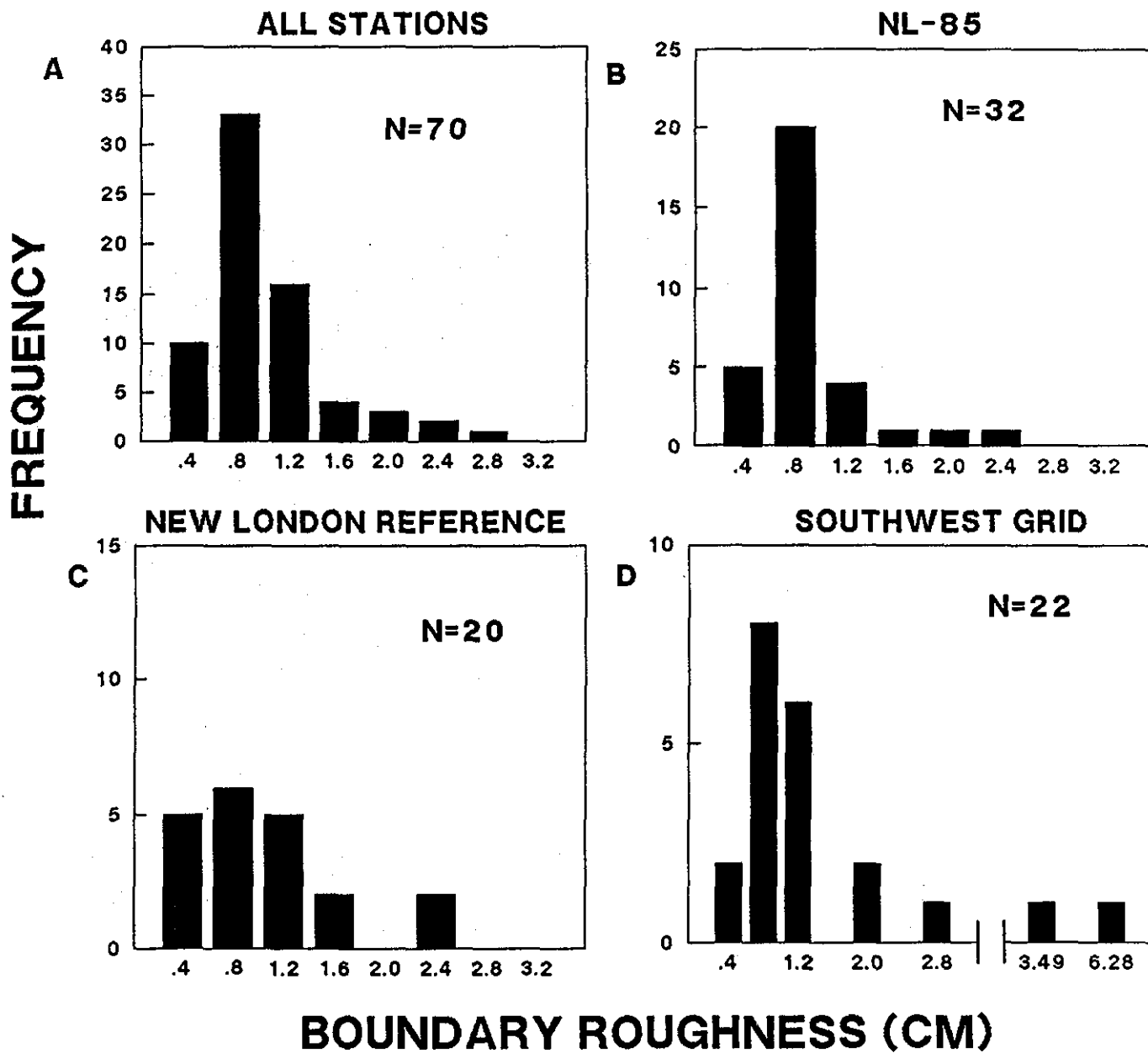

Figure 3-43. Frequency distributions of boundary roughness values for all stations in the New London Disposal Site (A), for the NL-85 mound (B), for the Reference station (C), and for the Southwest grid (D), July 1986.

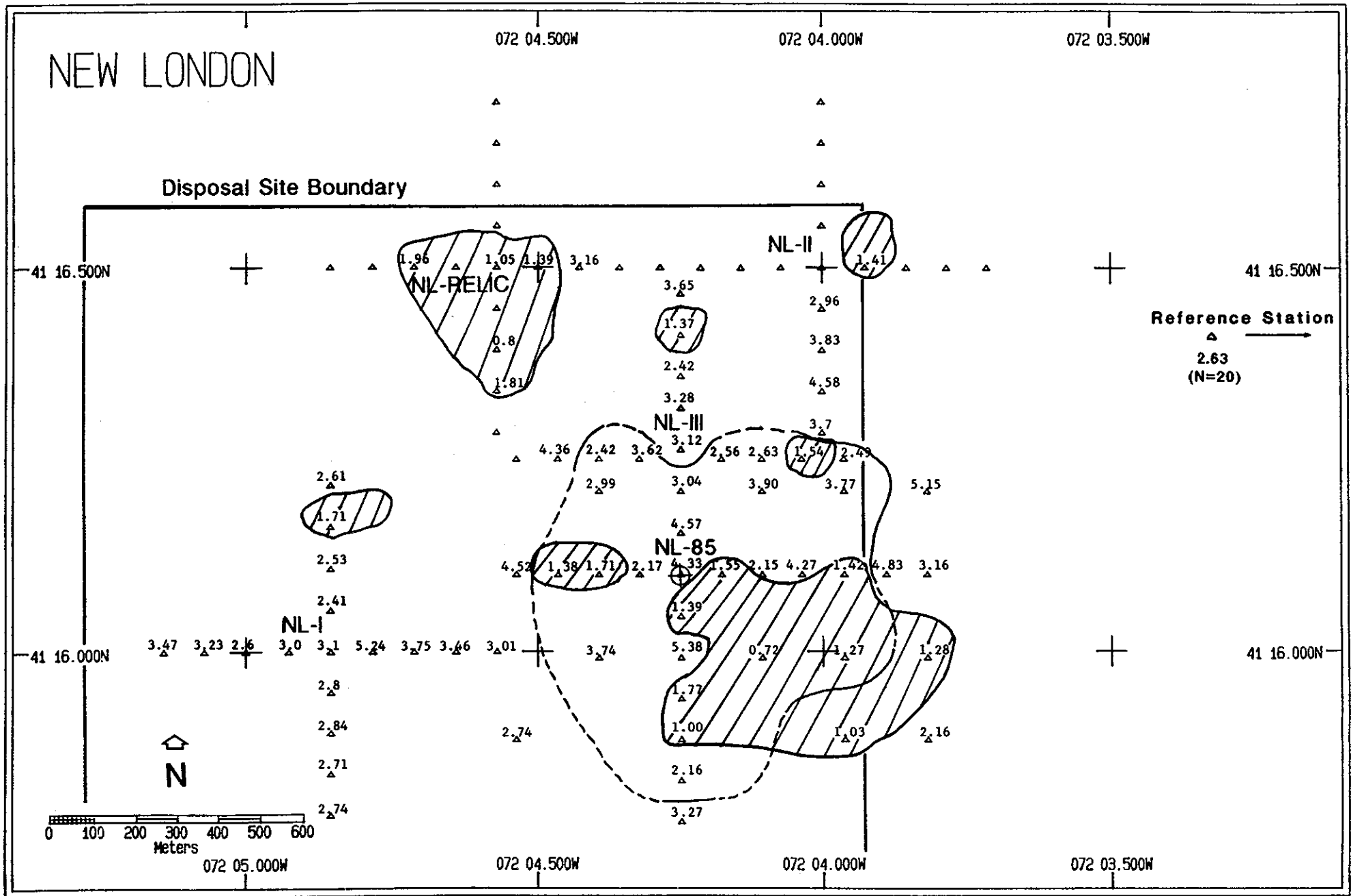

Figure 3-44. The distribution of mean apparent RPD depths at the New London Disposal Site, July 1986. The hatching shows regions where RPD depths were less than 2.00 cm. The NL-85 mound is indicated by the dashed contour. No data were obtained at unlabeled stations.

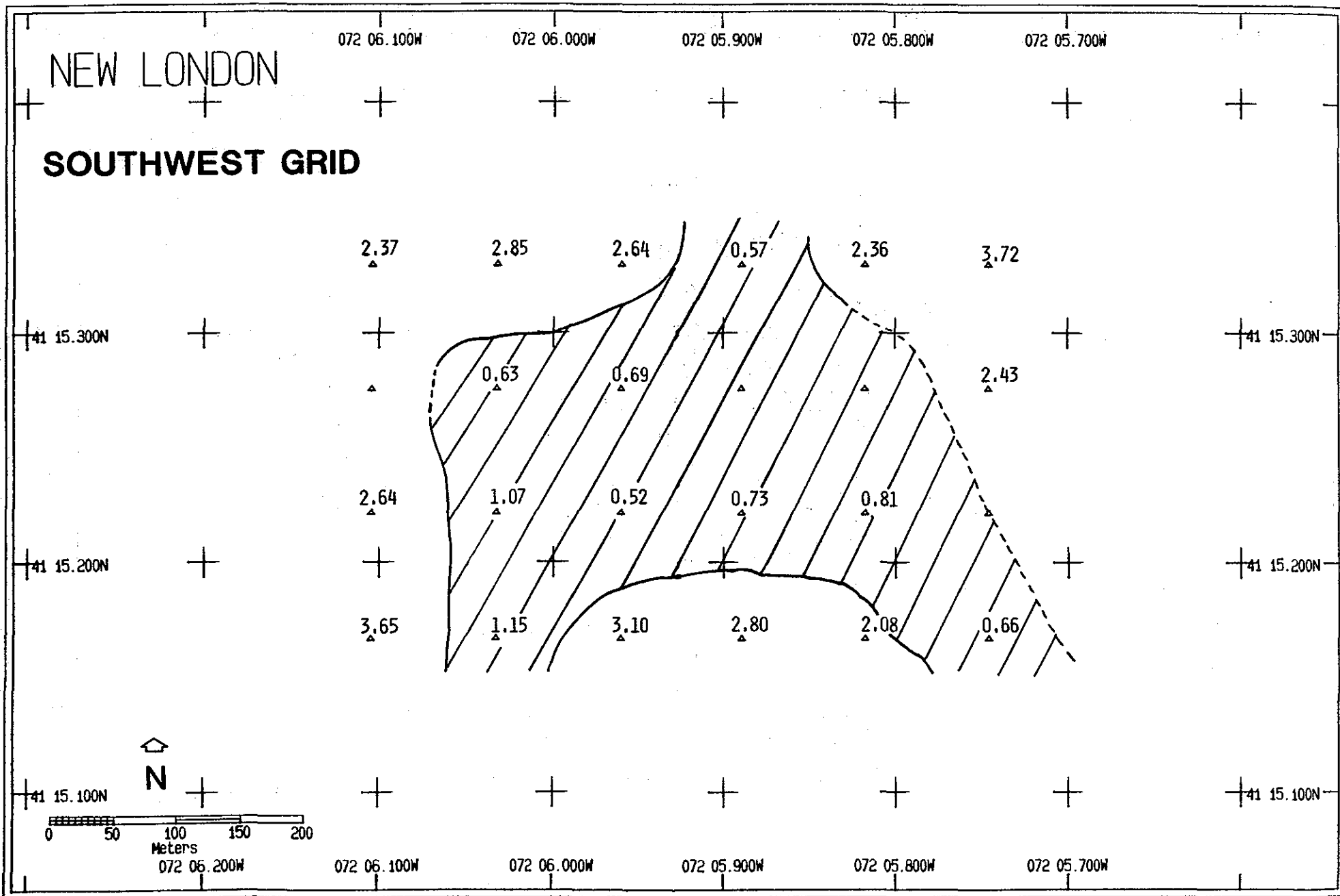

Figure 3-45. The distribution of mean apparent RPD depths at the Southwest grid, July 1986. The hatching shows regions where RPD depths were less than 2.00 cm. No data were obtained at unlabeled stations.

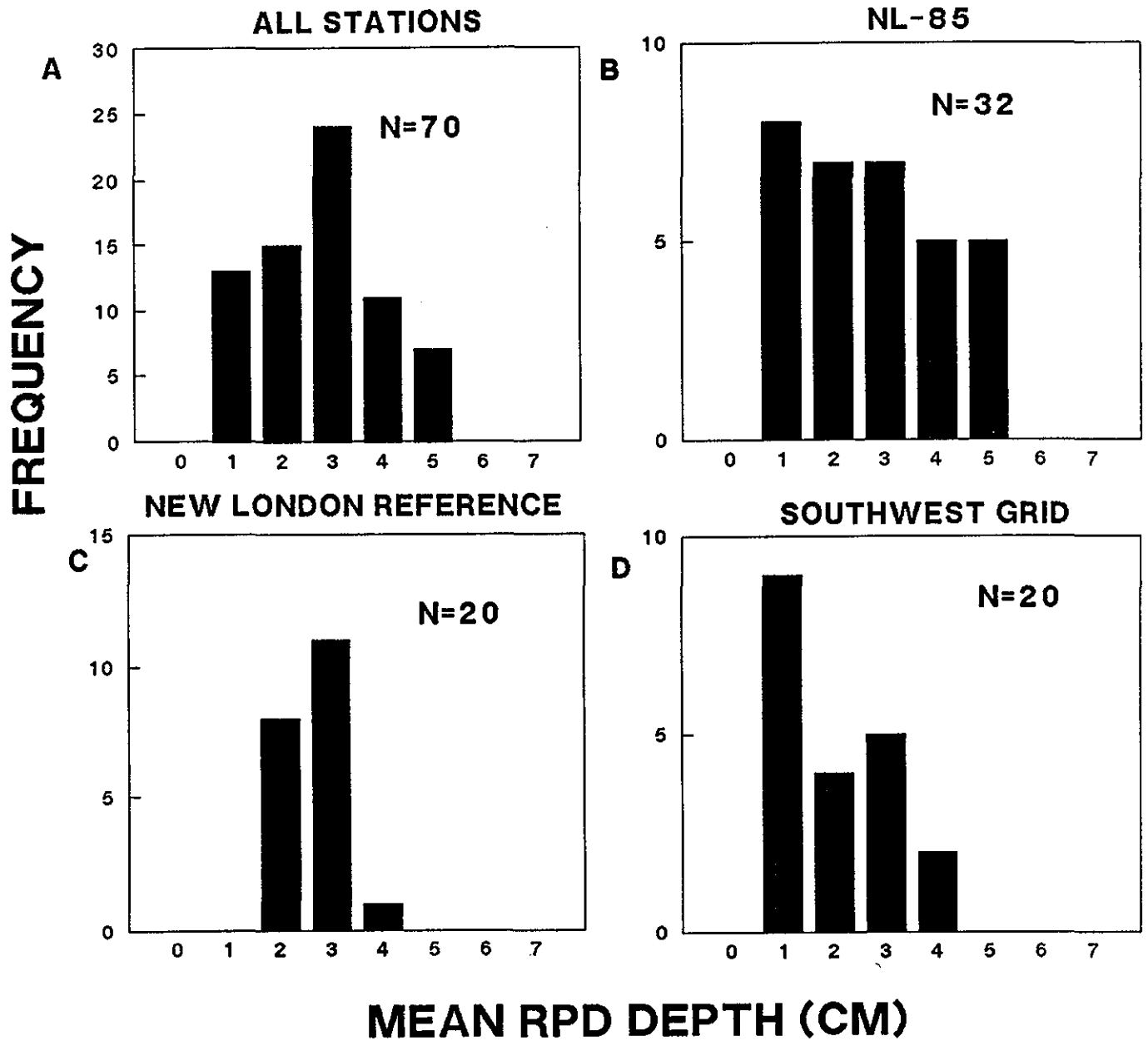

Figure 3-46. Frequency distributions of mean apparent RPD depths for all stations in the New London Disposal Site (A), for the NL-85 mound (B), for the Reference station (C), and for the Southwest grid (D), July 1986.

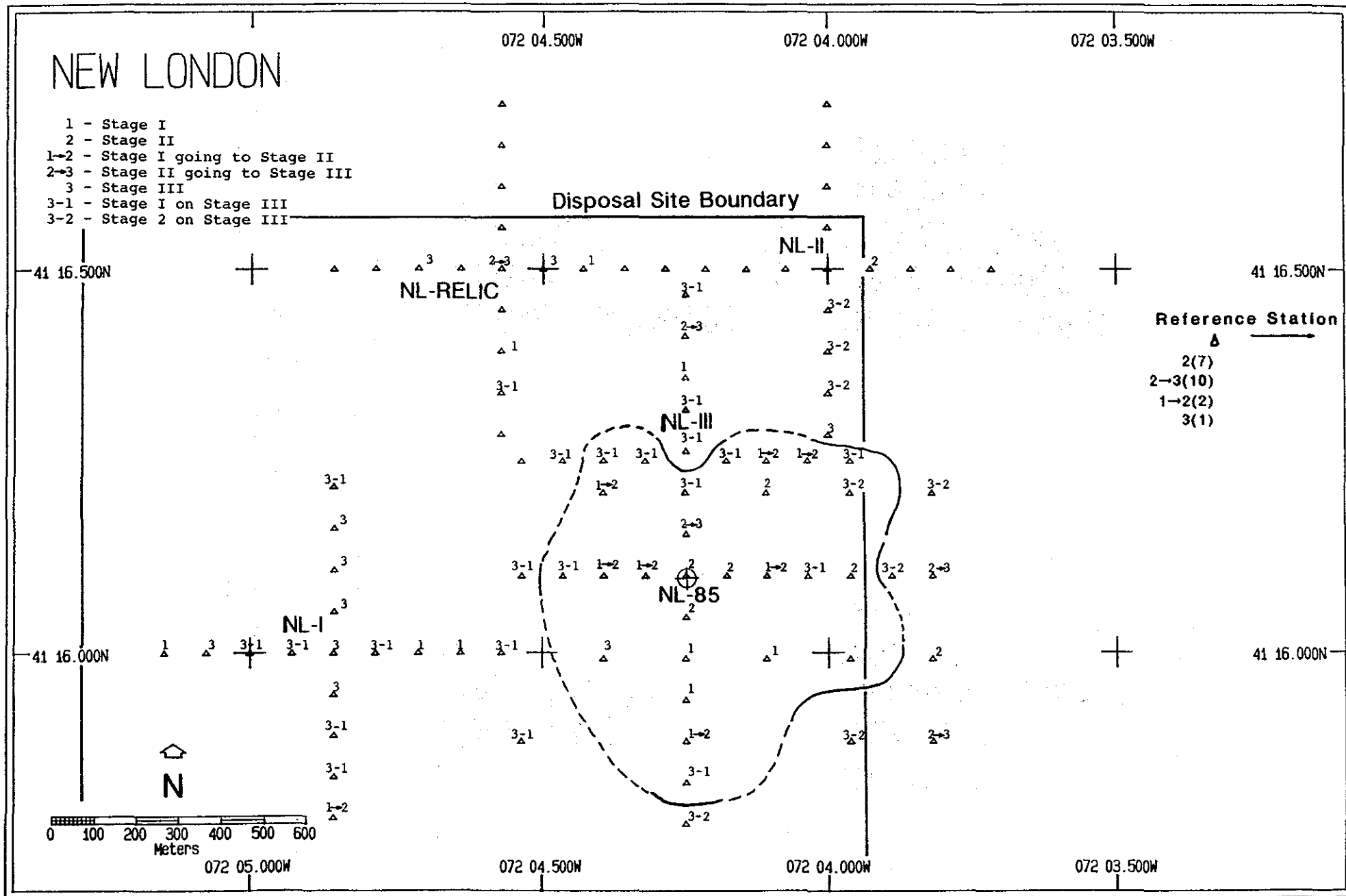

Figure 3-47. The distribution of successional stages at the New London Disposal Site, July 1986. The contour shows the extent of the NL-85 disposal mound. No data were obtained at unlabeled stations. At the reference station, the number of replicates showing a particular successional stage is indicated in parentheses.

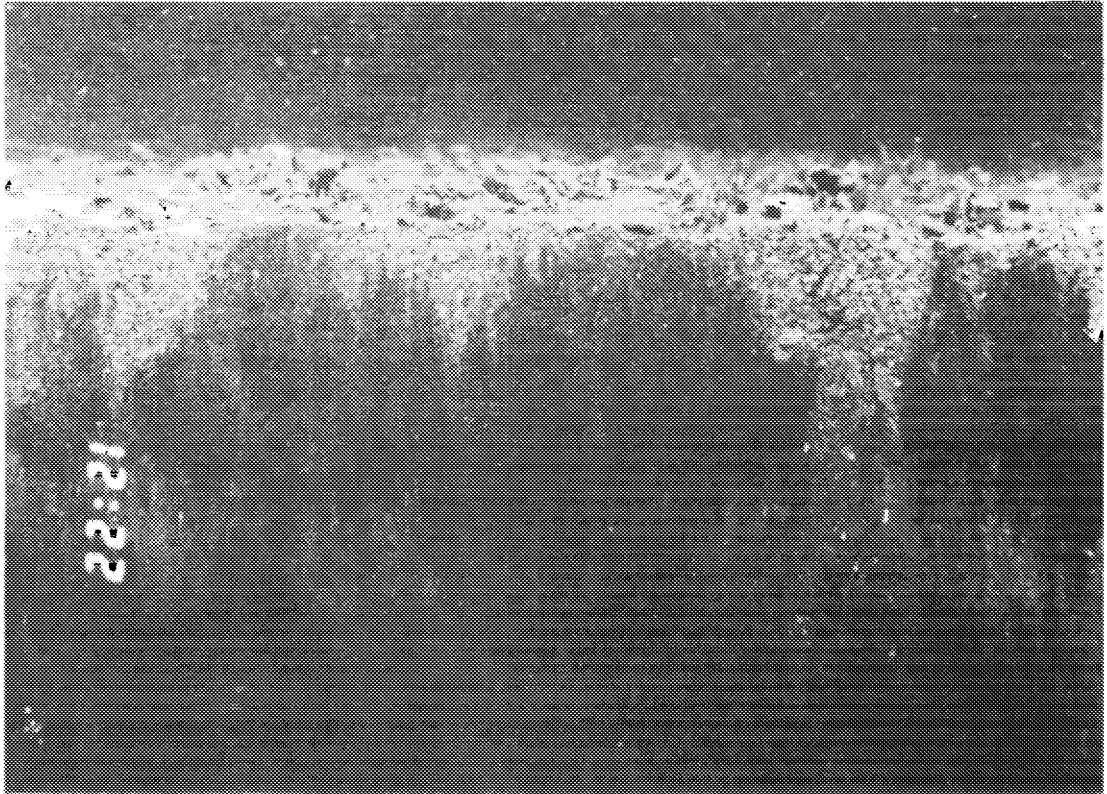

Figure 3-48 A REMOTS[®] photograph from NLON-85 station 400E showing a well-developed Stage II assemblage characterized by tube-dwelling amphipods. Scale = 1X.



Figure 3-49. A REMOTS® photograph from the New London Reference Station showing a disturbed surface amphipod tube mat. Hydroids are also evident at the sediment-water interface. This photograph represents a Stage II going to a Stage III successional status. Scale = 1X.

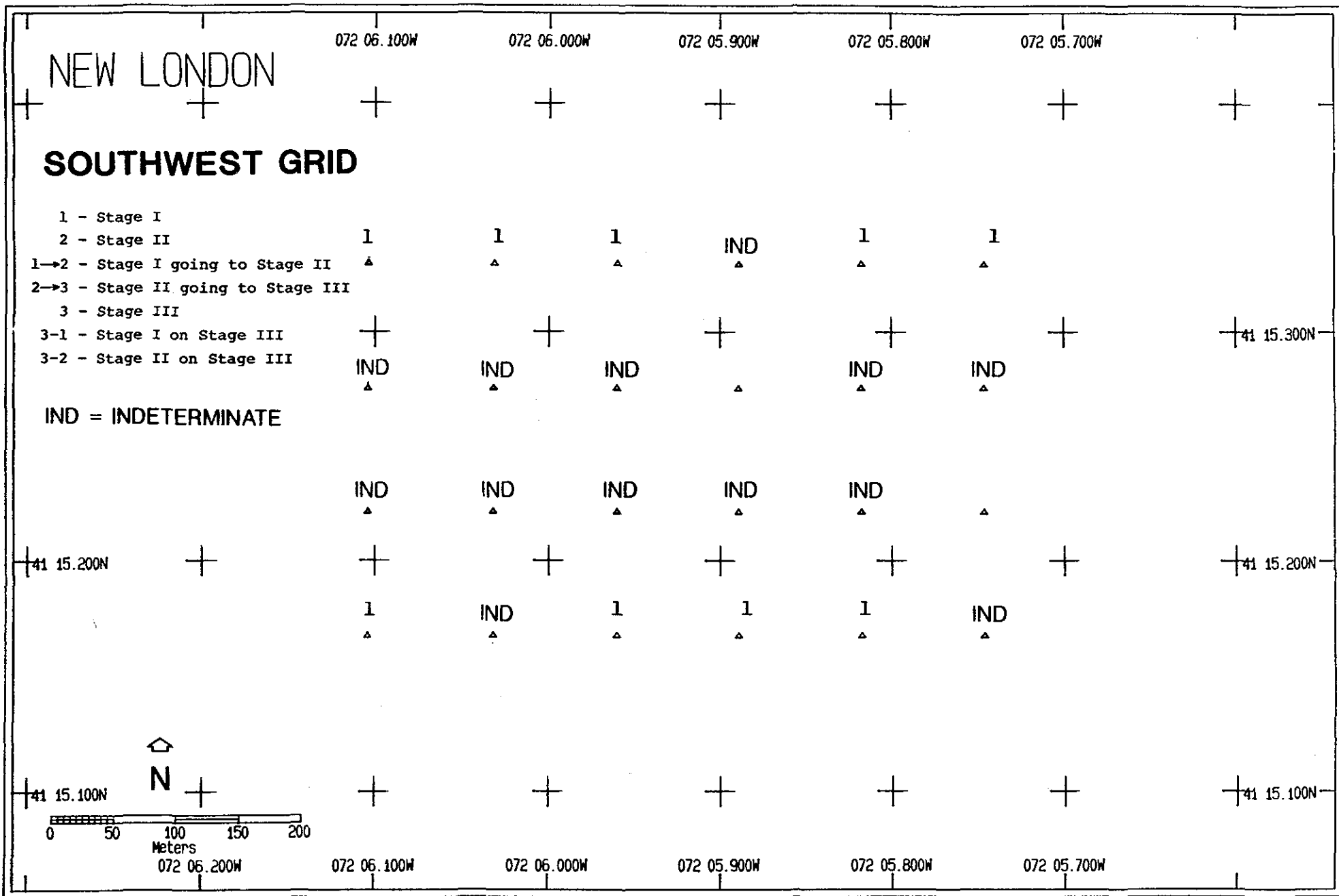

Figure 3-50. The distribution of successional stages at the Southwest grid, July 1986. No data were obtained at unlabeled stations.

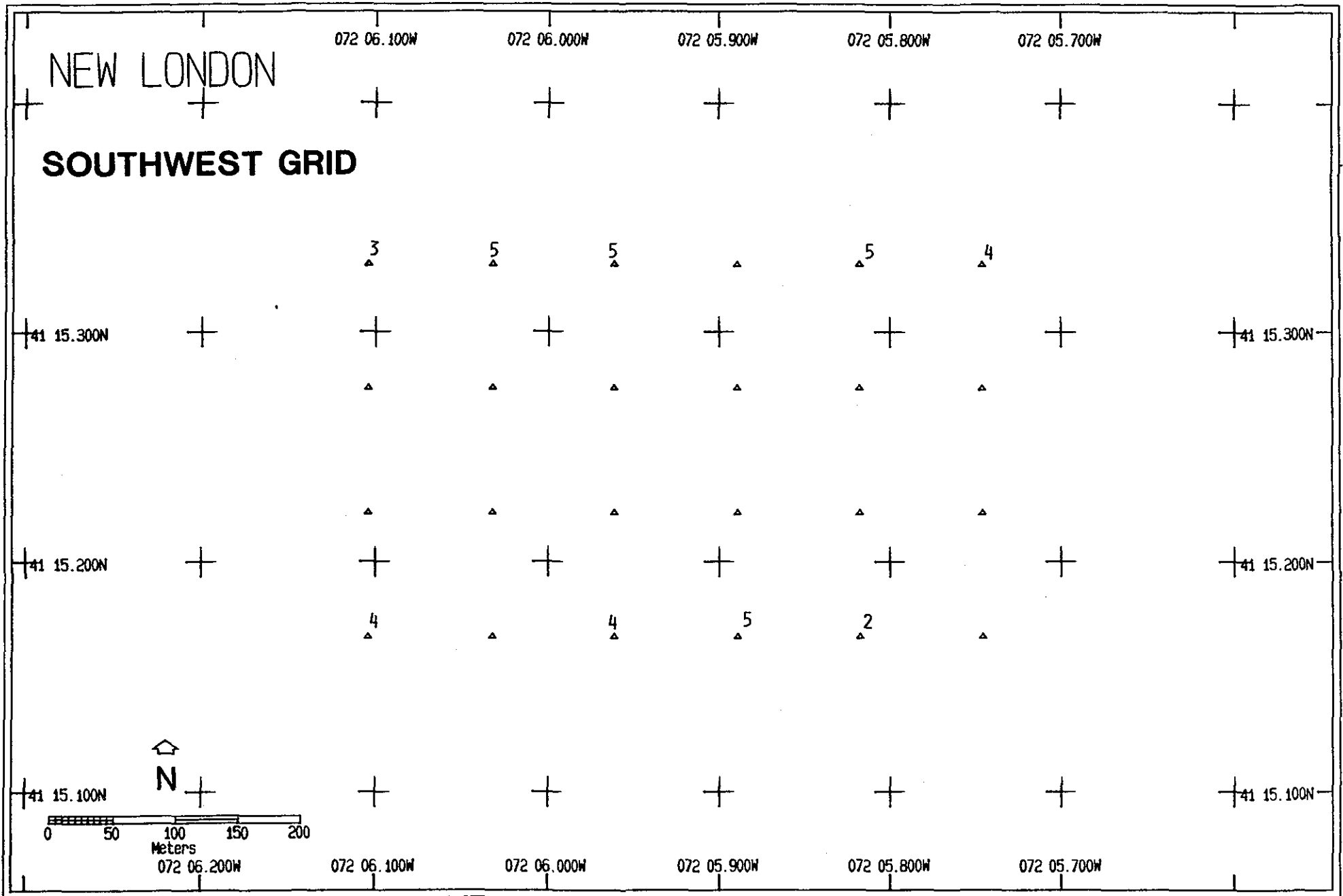

Figure 3-52. The distribution of OSI values at the Southwest grid, July 1986. The OSI value could not be calculated at unlabeled stations.

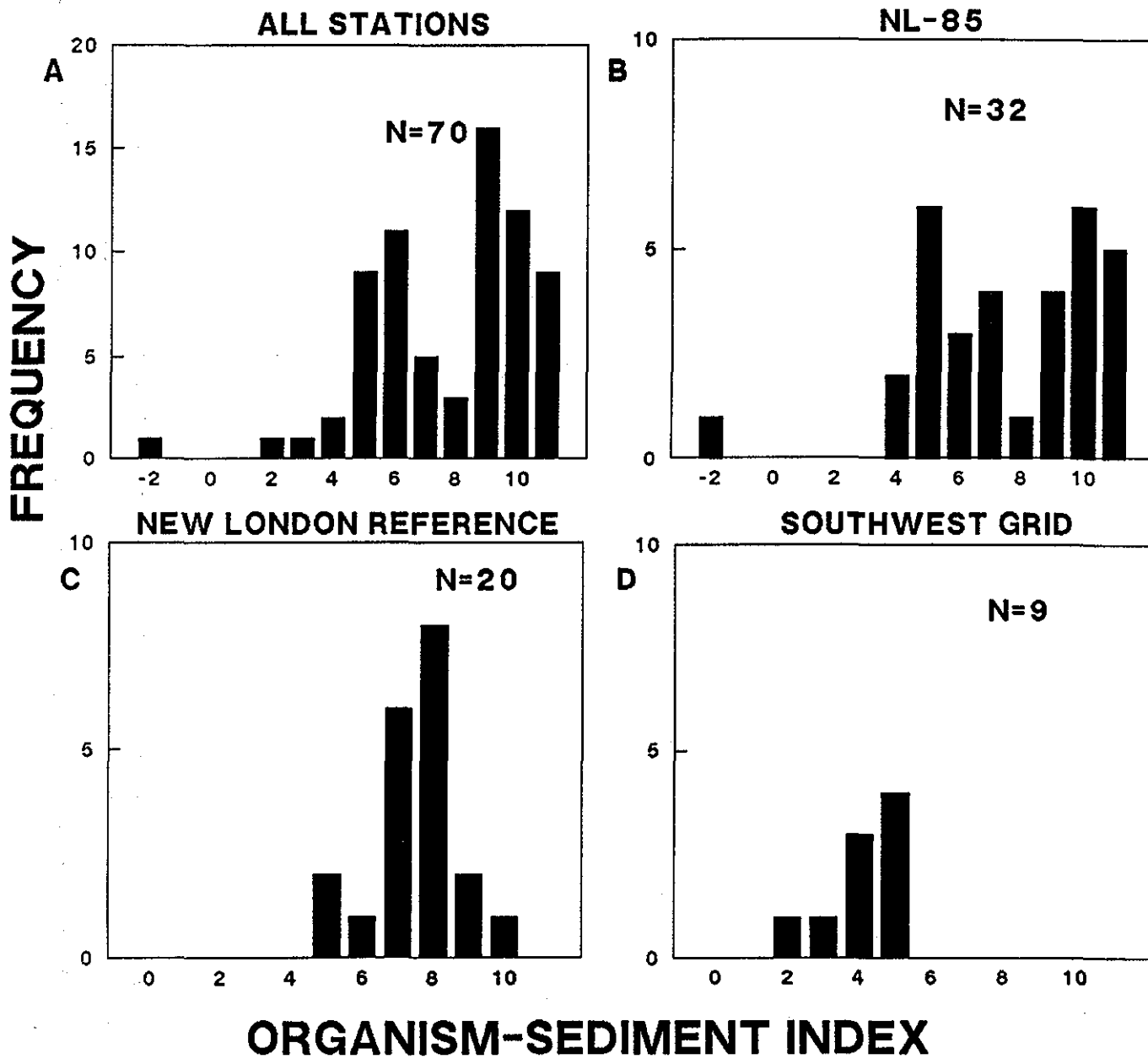

Figure 3-53. Frequency distributions of OSI values for all stations in the New London Disposal Site (A), for the NL-85 mound (B), for the Reference station (C), and for the Southwest grid (D), July 1986.

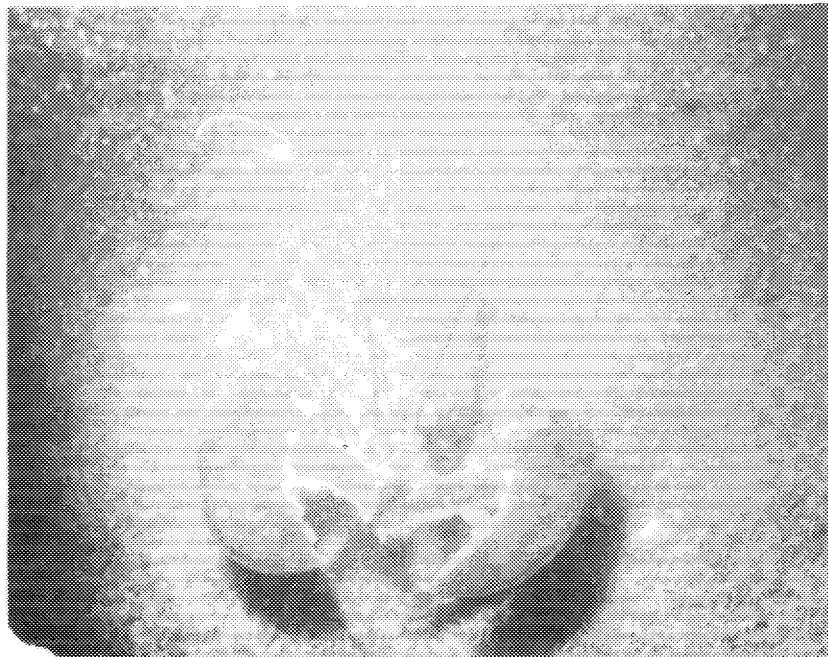

Figure 3-54. A lobster out of its burrow at the disposal mound.

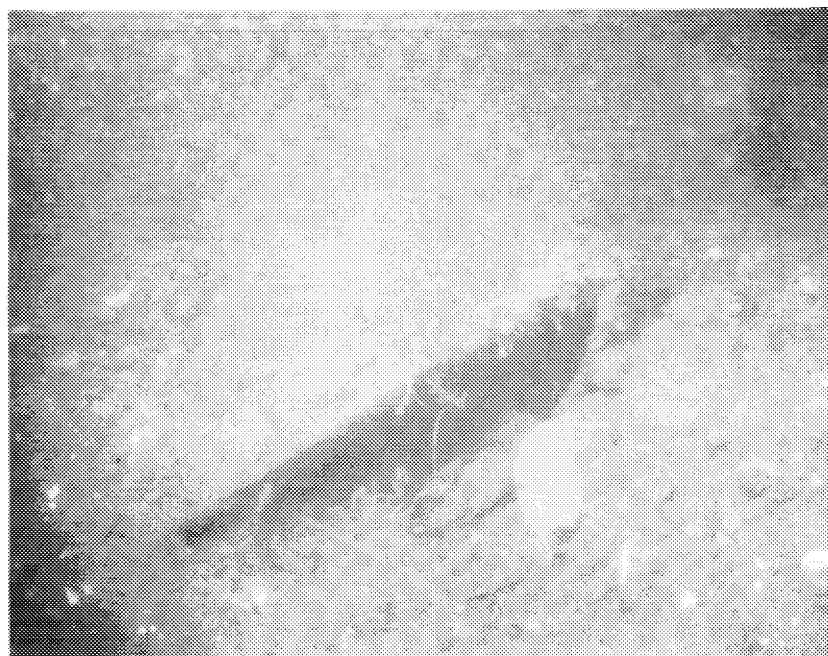

Figure 3-55. A lobster burrowed under debris.

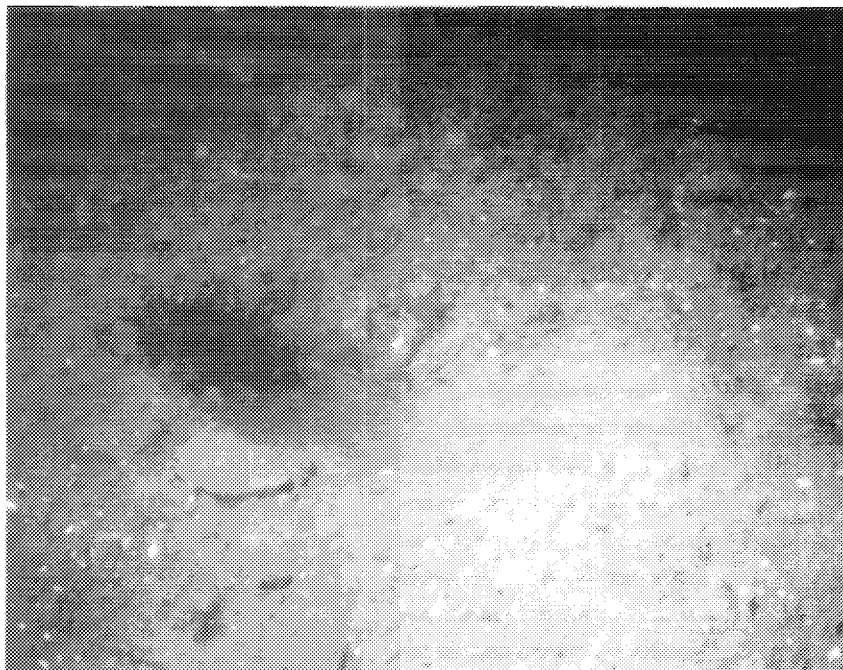

Figure 3-56. A typical burrow excavated into the mud of a slight topographic rise.

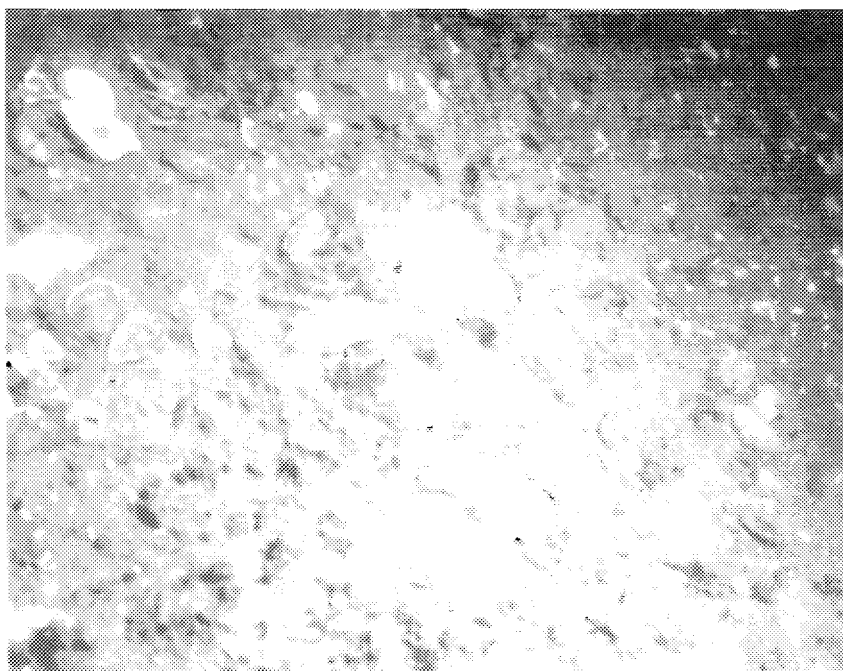

Figure 3-57. Shell hash and amphipod tube mat surface conditions in the northeast section of the New London Disposal Site.

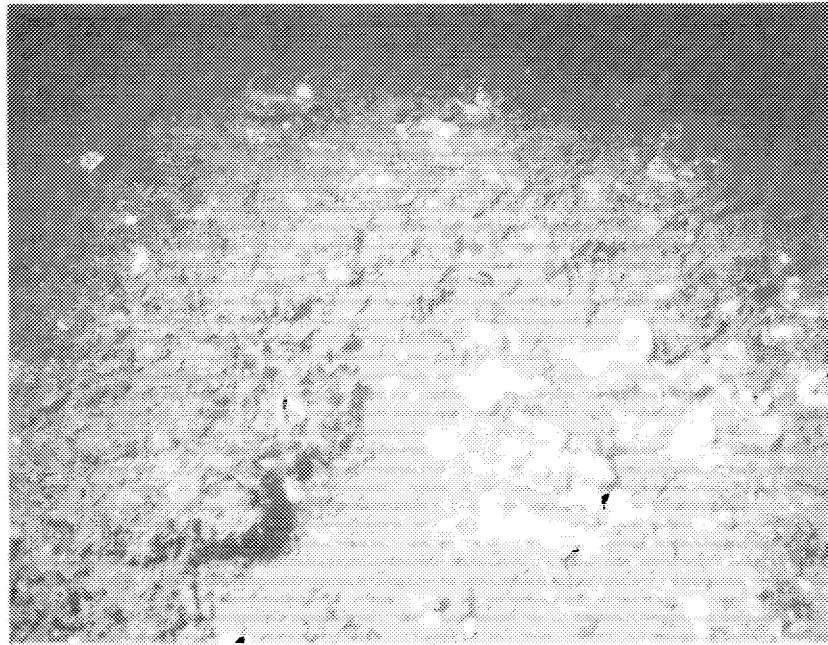

Figure 3-58. A crustacean foraging excavation.



Figure 3-59. Typical surface conditions containing amphipod tubes, sparse shell hash, and an occasional hydroid.



Figure 3-60. Winter flounder swimming over amphipod tube mat.

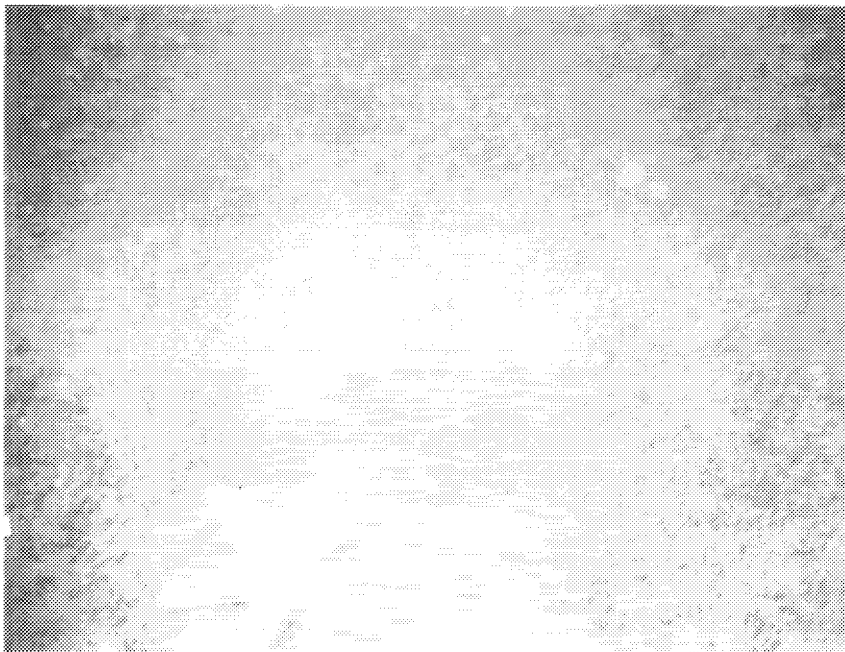

Figure 3-61. Starfish preying on infauna.



Figure 3-62. Spider crab foraging by winnowing amphipod tubes and sediment material through mandibles.

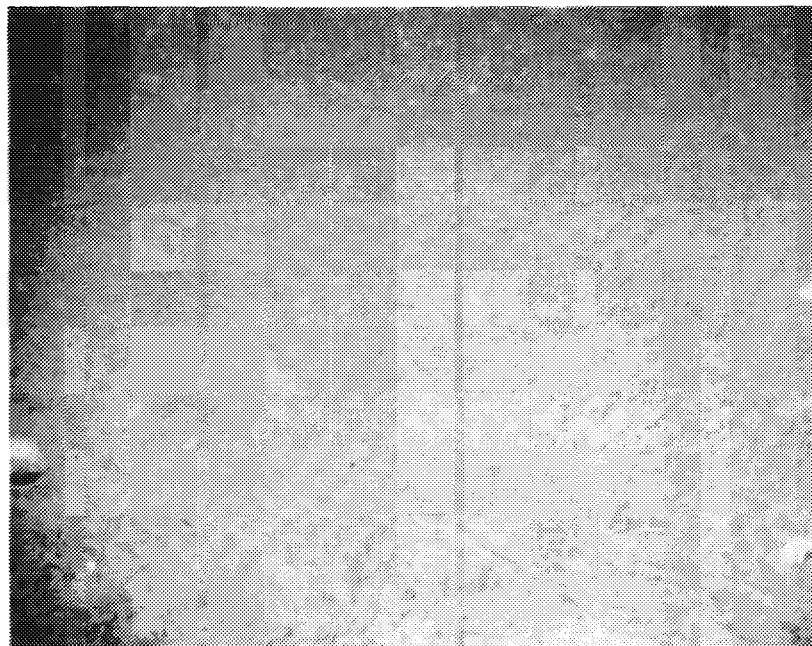

Figure 3-63. Mucous trail left by channeled whelk moving over sediment surface.