



**US Army Corps
of Engineers**®
New England District
696 Virginia Road
Concord, MA 01742-2751

PUBLIC NOTICE

Comment Period Begins: September 9, 2014
Comment Period Ends: October 8, 2014
File Number: NAE-2014-114
In Reply Refer To: Kevin Kotelly, P.E.
Phone: (978) 318-8703
E-mail: kevin.r.kotelly@usace.army.mil

The District Engineer has received a permit application to conduct work in waters of the United States from Algonquin Gas Transmission, LLC. This work is proposed in Beverly Harbor and Collins Cove in Salem, Massachusetts. The site coordinates are: Latitude 42.537160°, Longitude -70.882474°.

The work involves work, structures, and the discharge of fill material below the high tide line of waters of the United States in order to construct the Algonquin Gas Salem Lateral Project. The Salem Lateral Project includes the installation of 1.2 miles of new 16-inch diameter pipeline from the existing Hubline pipeline in Beverly Harbor to the Salem Harbor Electric Station to supply natural gas for electricity generation. The Salem Harbor Electric Station is converting from coal-fired electricity generation to natural gas-fired generation. The Salem Lateral Project begins at a new subsea tap connection with the Hubline pipeline and will run south to the Salem Harbor Electric Station.

The Salem Lateral will cross the marine areas of Beverly Harbor and Collins Cove using horizontal directional drilling (HDD) to minimize impacts to the marine environment. The Collins Cove HDD will be a land-to-land operation with no in-water work in Collins Cove. However, the Beverly Harbor HDD will involve a land-to-water operation, given that the tie-in location to the existing HubLine for the Salem Lateral is in-water. The Applicant will also need to conduct in-water construction work at the tie-in location to connect the Salem Lateral with the HubLine pipeline. In an effort to isolate in-water activities, the Applicant will install a temporary wet cofferdam in the area surrounding the subsea tie-in. Use of a cofferdam offers the opportunity to limit the amount of suspended sediments leaving the work area, thereby reducing potential impacts on marine resources. Based on design requirements and geotechnical soil analysis performed at the subsea tie-in location, the Applicant determined that the use of a “wet cofferdam” will provide the most efficient approach to perform the in-water work at the HDD exit hole and the Hubline connection point. The connection will be performed via a hot-tap onto the active Hubline.

The project will require the hydraulic dredging of an 85 foot by 55 foot area of the seafloor to a depth of 8.5 feet in Beverly Harbor. Approximately 1500 cubic yards of sediment will be excavated and placed in hopper barges for temporary storage and decanting. The decanted material will then be placed back into the cofferdam.

A permanent, concrete vault will be installed below the seafloor in order to conduct future internal inspections of the Salem Lateral line. The proposed vault will be about 8 feet by 10 feet. The upper elevation of this vault will lie approximately 1 foot below the existing seafloor elevation. Removing the vault cover will facilitate access to the Salem Lateral connection area and would only disturb about 80 square feet during maintenance. Removal of the estimated 1 foot of sediment located on the top of the vault cover would be done by diver hand jetting and would result in the suspension of about 4 cubic yards of bottom sediment into the water column.

CENAE-R
FILE NO. NAE-2014-114

Performing maintenance operations with the vault would require the mobilization of a support vessel. No temporary moorings or decanting barges would be needed. Once the maintenance activity is complete, the vault cover will be replaced and restoration will occur naturally through sediment deposition or the area will be backfilled with sandbags or some other suitable fill. Future maintenance activities will take approximately 12 days to complete.

The project will also include 0.67 acres of fill below the ordinary high water line of waters of the United States for the temporary fill of freshwater wetlands via swamp mats during the construction phase of the project where the pipeline will cross an overland section of Salem. Due to the use of HDD along the Salem Lateral alignment, the pipeline will not be constructed across any freshwater wetlands via open trenching. However, the workspace associated with the construction of the Salem Lateral will temporarily disturb a freshwater wetland in Salem. This workspace is necessary for the pullback of the Beverly Harbor HDD pipe sections and other support activities. Wooden mats will be placed to support construction equipment within the wetland. After construction, the mats will be removed and the wetlands will be restored in place.

The work is shown on the attached plans entitled, "I-System, Salem Lateral Project, Proposed 16" Line No. I-18, USACE Permit Drawing," on 23 sheets, and dated July 25, 2014.

In designing the Salem Lateral Project, the Applicant evaluated a number of routing and construction alternatives to address environmental impacts, as well as other concerns. The route selected and the HDD construction method will avoid and minimize impacts to aquatic resources, including intertidal area, saltmarsh, and freshwater wetlands. Temporary wetland impacts will be restored in place. Options for compensatory mitigation for unavoidable impacts are being considered by the Corps of Engineers.

AUTHORITY

Permits are required pursuant to:

- Section 10 of the Rivers and Harbors Act of 1899
- Section 404 of the Clean Water Act
- Section 103 of the Marine Protection, Research and Sanctuaries Act.

The decision whether to issue a permit will be based on an evaluation of the probable impact of the proposed activity on the public interest. That decision will reflect the national concern for both protection and utilization of important resources. The benefit which may reasonably accrue from the proposal must be balanced against its reasonably foreseeable detriments. All factors which may be relevant to the proposal will be considered, including the cumulative effects thereof; among those are: conservation, economics, aesthetics, general environmental concerns, wetlands, cultural value, fish and wildlife values, flood hazards, flood plain value, land use, navigation, shoreline erosion and accretion, recreation, water supply and conservation, water quality, energy needs, safety, food production and, in general, the needs and welfare of the people.

The Corps of Engineers is soliciting comments from the public; Federal, state, and local agencies and officials; Indian Tribes; and other interested parties in order to consider and evaluate the impacts of this proposed activity. Any comments received will be considered by the Corps of Engineers to determine whether to issue, modify, condition or deny a permit for this proposal. To make this decision, comments are used to assess impacts on endangered species, historic properties, water quality, general environmental effects, and the other public interest factors listed above. Comments are used in the preparation of an Environmental Assessment and/or an Environmental Impact Statement pursuant to the National Environmental Policy Act. Comments are

CENAE-R
FILE NO. NAE-2014-114

also used to determine the need for a public hearing and to determine the overall public interest of the proposed activity.

Where the activity involves the discharge of dredged or fill material into waters of the United States or the transportation of dredged material for the purpose of disposing it in ocean waters, the evaluation of the impact of the activity in the public interest will also include application of the guidelines promulgated by the Administrator, U.S Environmental Protection Agency, under authority of Section 404(b) of the Clean Water Act, and/or Section 103 of the Marine Protection Research and Sanctuaries Act of 1972, as amended.

ESSENTIAL FISH HABITAT

The Magnuson-Stevens Fishery Conservation and Management Act, as amended by the Sustainable Fisheries Act of 1996 (Public Law 104-267), requires all federal agencies to consult with the National Marine Fisheries Service on all actions, or proposed actions, permitted, funded, or undertaken by the agency, that may adversely affect Essential Fish Habitat (EFH).

This project will impact 4675 SF of Essential Fish Habitat (EFH) for Atlantic cod (*Gadus morhua*), haddock (*Melanogrammus aeglefinus*), pollock (*Pollachius virens*), whiting (*Merluccius bilinearis*), red hake (*Urophycis chuss*), white hake (*Urophycis tenuis*), redfish (*Sebastes fasciatus*), winter flounder (*Pseudopleuronectes americanus*), yellowtail flounder (*Limanda ferruginea*), windowpane flounder (*Scophthalmus aquosus*), American plaice (*Hippoglossoides platessoides*), ocean pout (*Macrozoarces americanus*), Atlantic halibut (*Hippoglossus hippoglossus*), Atlantic sea scallop (*Placopecten magellanicus*), Atlantic sea herring (*Clupea harengus*), bluefish (*Pomatomus saltatrix*), long finned squid (*Loligo pealeii*), short finned squid (*Illex illecebrosus*), Atlantic butterflyfish (*Peprilus triacanthus*), Atlantic mackerel (*Scomber scombrus*), summer flounder (*Paralichthys dentatus*), scup (*Stenotomus chrysops*), black sea bass (*Centropristis striata*), surf clam (*Spisula solidissima*), and bluefin tuna (*Thunnus thynnus*). This habitat consists of unvegetated, sandy bottom. Loss of this habitat may adversely affect the species listed above. However, the District Engineer has made a preliminary determination that the site-specific adverse effect will not be substantial. Further consultation with the National Marine Fisheries Service regarding EFH conservation recommendations is being conducted and will be concluded prior to the final decision.

NATIONAL HISTORIC PRESERVATION ACT

Based on his initial review, the District Engineer has determined that little likelihood exists for the proposed work to impinge upon properties with cultural or Native American significance, or listed in, or eligible for listing in, the National Register of Historic Places. Therefore, no further consideration of the requirements of Section 106 of the National Historic Preservation Act of 1966, as amended, is necessary. This determination is based upon one or more of the following:

- a. The permit area has been extensively modified by previous work.
- b. The permit area has been recently created.
- c. The proposed activity is of limited nature and scope.
- d. Review of the latest published version of the National Register shows that no presence of registered properties listed as being eligible for inclusion therein are in the permit area or general vicinity.
- e. Coordination with the State Historic Preservation Officer and/or Tribal Historic Preservation Officer(s)

ENDANGERED SPECIES CONSULTATION

The New England District, Army Corps of Engineers has reviewed the list of species protected under the Endangered Species Act of 1973, as amended, which might occur at the project site. It is our preliminary determination that the proposed activity for which authorization is being sought is designed, situated or will be operated/used in such a manner that it is not likely to adversely affect any Federally listed endangered or threatened species or their designated critical habitat. By this Public Notice, we are requesting that the appropriate Federal Agency concur with our determination.

COASTAL ZONE MANAGEMENT

The States of Connecticut, Maine, Massachusetts, New Hampshire and Rhode Island have approved **Coastal Zone Management Programs**. Where applicable, the applicant states that any proposed activity will comply with and will be conducted in a manner that is consistent with the approved Coastal Zone Management Program. By this Public Notice, we are requesting the State concurrence or objection to the applicant's consistency statement.

The following authorizations have been applied for, or have been, or will be obtained:

- (X) Permit, License or Assent from State.
- (X) Permit from Local Wetland Agency or Conservation Commission.
- (X) Water Quality Certification in accordance with Section 401 of the Clean Water Act.

In order to properly evaluate the proposal, we are seeking public comment. Anyone wishing to comment is encouraged to do so. Comments should be submitted in writing by the above date. If you have any questions, please contact Kevin Kotelly at (978) 318-8703, (800) 343-4789 or (800) 362-4367, if calling from within Massachusetts.

Any person may request, in writing, within the comment period specified in this notice, that a public hearing be held to consider the application. Requests for a public hearing shall specifically state the reasons for holding a public hearing. The Corps holds public hearings for the purpose of obtaining public comments when that is the best means for understanding a wide variety of concerns from a diverse segment of the public.

The initial determinations made herein will be reviewed in light of facts submitted in response to this notice. All comments will be considered a matter of public record. Copies of letters of objection will be forwarded to the applicant who will normally be requested to contact objectors directly in an effort to reach an understanding.

THIS NOTICE IS NOT AN AUTHORIZATION TO DO ANY WORK.



Karen K. Adams
Chief, Permits and Enforcement Branch
Regulatory Division

CENAE-R
FILE NO. NAE-2014-114

If you would prefer not to continue receiving Public Notices by email, please contact Ms. Tina Chaisson at (978) 318-8058 or e-mail her at bettina.m.chaisson@usace.army.mil. You may also check here () and return this portion of the Public Notice to: Bettina Chaisson, Regulatory Division, U.S. Army Corps of Engineers, 696 Virginia Road, Concord, MA 01742-2751.

NAME: _____
ADDRESS: _____
PHONE: _____

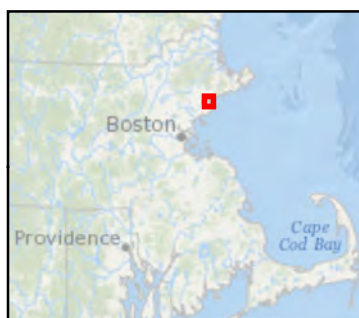
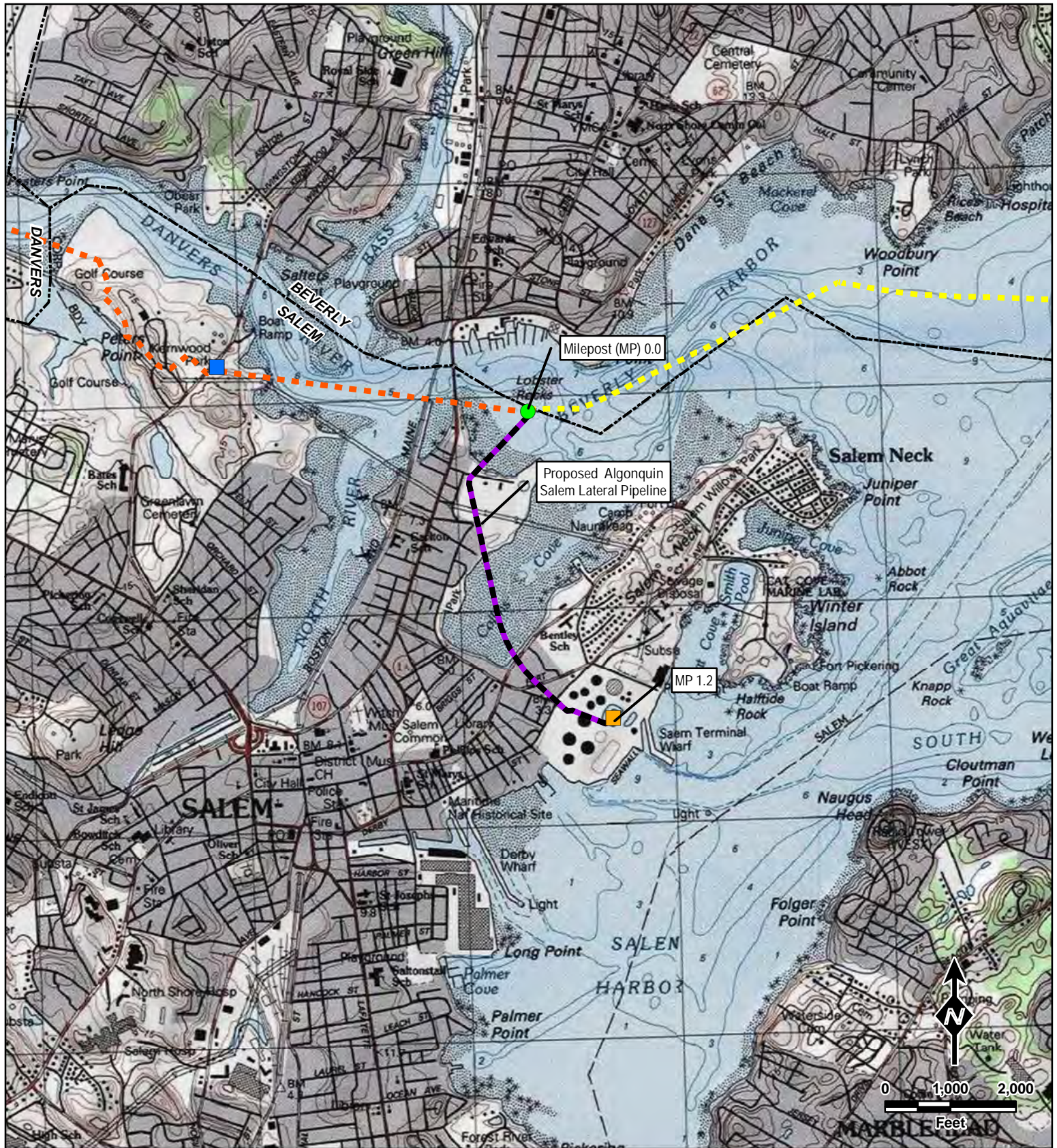

Data Sources: ESRI, SPECTRA, USGS, TRC

Legend

- Proposed Algonquin Salem Lateral Pipeline
- - - Existing Algonquin HubLine Pipeline
- - - Existing Maritimes & Northeast Phase III Pipeline
- Town Boundary
- Tie-in with Existing Algonquin HubLine Pipeline
- Existing Maritimes & Northeast Salem M&R Station
- Proposed Algonquin Salem Lateral M&R Station



Algonquin Gas Transmission, LLC
Salem Lateral Project
 Salem/Beverly, MA

Figure 2.1-1

Created: 7/28/2014

\\PROJECT\SIG\GUSTAS\SPECTRA\Salem\WOC_Eigure2_1_1_USGS.mxd

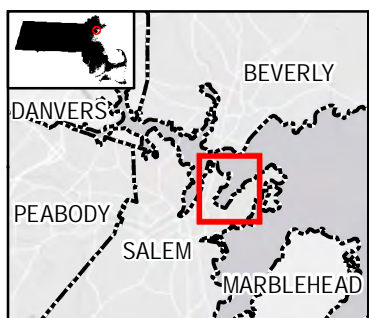
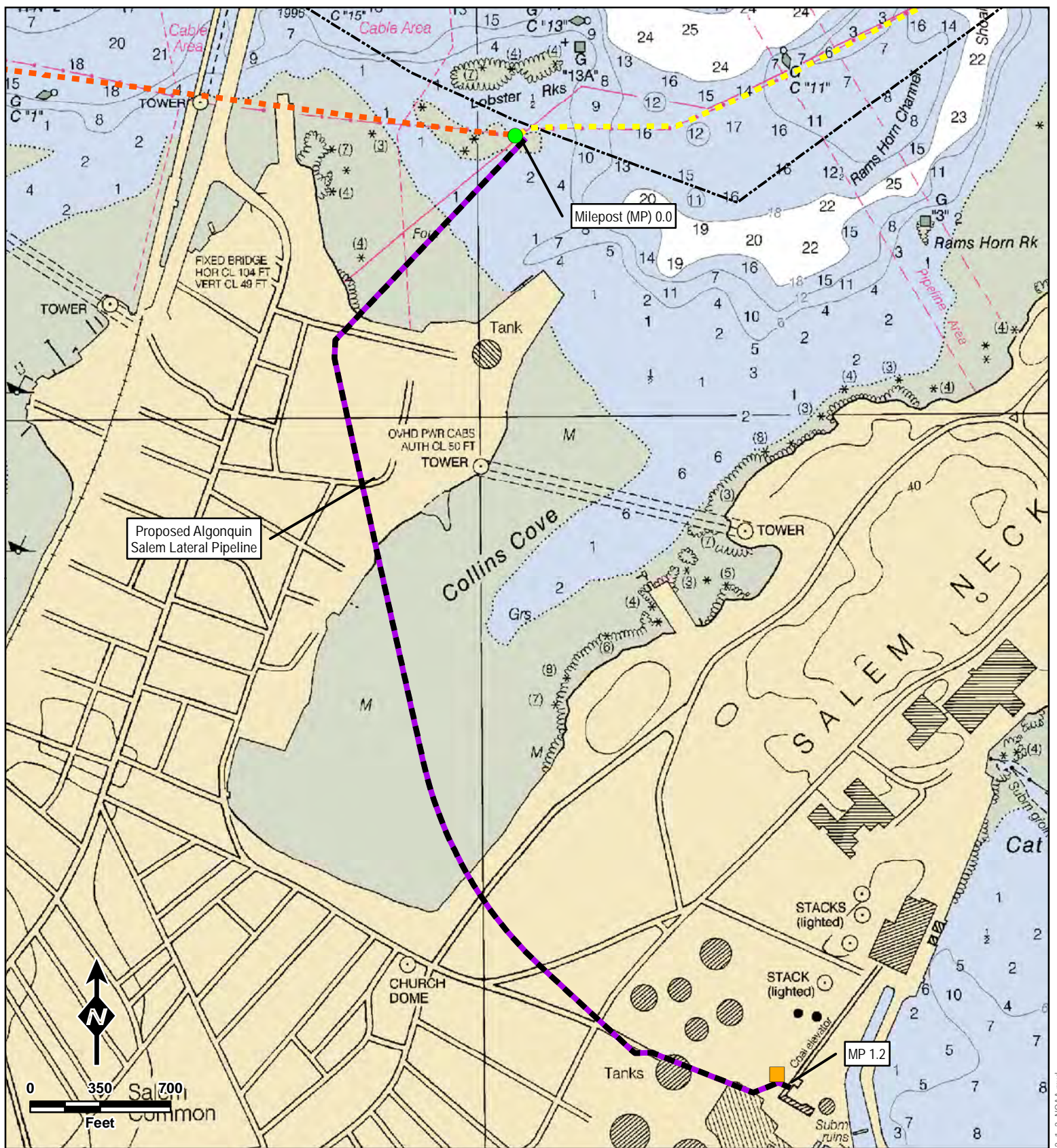

- Legend**
- Proposed Salem Lateral Pipeline
 - - - Existing Algonquin HubLine Pipeline
 - - - Existing Maritimes & Northeast Phase III Pipeline
 - Town Boundary
 - Tie-in with Existing Algonquin HubLine Pipeline
 - Existing Maritimes & Northeast Salem M&R Station
 - Proposed Algonquin Salem Lateral M&R Station

Spectra Energy Partners
 Algonquin Gas Transmission, LLC
Salem Lateral Project
 Salem/Beverly, MA
 Figure 2.1-2
 Created: 7/25/2014

LEGEND	
PROPOSED PIPELINE	
HDD ENTRY/EXIT POINT	
LIMITS OF DISTURBANCE	
PERMANENT EASEMENT	
CONTOURS	
PROPERTY LINE	
SALT MARSH	
DELINEATED FRESHWATER WETLAND BOUNDARY	
WETLAND BOUNDARY WITHIN TEMPORARY WORKSPACE	
TOP OF COASTAL BANK	
SILT FENCE	
MEAN LOW WATER (EL: -4.679')	
MEAN HIGH WATER (EL: 4.328')	
HIGH TIDE LINE	
FLOOD PLAIN LIMITS	

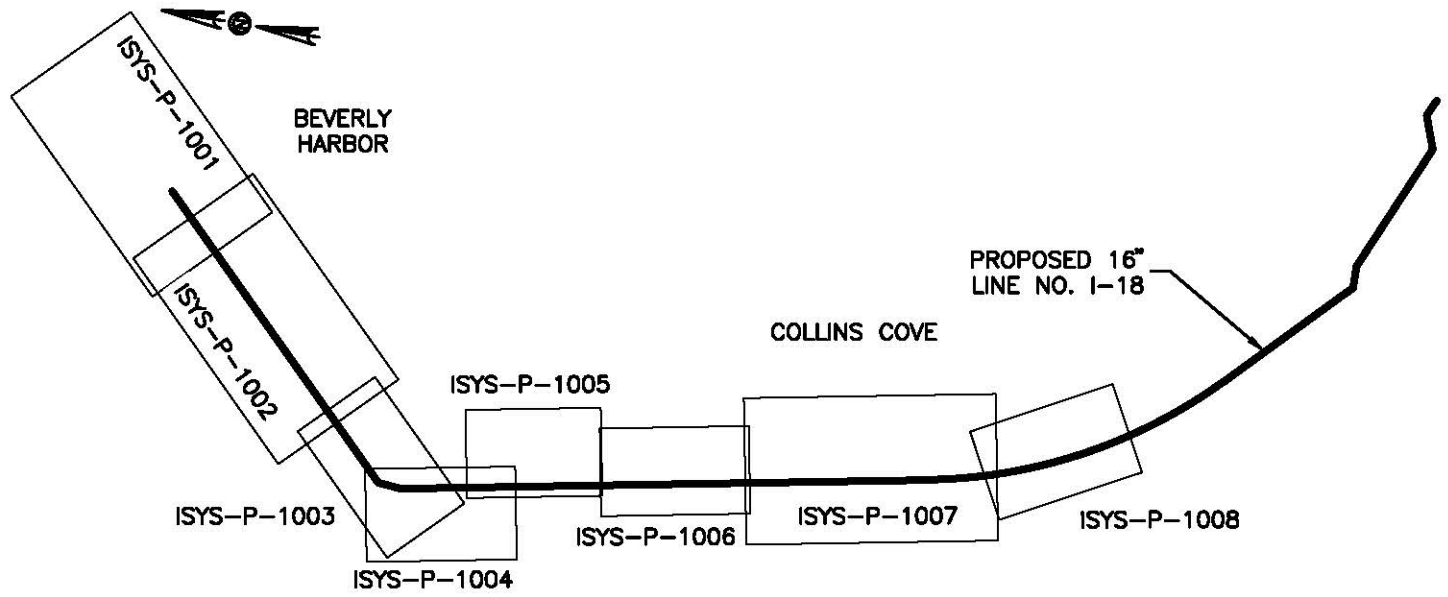

KEY SHEET
SCALE: N.T.S.

NOTES:

1. NO PERMANENT WETLAND IMPACTS ASSOCIATED WITH PROJECT
2. WETLAND RESOURCES WERE FIELD DELINEATED AND SURVEYED BY TRC ON 1/14/14.
3. 100-YEAR FLOOD ZONE (ZONE AE) LIMITS SHOWN BASED ON FEMA FLOOD INSURANCE RATE MAP NOS. 25009C0417G AND 25009C0419G, EFFECTIVE JULY 16, 2014.
4. CONTRACTOR TO COMPLY WITH ALL APPLICABLE PROVISIONS OF SPECTRA ENERGY EROSION & SEDIMENTATION CONTROL PLAN.
5. THE FINAL IMPLEMENTATION AND LOCATION OF EROSION AND SEDIMENT CONTROLS WILL BE DETERMINED BY A SPECTRA ENERGY ENVIRONMENTAL INSPECTOR.
6. EXISTING CONDITIONS AND PROPERTY INFORMATION COMPILED FROM INFORMATION PROVIDED BY VHB (COORDINATE SYSTEM: UTM ZONE 18 / NAD 83, ELEVATION DATUM: NAVD 88)
7. BATHYMETRY SHOWN BASED ON SURVEYS PERFORMED BY OSI ON 11/6/2013 TO 11/9/2013.
8. MLW AND MHW ELEVATIONS SHOWN ARE REFERENCED TO THE SALEM HARBOR TIDE STATION #8442645 WHICH PLACES MLLW AT EL. -5.0593'.
9. PROPERTY LINES ARE BASED ON TAX MAPS, PLANS/DEEDS OF RECORD AND ARE NOT THE RESULT OF A FULL BOUNDARY SURVEY.



**Hatch Mott
MacDonald**

150 LOWER WESTFIELD ROAD
HOLYOKE, MASSACHUSETTS 01040
PHONE (413) 535-0135
FAX (413) 535-0136

I-SYSTEM
SALEM LATERAL PROJECT
PROPOSED 16" LINE NO. I-18
USACE PERMIT DRAWING



Algonquin Gas Transmission, LLC
5400 Westheimer Ct. Houston, TX 77056-5310 713/627-5400

LOC.: ESSEX COUNTY, MASSACHUSETTS		DATE: 07/25/2014		W.B.S.:	
DRN. BY: HMM		SCALE: NOT TO SCALE		SHT.: 01 OF 19	
CKD. BY: HMM		DWG NO.: ISYS-P-1001		REV.:	
ENG.:					

P:\Spectra\Salem\lateral\DataProd\Work\Drafting\USACE_Details\USACE_Detail_2 -Plan

I.G.

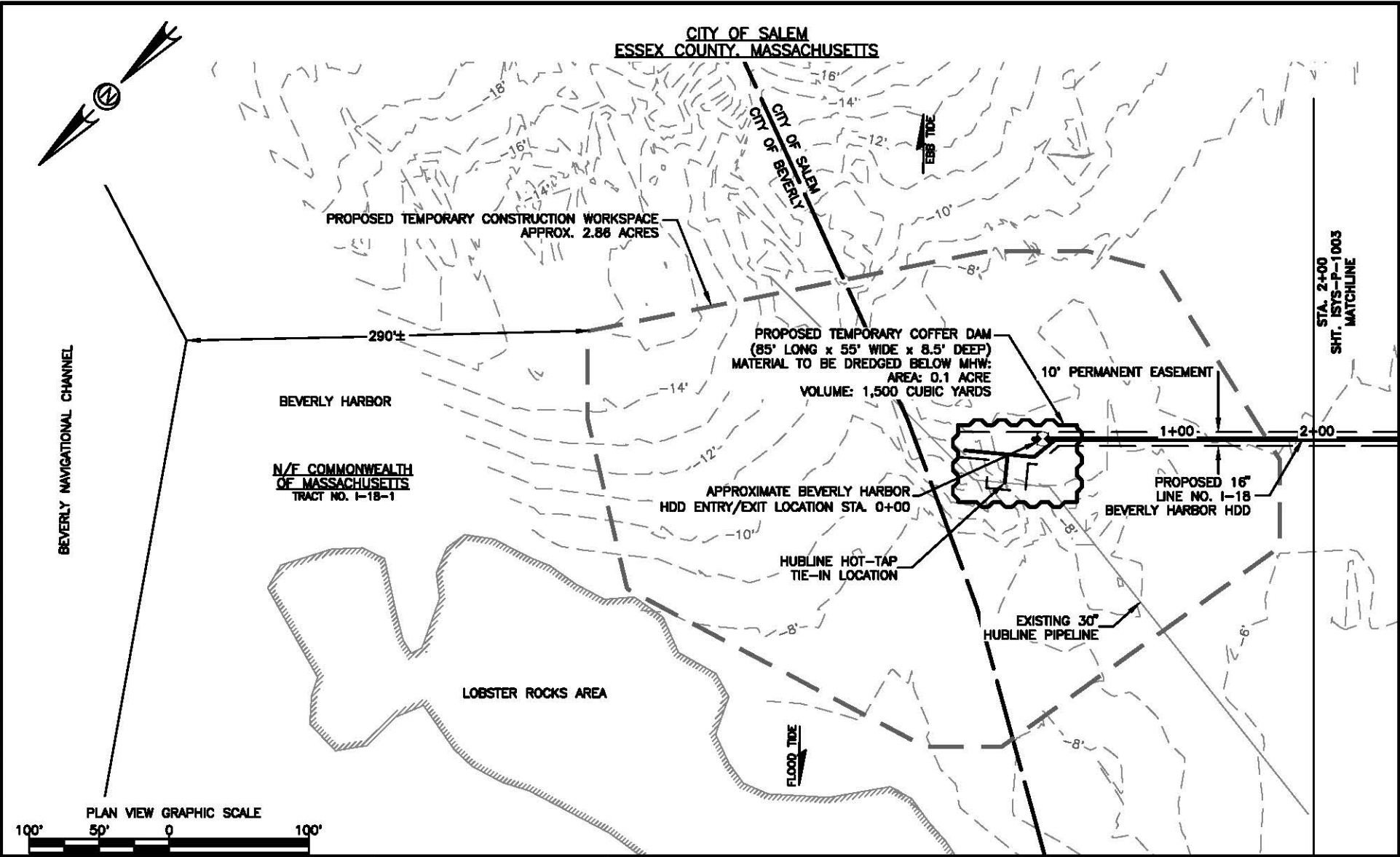

**Hatch Mott
MacDonald**

150 LOWER WESTFIELD ROAD
HOLYOKE, MASSACHUSETTS 01040
PHONE (413) 535-0135
FAX (413) 535-0136

I-SYSTEM
SALEM LATERAL PROJECT
PROPOSED 16" LINE NO. I-18
USACE PERMIT DRAWING



Algonquin Gas Transmission, LLC
5400 Westheimer Ct. Houston, TX 77056-5310 713/627-5400

LOC.: ESSEX COUNTY, MASSACHUSETTS		DATE: 07/25/2014		W.B.S.:	
DRN. BY: HMM		SCALE: 1" = 100'		SHT.: 02 OF 19	
CKD. BY: HMM		DWG NO.: ISYS-P-1002		REV.:	
ENG.:					

P:\Spectra\Salem\lateral\DataProd\Work\Drafting\USACE_Details\USACE_Detail_2 -Plan.dwg

CITY OF SALEM
ESSEX COUNTY, MASSACHUSETTS

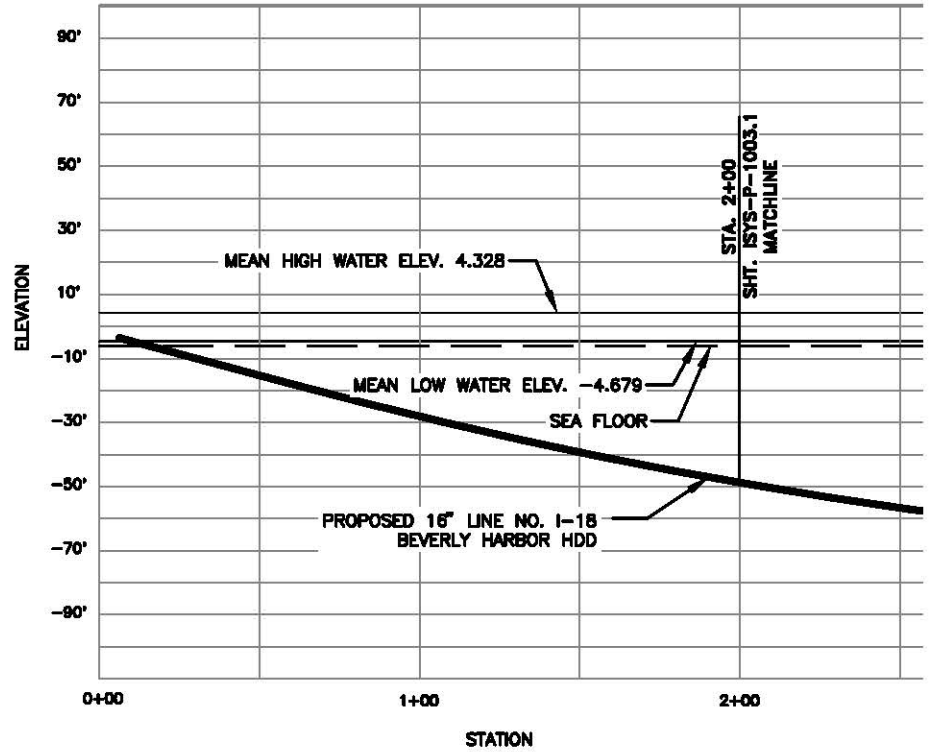

PROFILE SCALE:
1"=60' HORIZ.
1"=60' VERT.



**Hatch Mott
MacDonald**

150 LOWER WESTFIELD ROAD
HOLYOKE, MASSACHUSETTS 01040
PHONE (413) 535-0135
FAX (413) 535-0136

I-SYSTEM
SALEM LATERAL PROJECT
PROPOSED 16" LINE NO. I-18
USACE PERMIT DRAWING



Algonquin Gas Transmission, LLC
5400 Westheimer Ct. Houston, TX 77056-5310 713/627-5400

LOC.: ESSEX COUNTY, MASSACHUSETTS		DATE: 07/25/2014	W.B.S.: CE.000064.001
DRN. BY: HMM		SCALE: 1"=60'	SHT.: 03 OF 19
CKD. BY: HMM		DWG NO.: ISYS-P-1002.1	REV.:
ENG.:			

I.G.

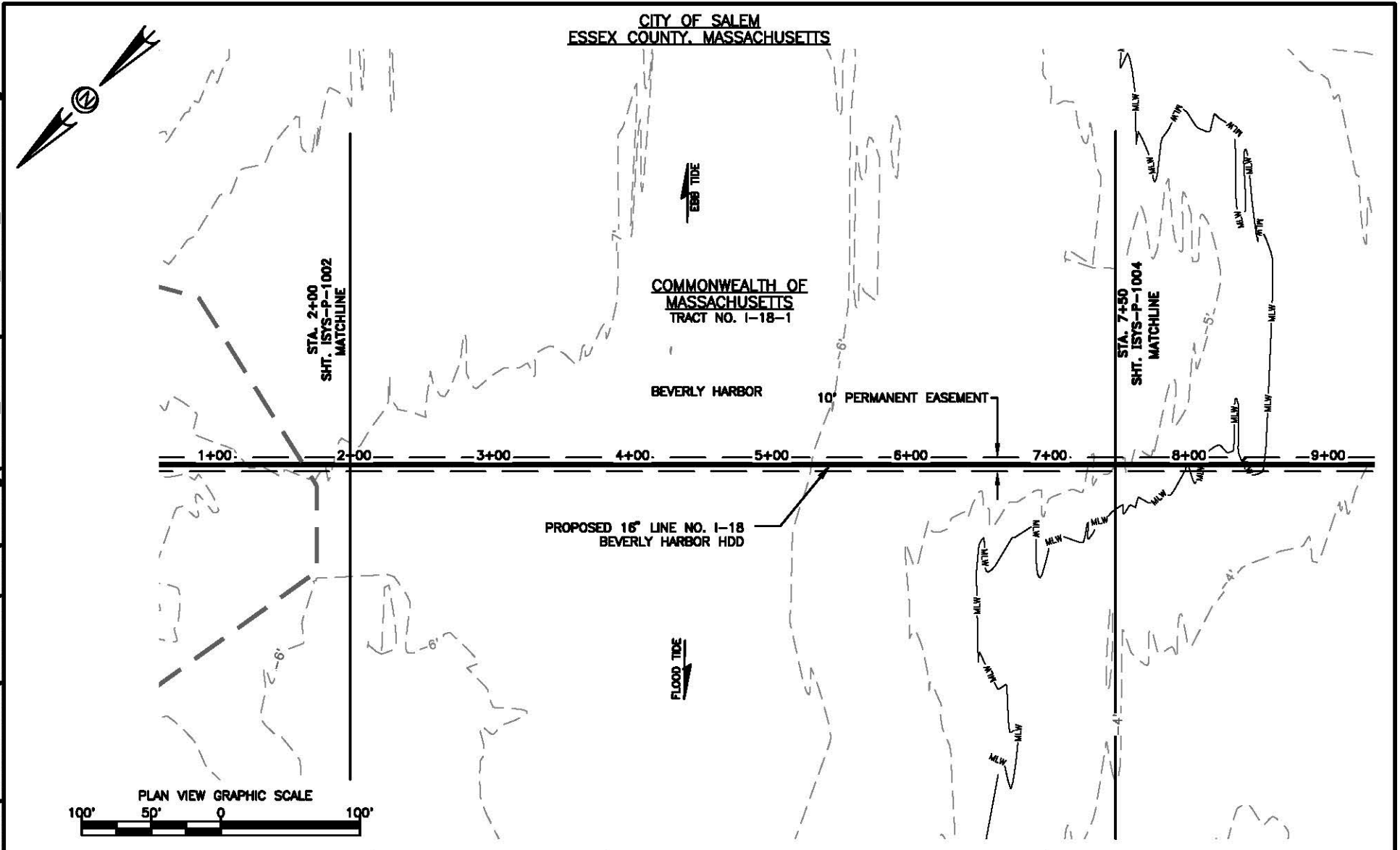

**Hatch Mott
MacDonald**

150 LOWER WESTFIELD ROAD
HOLYOKE, MASSACHUSETTS 01040
PHONE (413) 535-0135
FAX (413) 535-0136

I-SYSTEM
SALEM LATERAL PROJECT
PROPOSED 16" LINE NO. I-18
USACE PERMIT DRAWING



Algonquin Gas Transmission, LLC
5400 Westheimer Ct. Houston, TX 77056-5310 713/627-5400

LOC.: ESSEX COUNTY, MASSACHUSETTS

DRN. BY: HMM

CKD. BY: HMM

ENG.:

DATE: 07/25/2014

SCALE: 1"=100'

DWG NO.: ISYS-P-1003

W.B.S.: CE.000064.001

SHT.: 04 OF 19

REV.:

CITY OF SALEM
ESSEX COUNTY, MASSACHUSETTS

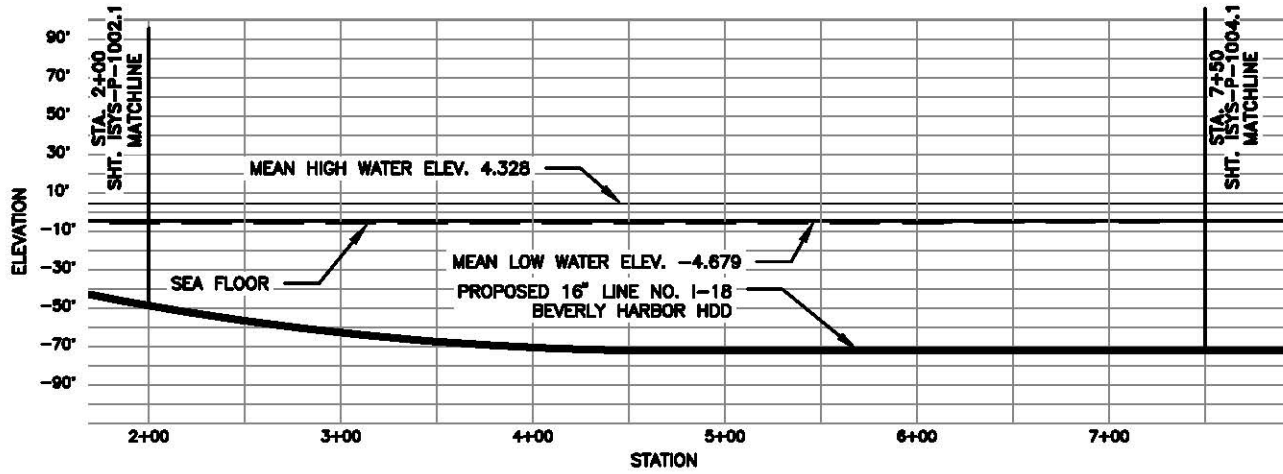

PROFILE SCALE:
1"=100' HORIZ.
1"=100' VERT.



**Hatch Mott
MacDonald**

150 LOWER WESTFIELD ROAD
HOLYOKE, MASSACHUSETTS 01040
PHONE (413) 535-0135
FAX (413) 535-0136

I-SYSTEM
SALEM LATERAL PROJECT
PROPOSED 16" LINE NO. I-18
USACE PERMIT DRAWING



Algonquin Gas Transmission, LLC
5400 Westheimer Ct. Houston, TX 77056-5310 713/627-5400

LOC.: ESSEX COUNTY, MASSACHUSETTS

DRN. BY: HMM

CKD. BY: HMM

ENG.:

DATE: 07/25/2014

SCALE: 1"=100'

DWG NO.: ISYS-P-1003.I

W.B.S.: CE.000064.001

SHT.: 05 OF 19

REV.:

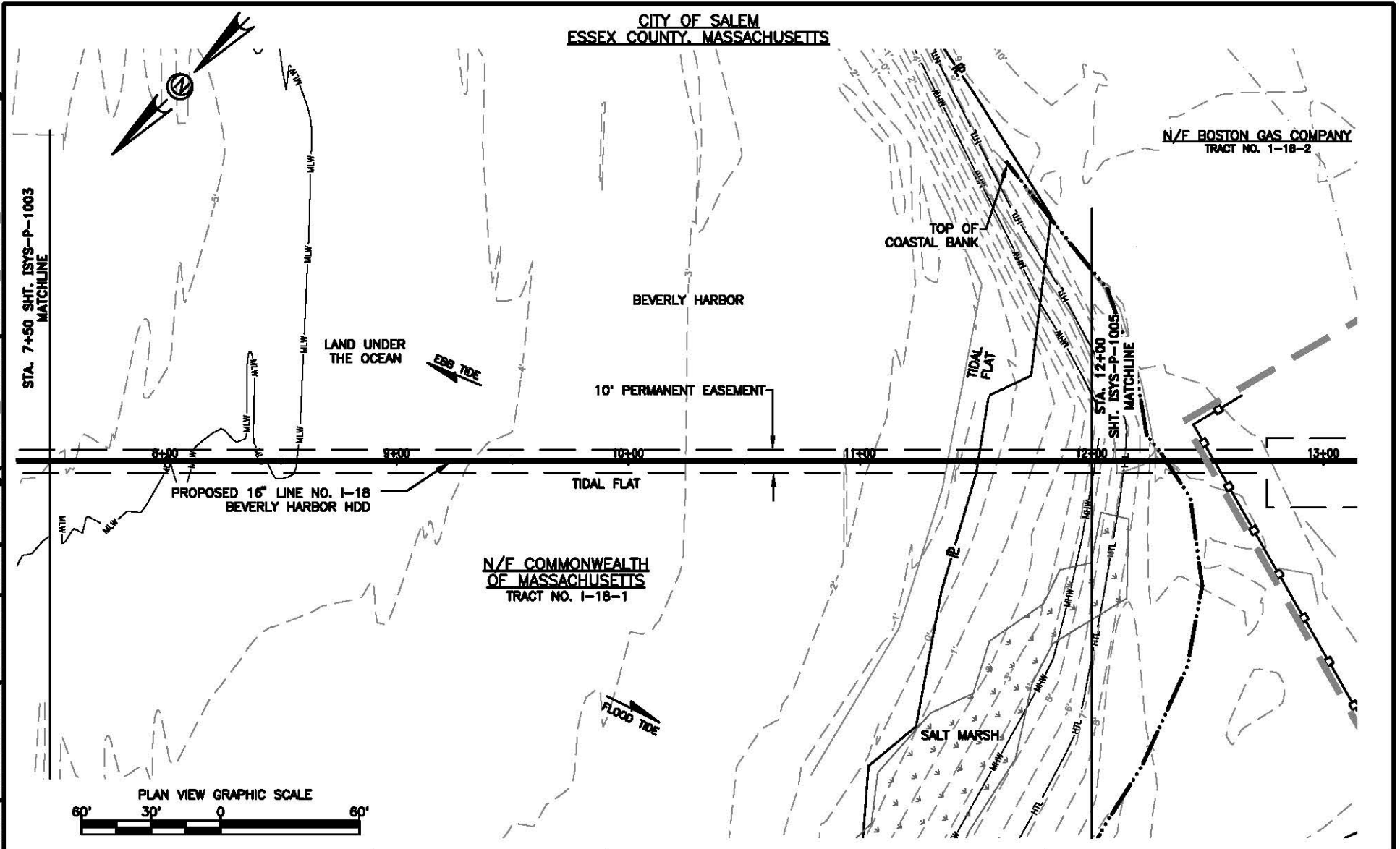

**Hatch Mott
MacDonald**

150 LOWER WESTFIELD ROAD
HOLYOKE, MASSACHUSETTS 01040
PHONE (413) 535-0135
FAX (413) 535-0136

I-SYSTEM
SALEM LATERAL PROJECT
PROPOSED 16" LINE NO. I-18
USACE PERMIT DRAWING

**Spectra Energy
Partners.**

Algonquin Gas Transmission, LLC
5400 Westheimer Ct. Houston, TX 77056-5310 713/627-5400

LOC.: ESSEX COUNTY, MASSACHUSETTS

DRN. BY: HMM

CKD. BY: HMM

ENG.:

DATE: 07/25/2014

SCALE: 1"=60'

DWG NO.: I-SYS-1004

W.B.S.: CE.000064.001

SHT.: 06 OF 19

REV.:

CITY OF SALEM
ESSEX COUNTY, MASSACHUSETTS

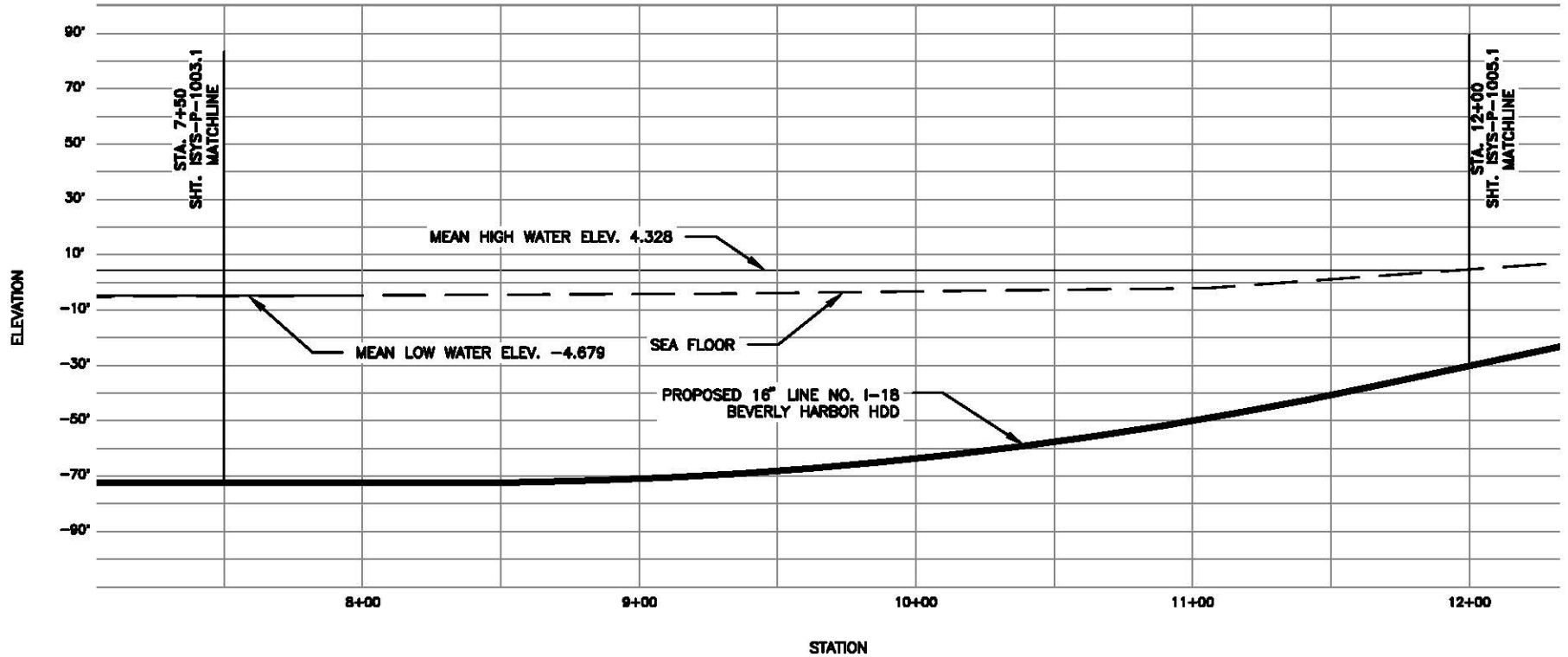

PROFILE SCALE:
1"=60' HORIZ.
1"=60' VERT.



**Hatch Mott
MacDonald**

150 LOWER WESTFIELD ROAD
HOLYOKE, MASSACHUSETTS 01040
PHONE (413) 535-0135
FAX (413) 535-0136

I-SYSTEM
SALEM LATERAL PROJECT
PROPOSED 16" LINE NO. I-18
USACE PERMIT DRAWING



Algonquin Gas Transmission, LLC
5400 Westheimer Ct. Houston, TX 77056-5310 713/627-5400

LOC.: ESSEX COUNTY, MASSACHUSETTS

DRN. BY: HMM

DATE: 07/25/2014

W.B.S.: CE.000064.001

CKD. BY: HMM

SCALE: 1"=60'

SHT.: 07 OF 19

ENG.:

DWG NO.: ISYS-P-1004.1

REV.:

P:\Spectra\SalemLateral\DataProd\Work\Drafting\USACE_Details\USACE_Detail_8-Plan.dwg

I.G.

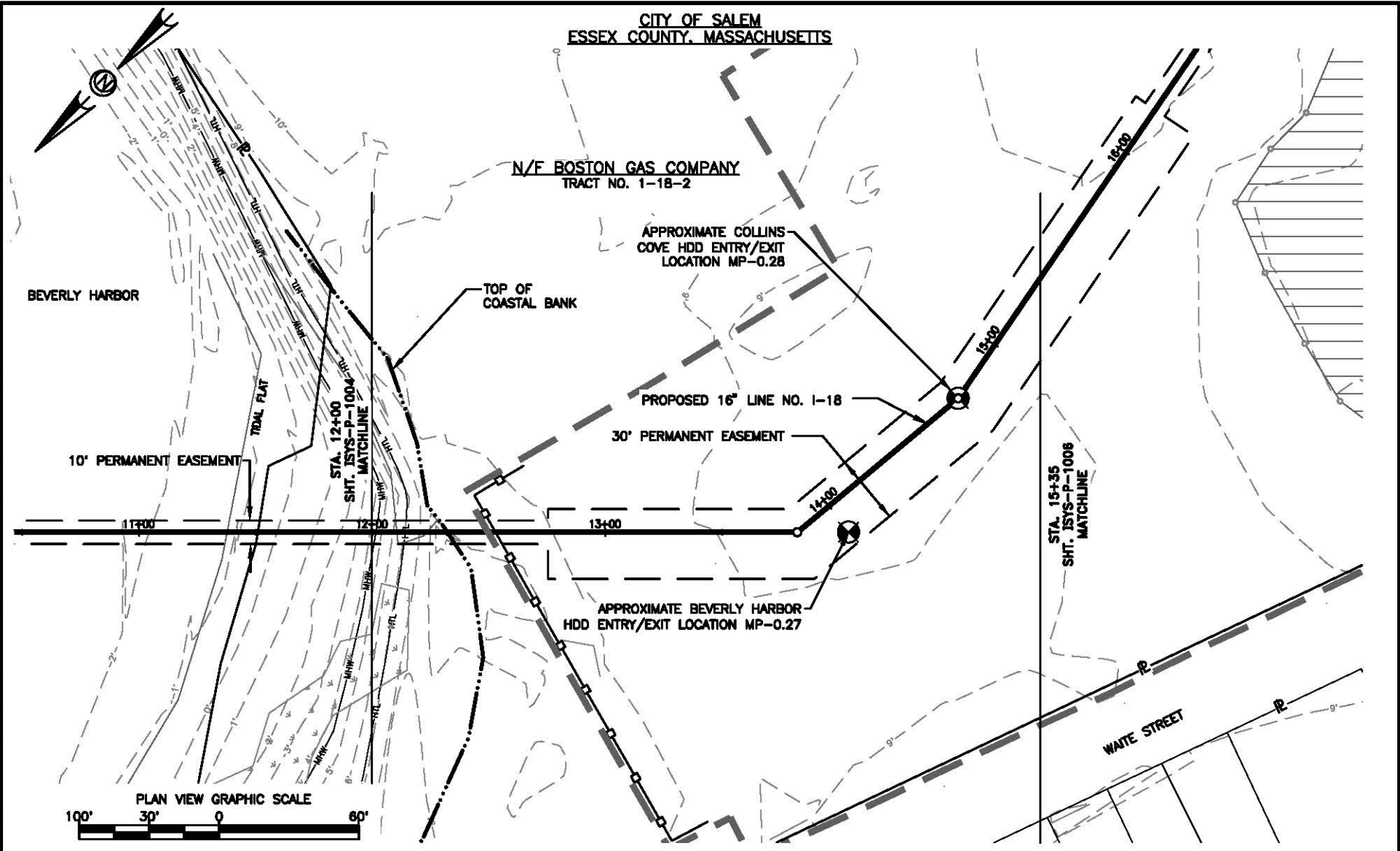

Hatch Mott MacDonald

150 LOWER WESTFIELD ROAD
HOLYOKE, MASSACHUSETTS 01040
PHONE (413) 535-0135
FAX (413) 535-0136

I-SYSTEM
SALEM LATERAL PROJECT
PROPOSED 16" LINE NO. 1-18
USACE PERMIT DRAWING



Algonquin Gas Transmission, LLC
5400 Westheimer Ct. Houston, TX 77056-5310 713/627-5400

LOC.: ESSEX COUNTY, MASSACHUSETTS		DATE: 07/25/2014	W.B.S.: CE.000064.001
DRN. BY: HMM		SCALE: 1"=60'	SHT.: 08 OF 19
CKD. BY: HMM		DWG NO.: ISYS-P-1005	REV.:
ENG.:			

P:\Spectra\Salem\Laterals\DataProd\Work\Drafting\USACE_Details\USACE_Detail_8-Plan.dwg

CITY OF SALEM
ESSEX COUNTY, MASSACHUSETTS

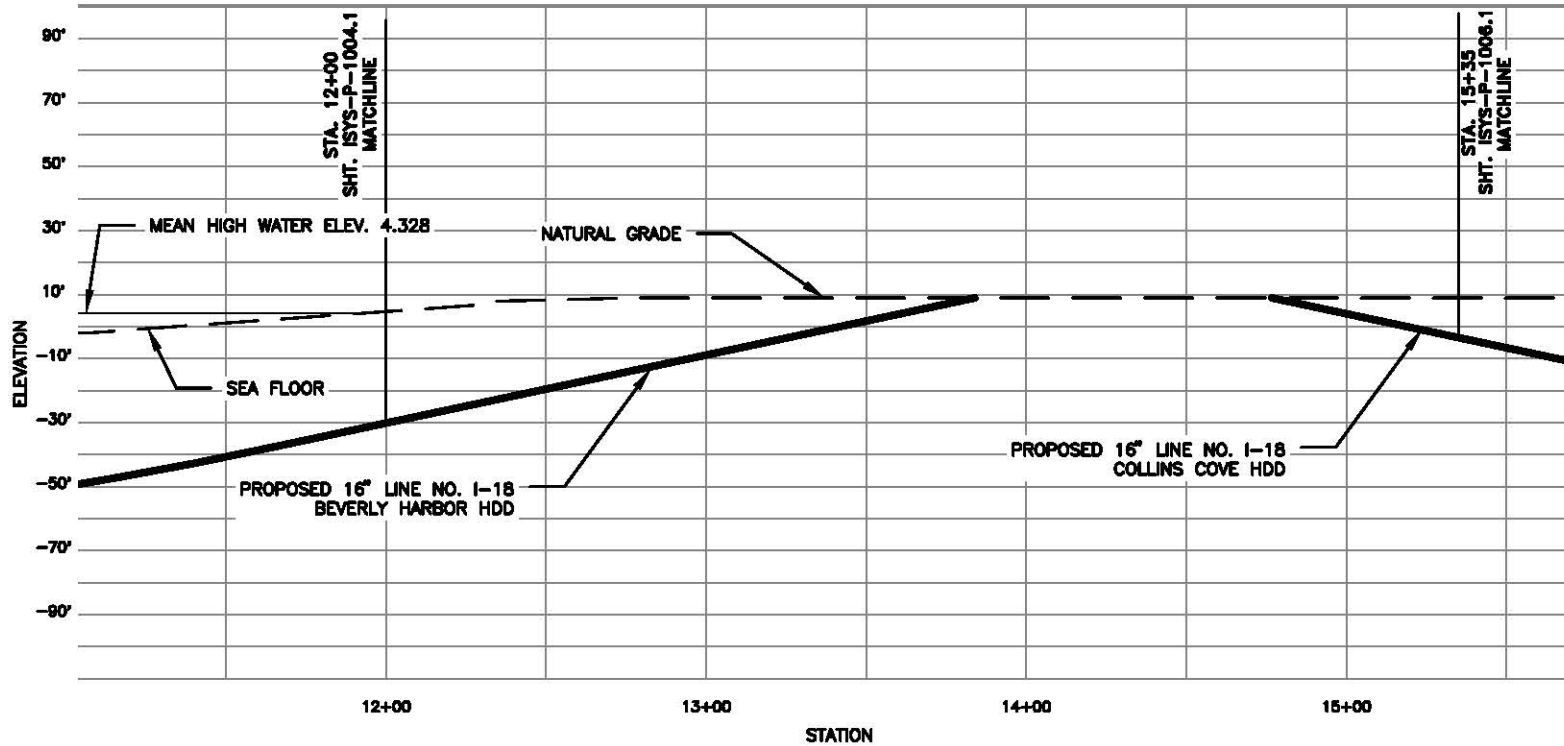

PROFILE SCALE:
1"=60' HORIZ.
1"=60' VERT.



**Hatch Mott
MacDonald**

150 LOWER WESTFIELD ROAD
HOLYOKE, MASSACHUSETTS 01040
PHONE (413) 535-0135
FAX (413) 535-0136

I-SYSTEM
SALEM LATERAL PROJECT
PROPOSED 16" LINE NO. 1-18
USACE PERMIT DRAWING



Algonquin Gas Transmission, LLC
5400 Westheimer Ct. Houston, TX 77056-5310 713/627-5400

LOC.: ESSEX COUNTY, MASSACHUSETTS

DRN. BY: HMM

DATE: 07/25/2014

W.B.S.: CE.000064.001

CKD. BY: HMM

SCALE: 1"=60'

SHT.: 09 OF 19

ENG.:

DWG NO.: ISYS-P-1005.1

REV.:

I.G.

P:\Spectra\Salem\ateral\DataProd\Work\Drafting\USACE_Details\USACE_Detail_6 -
Pch.dwg

I.G.

CITY OF SALEM
ESSEX COUNTY, MASSACHUSETTS

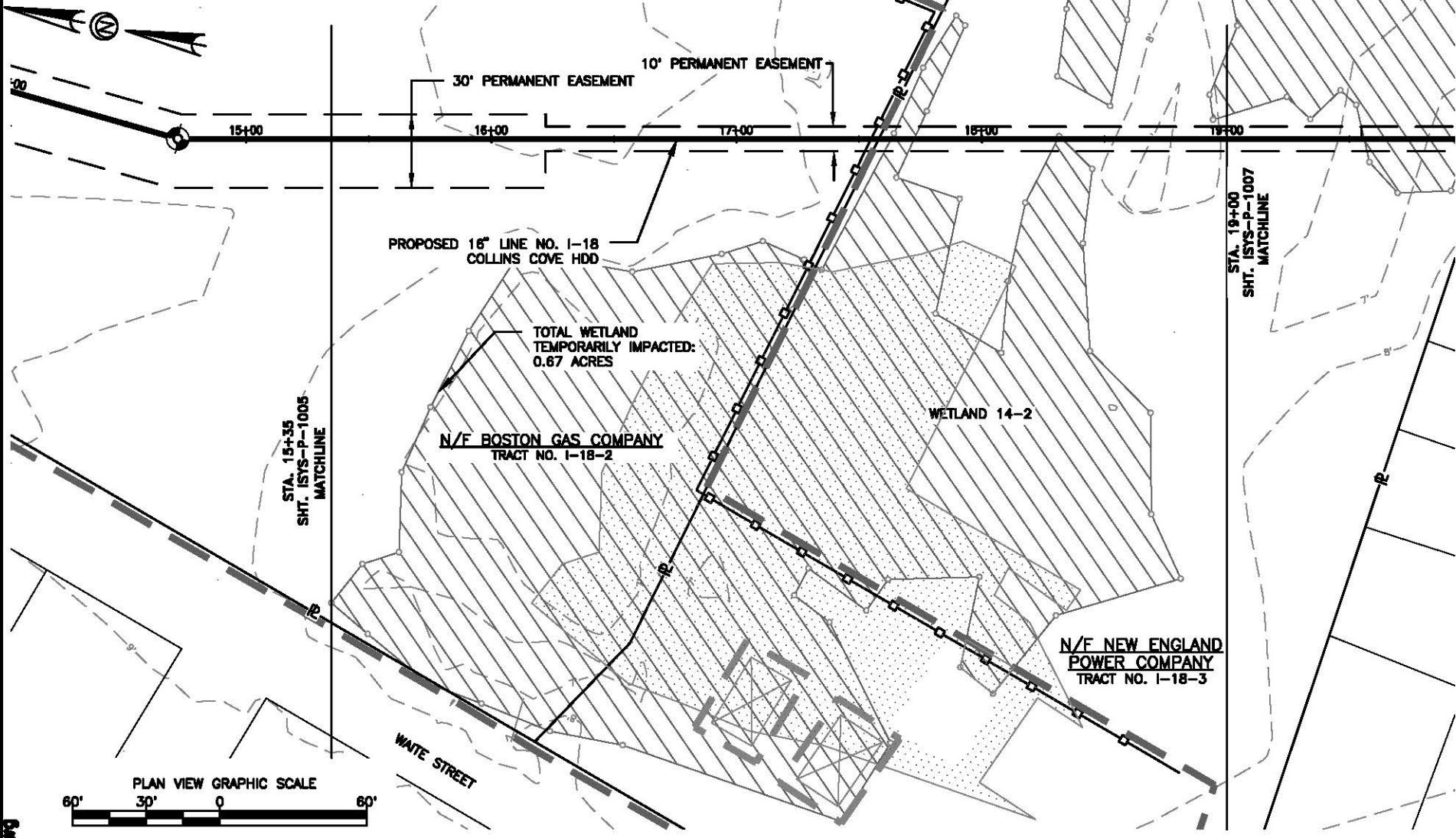

**Hatch Mott
MacDonald**

150 LOWER WESTFIELD ROAD
HOLYOKE, MASSACHUSETTS 01040
PHONE (413) 535-0135
FAX (413) 535-0136

I-SYSTEM
SALEM LATERAL PROJECT
PROPOSED 16" LINE NO. I-18
USACE PERMIT DRAWING



Algonquin Gas Transmission, LLC
5400 Westheimer Ct. Houston, TX 77056-5310 713/627-5400

LOC.: ESSEX COUNTY, MASSACHUSETTS		DATE: 07/25/2014	W.B.S.: CE.000064.001
DRN. BY: HMM		SCALE: 1"=60'	SHT.: 10 OF 19
CKD. BY: HMM		DWG NO.: ISYS-P-1006	REV.:
ENG.:			

CITY OF SALEM
ESSEX COUNTY, MASSACHUSETTS

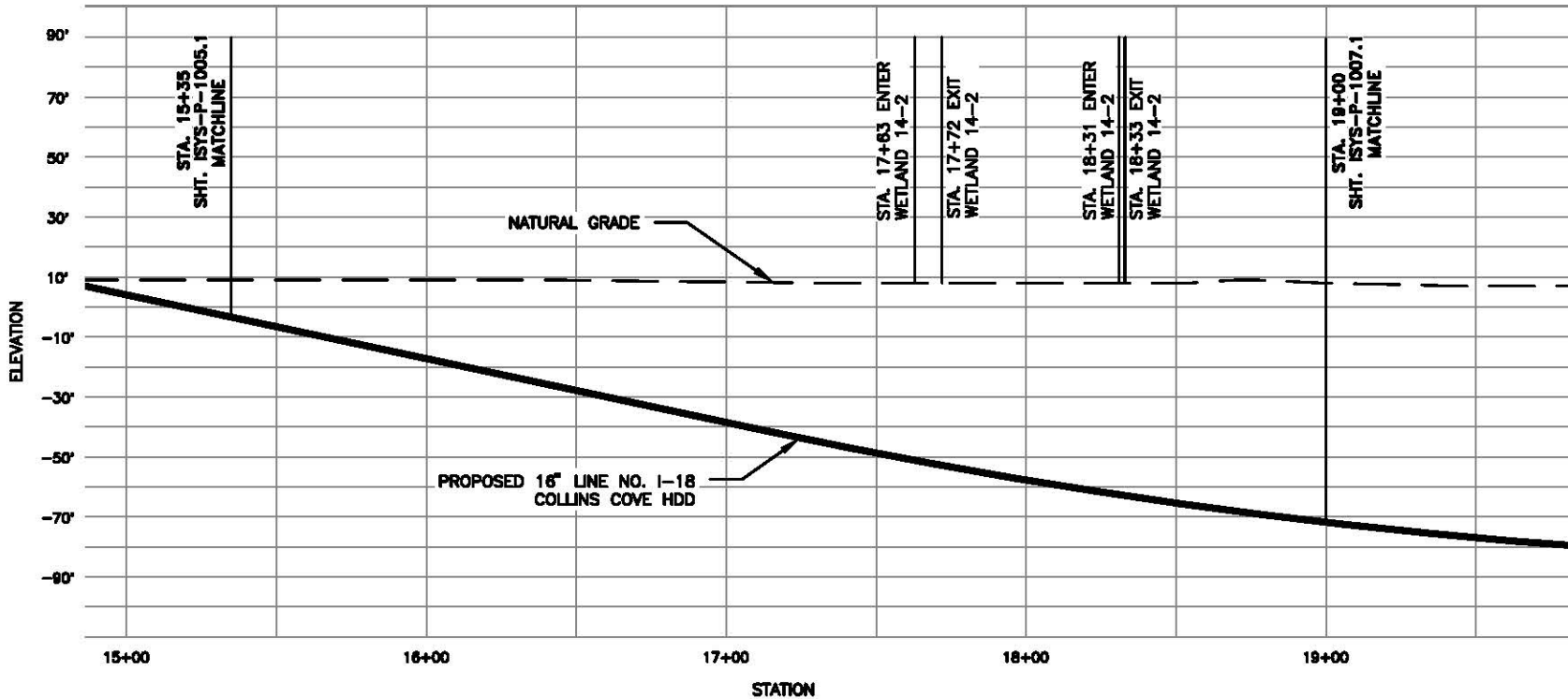

PROFILE SCALE:
1" = 60' HORIZ.
1" = 60' VERT.



**Hatch Mott
MacDonald**

150 LOWER WESTFIELD ROAD
HOLYOKE, MASSACHUSETTS 01040
PHONE (413) 535-0135
FAX (413) 535-0136

I-SYSTEM
SALEM LATERAL PROJECT
PROPOSED 16" LINE NO. I-18
USACE PERMIT DRAWING



Algonquin Gas Transmission, LLC
5400 Westheimer Ct. Houston, TX 77056-5310 713/627-5400

LOC.: ESSEX COUNTY, MASSACHUSETTS

DRN. BY: HMM

CKD. BY: HMM

ENG.:

DATE: 07/25/2014

SCALE: 1"=60'

DWG NO.: ISYS-P-1006.I

W.B.S.: CE.000064.001

SHT.: 11 OF 19

REV.:

P:\Spectra\Salem\lateral\DataProd\Work\Drafting\USACE_Details\USACE_Detail_7 - Plan.dwg

CITY OF SALEM
ESSEX COUNTY, MASSACHUSETTS

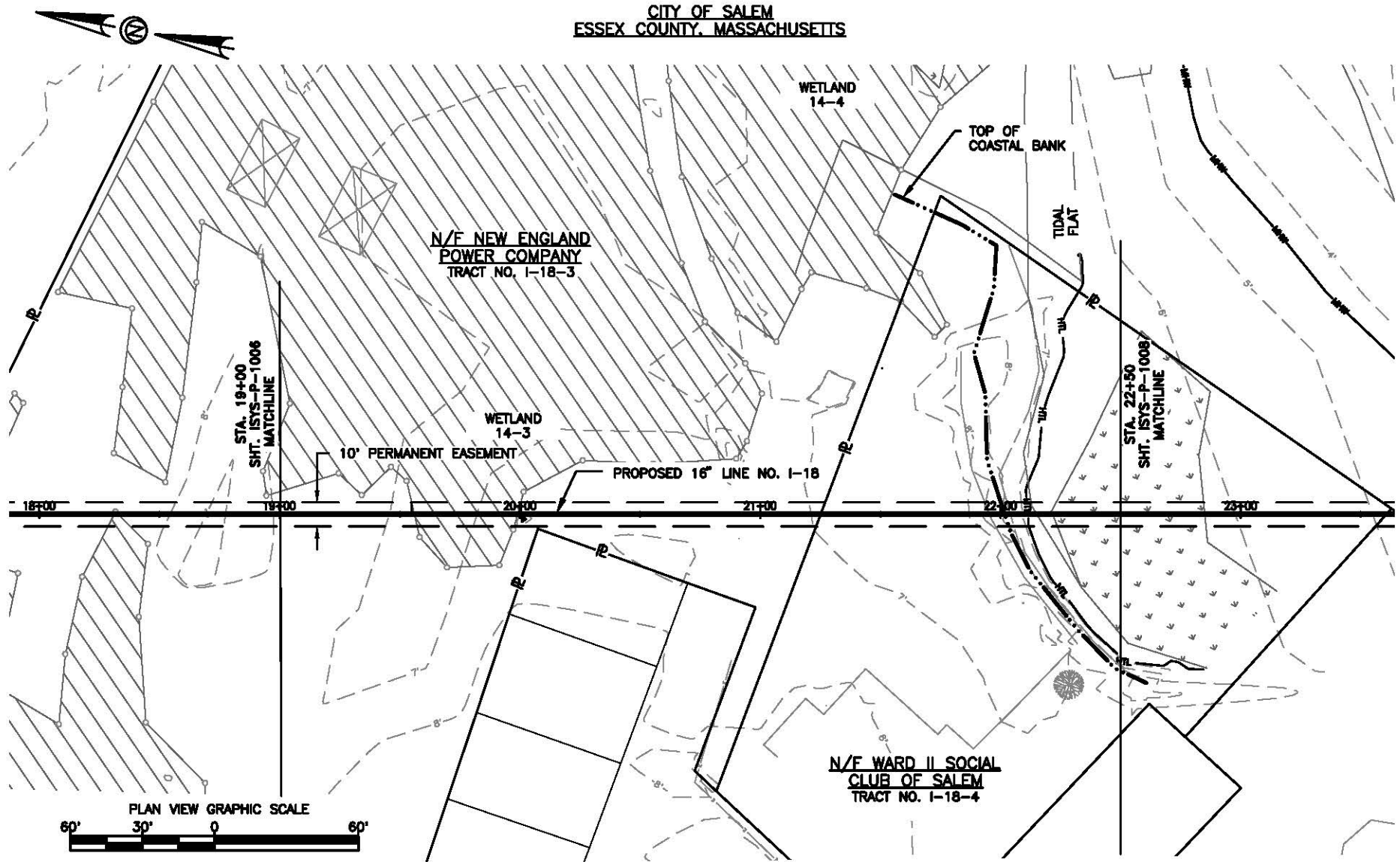

**Hatch Mott
MacDonald**

150 LOWER WESTFIELD ROAD
HOLYOKE, MASSACHUSETTS 01040
PHONE (413) 535-0135
FAX (413) 535-0136

I-SYSTEM
SALEM LATERAL PROJECT
PROPOSED 16" LINE NO. I-18
USACE PERMIT DRAWING



Algonquin Gas Transmission, LLC
5400 Westheimer Ct. Houston, TX 77056-5310 713/627-5400

LOC.: ESSEX COUNTY, MASSACHUSETTS

DRN. BY: HMM

DATE: 07/25/2014

W.B.S.: CE.000064.001

CKD. BY: HMM

SCALE: 1"=60'

SHT.: 12 OF 19

ENG.:

DWG NO.: ISYS-P-1007

REV.:

I.G.

CITY OF SALEM
ESSEX COUNTY, MASSACHUSETTS

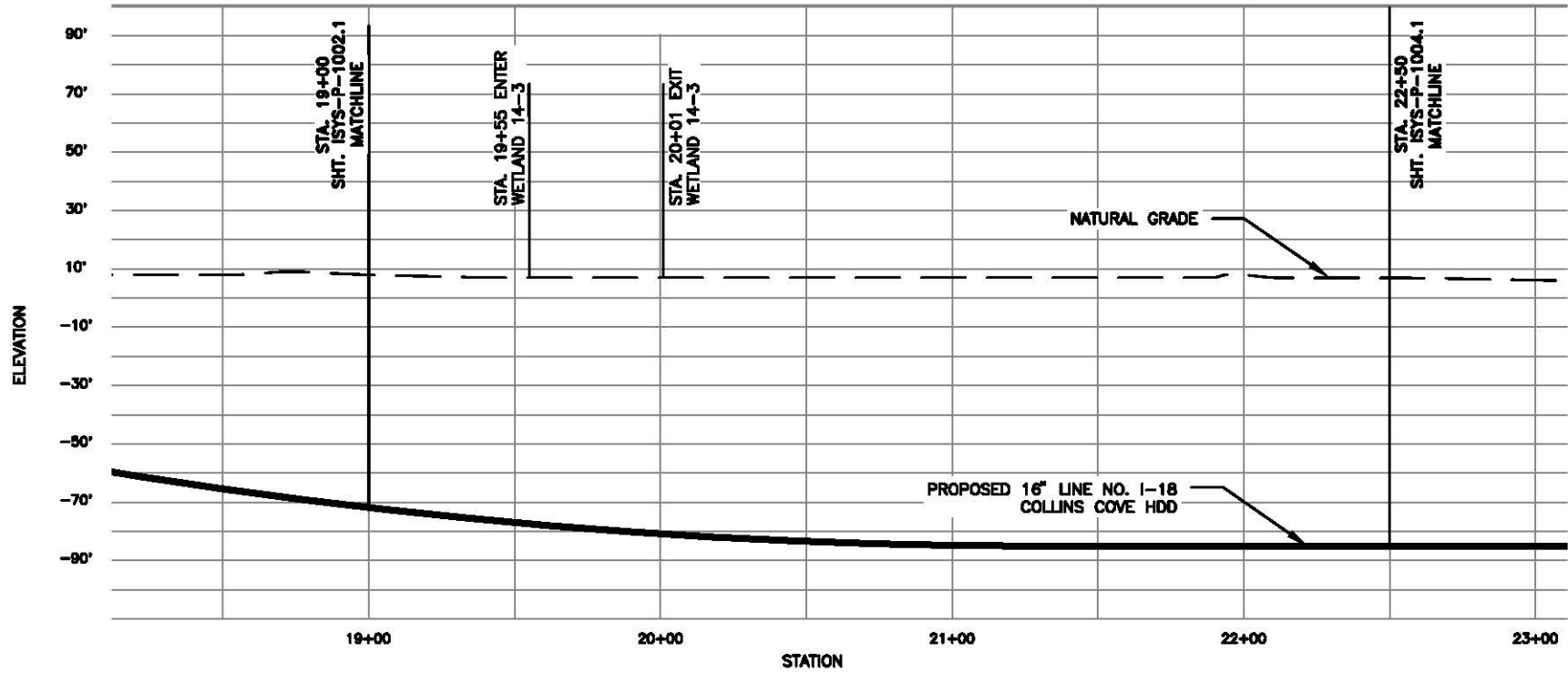

PROFILE SCALE:
1"=100' HORIZ.
1"=100' VERT.



**Hatch Mott
MacDonald**

150 LOWER WESTFIELD ROAD
HOLYOKE, MASSACHUSETTS 01040
PHONE (413) 535-0135
FAX (413) 535-0136

I-SYSTEM
SALEM LATERAL PROJECT
PROPOSED 16" LINE NO. 1-18
USACE PERMIT DRAWING



Algonquin Gas Transmission, LLC
5400 Westheimer Ct. Houston, TX 77056-5310 713/627-5400

LOC.: ESSEX COUNTY, MASSACHUSETTS

DRN. BY: HMM

DATE: 07/25/2014

W.B.S.: CE.000064.001

CKD. BY: HMM

SCALE: 1"=60'

SHT.: 13 OF 19

ENG.:

DWG NO.: ISYS-P-1007.1

REV.:

P:\Spectra\Salem\lateral\DataProd\Work\Drafting\USACE_Details\USACE_Detail_8 - Plan.dwg

I.G.

CITY OF SALEM
ESSEX COUNTY, MASSACHUSETTS

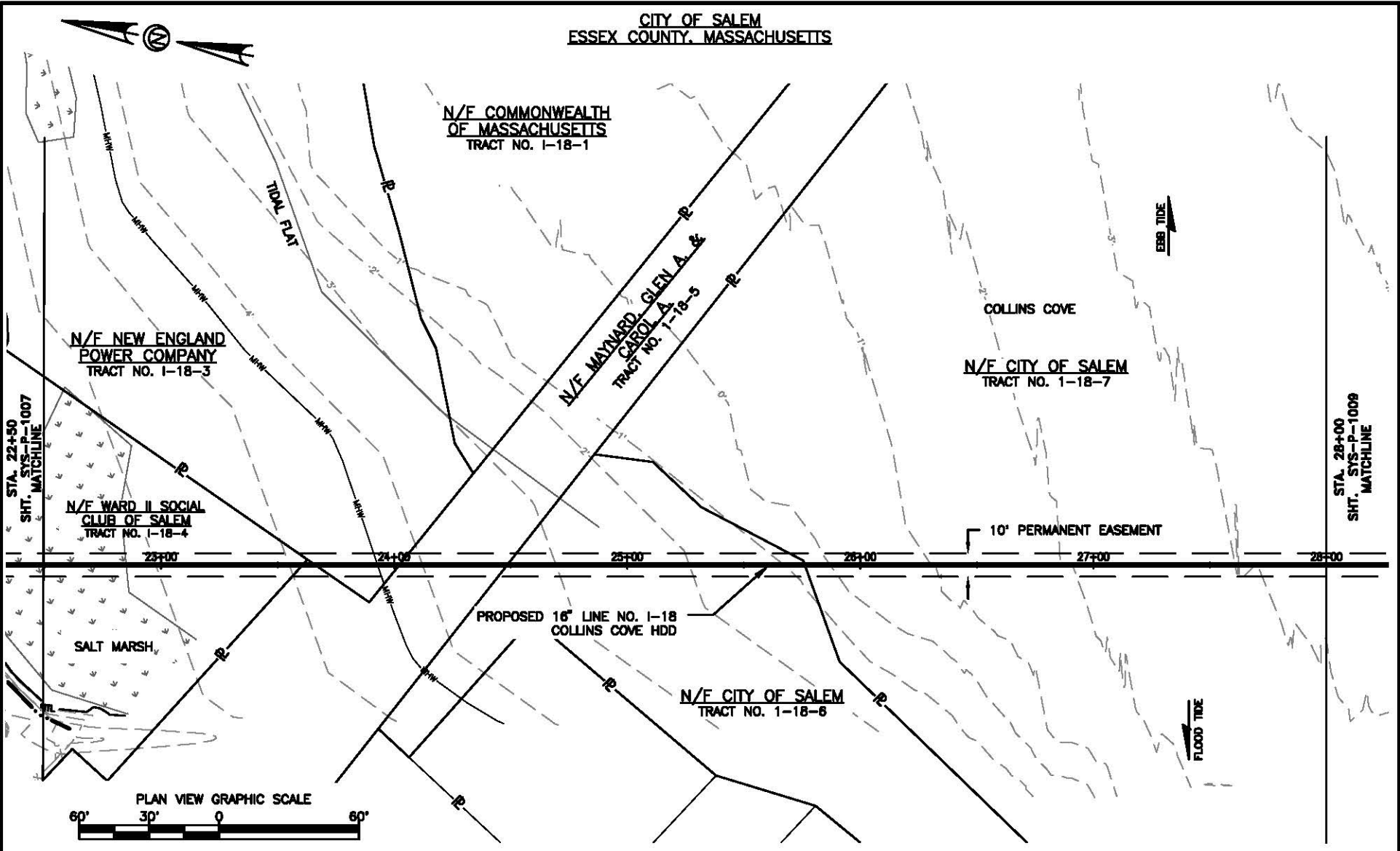

**Hatch Mott
MacDonald**

150 LOWER WESTFIELD ROAD
HOLYOKE, MASSACHUSETTS 01040
PHONE (413) 535-0135
FAX (413) 535-0136

I-SYSTEM
SALEM LATERAL PROJECT
PROPOSED 16" LINE NO. I-18
USACE PERMIT DRAWING



Algonquin Gas Transmission, LLC
5400 Westheimer Ct. Houston, TX 77056-5310 713/627-5400

LOC.: ESSEX COUNTY, MASSACHUSETTS

DRN. BY: HMM

CKD. BY: HMM

ENG.:

DATE: 07/25/2014 W.B.S.: CE.000064.001

SCALE: 1"=60' SHT.: 14 OF 19

DWG NO.: ISYS-P-1008

REV.:

CITY OF SALEM
ESSEX COUNTY, MASSACHUSETTS

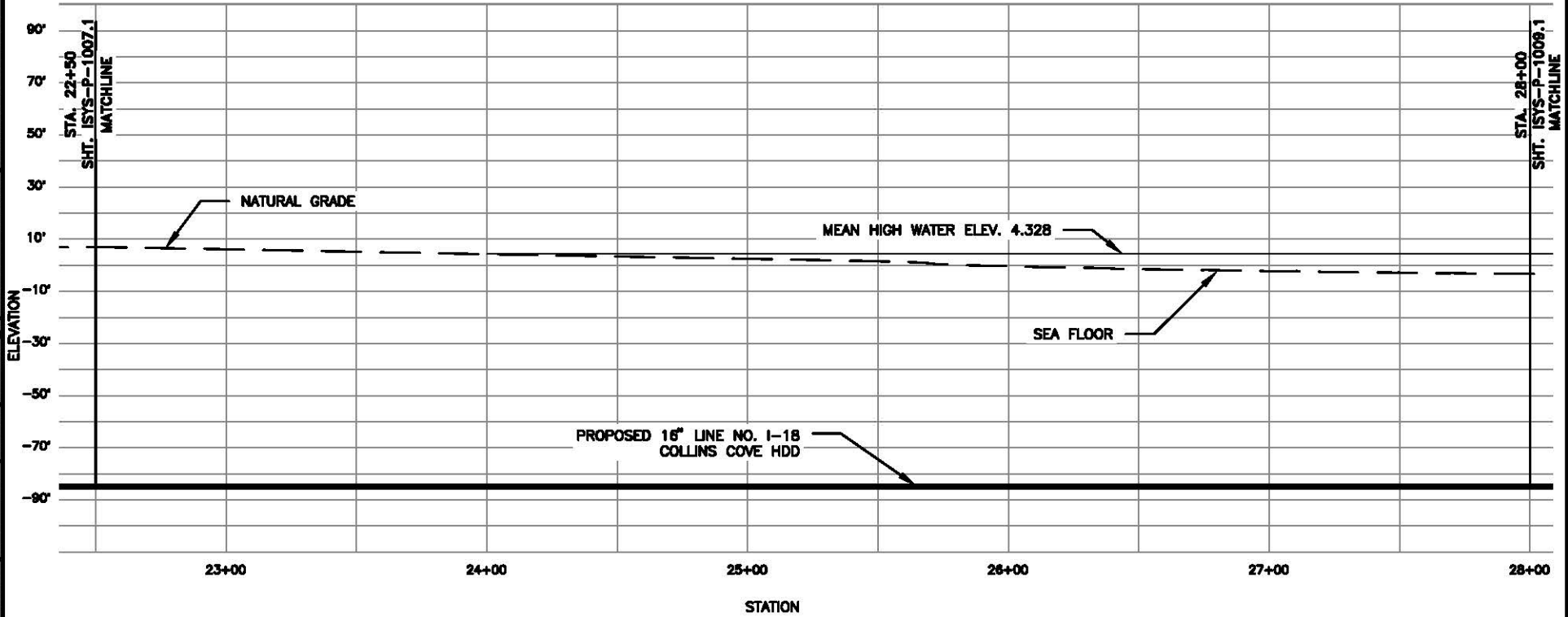

PROFILE SCALE:
1"=60' HORIZ.
1"=60' VERT.



**Hatch Mott
MacDonald**

150 LOWER WESTFIELD ROAD
HOLYOKE, MASSACHUSETTS 01040
PHONE (413) 535-0135
FAX (413) 535-0136

I-SYSTEM
SALEM LATERAL PROJECT
PROPOSED 16" LINE NO. I-18
USACE PERMIT DRAWING



Algonquin Gas Transmission, LLC
5400 Westheimer Ct. Houston, TX 77056-5310 713/627-5400

LOC.: ESSEX COUNTY, MASSACHUSETTS

DRN. BY: HMM

DATE: 07/25/2014

W.B.S.: CE.000064.001

CKD. BY: HMM

SCALE: 1"=60'

SHT.: 15 OF 19

ENG.:

DWG NO.: ISYS-P-1008.1

REV.:

CITY OF SALEM
ESSEX COUNTY, MASSACHUSETTS

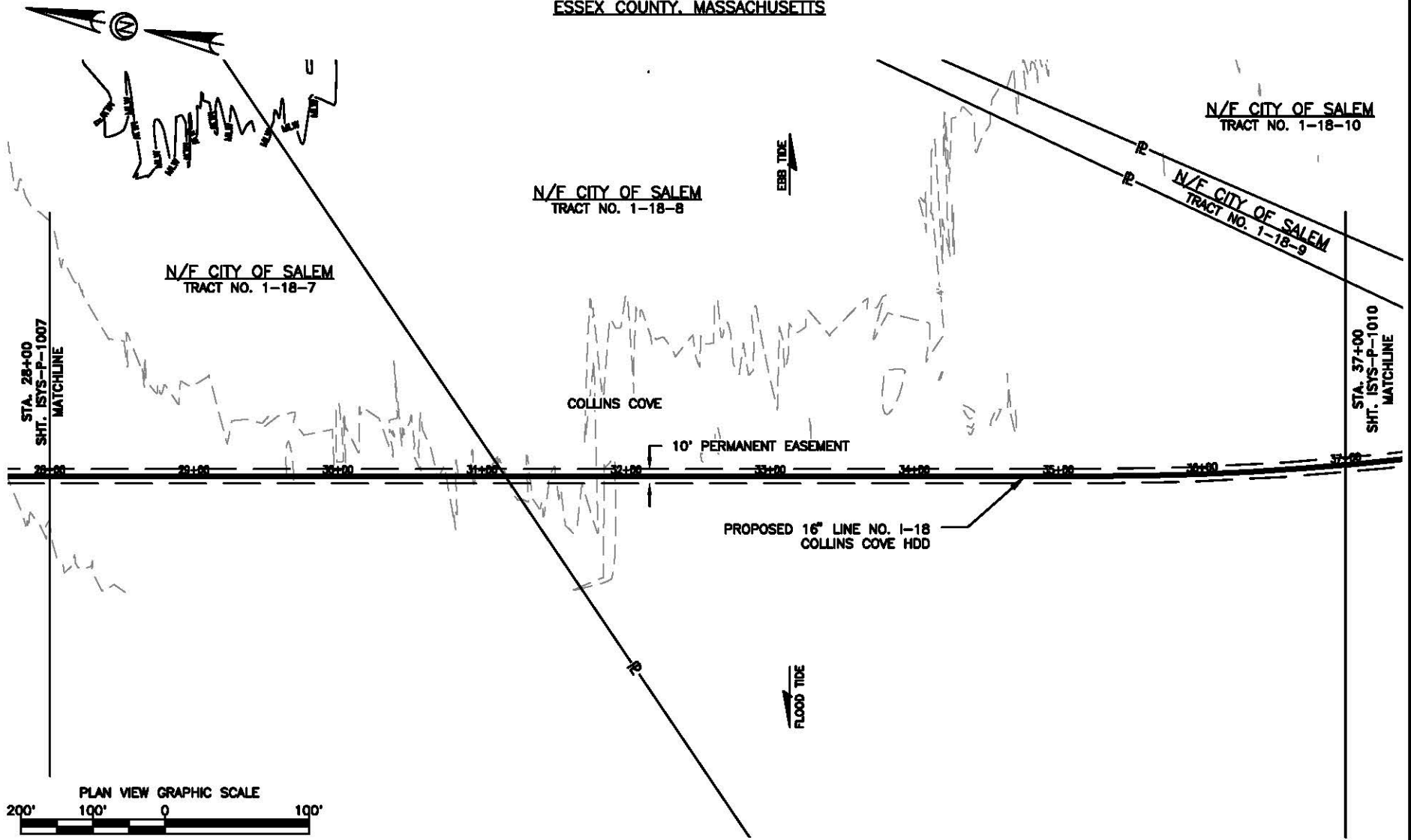

**Hatch Mott
MacDonald**

150 LOWER WESTFIELD ROAD
HOLYOKE, MASSACHUSETTS 01040
PHONE (413) 535-0135
FAX (413) 535-0136

I-SYSTEM
SALEM LATERAL PROJECT
PROPOSED 16" LINE NO. I-18
USACE PERMIT DRAWING



Algonquin Gas Transmission, LLC
5400 Westheimer Ct. Houston, TX 77056-5310 713/627-5400

LOC.: ESSEX COUNTY, MASSACHUSETTS

DRN. BY: HMM

CKD. BY: HMM

ENG.:

DATE: 07/25/2014

W.B.S.: CE.000064.001

SCALE: 1"=100'

SHT.: 16 OF 19

DWG NO.: ISYS-P-1009

REV.:

CITY OF SALEM
 ESSEX COUNTY, MASSACHUSETTS

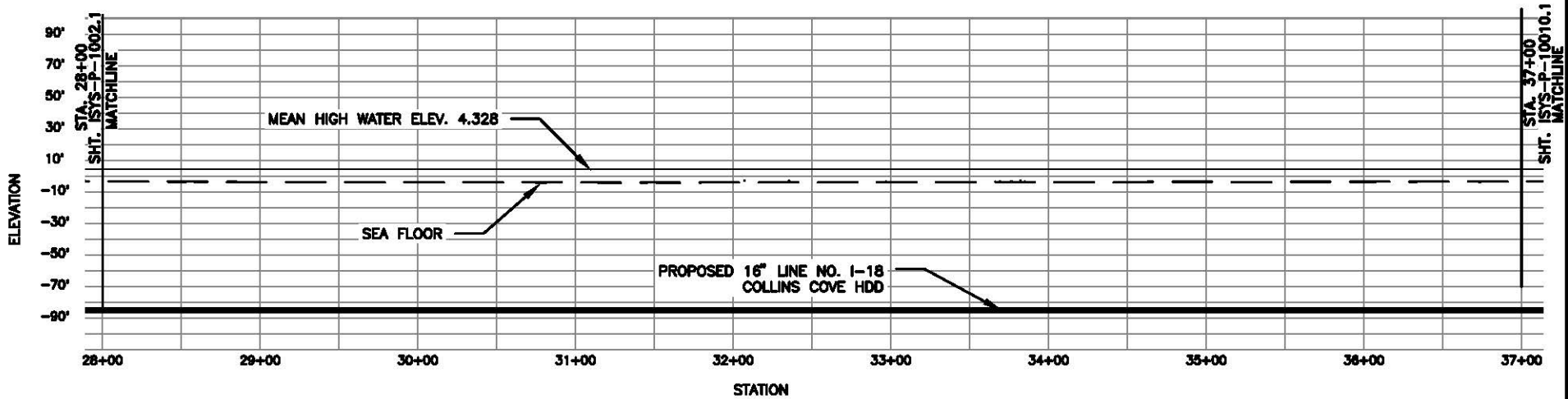

PROFILE SCALE:
 1" = 100' HORIZ.
 1" = 100' VERT.



**Hatch Mott
 MacDonald**

150 LOWER WESTFIELD ROAD
 HOLYOKE, MASSACHUSETTS 01040
 PHONE (413) 535-0135
 FAX (413) 535-0136

I-SYSTEM
 SALEM LATERAL PROJECT
 PROPOSED 16" LINE NO. I-18
 USACE PERMIT DRAWING



Algonquin Gas Transmission, LLC
 5400 Westheimer Ct. Houston, TX 77056-5310 713/627-5400

LOC.: ESSEX COUNTY, MASSACHUSETTS

DRN. BY: HMM

CKD. BY: HMM

ENG.:

DATE: 07/25/2014

W.B.S.: CE.000064.001

SCALE: 1"=100'

SHT.: 17 OF 19

DWG NO.: ISYS-P-1009.1

REV.:

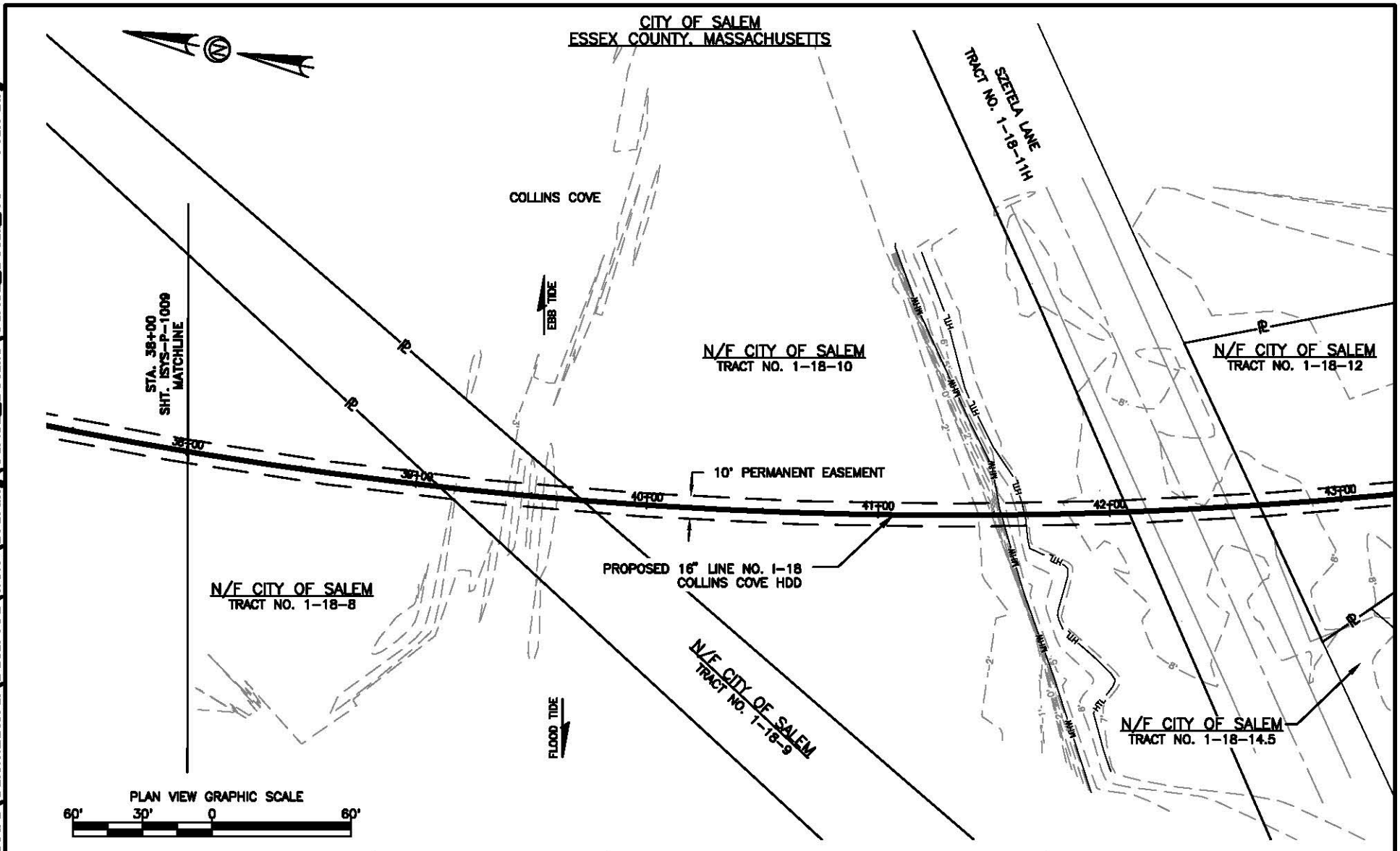

**Hatch Mott
MacDonald**

150 LOWER WESTFIELD ROAD
HOLYOKE, MASSACHUSETTS 01040
PHONE (413) 535-0135
FAX (413) 535-0136

I-SYSTEM
SALEM LATERAL PROJECT
PROPOSED 16" LINE NO. I-18
USACE PERMIT DRAWING



Algonquin Gas Transmission, LLC
5400 Westheimer Ct. Houston, TX 77056-5310 713/627-5400

LOC.: ESSEX COUNTY, MASSACHUSETTS

DRN. BY: HMM

CKD. BY: HMM

ENG.:

DATE: 07/25/2014

SCALE: 1"=60'

DWG NO.: ISYS-P-1010

W.B.S.: CE.000064.001

ISHT.: 18 OF 19

REV.:

P:\Spectra\Salem\Laterals\DataProd\Work\Drafting\USACE_Details\USACE_Detail_10 - Plan.dwg

CITY OF SALEM
 ESSEX COUNTY, MASSACHUSETTS

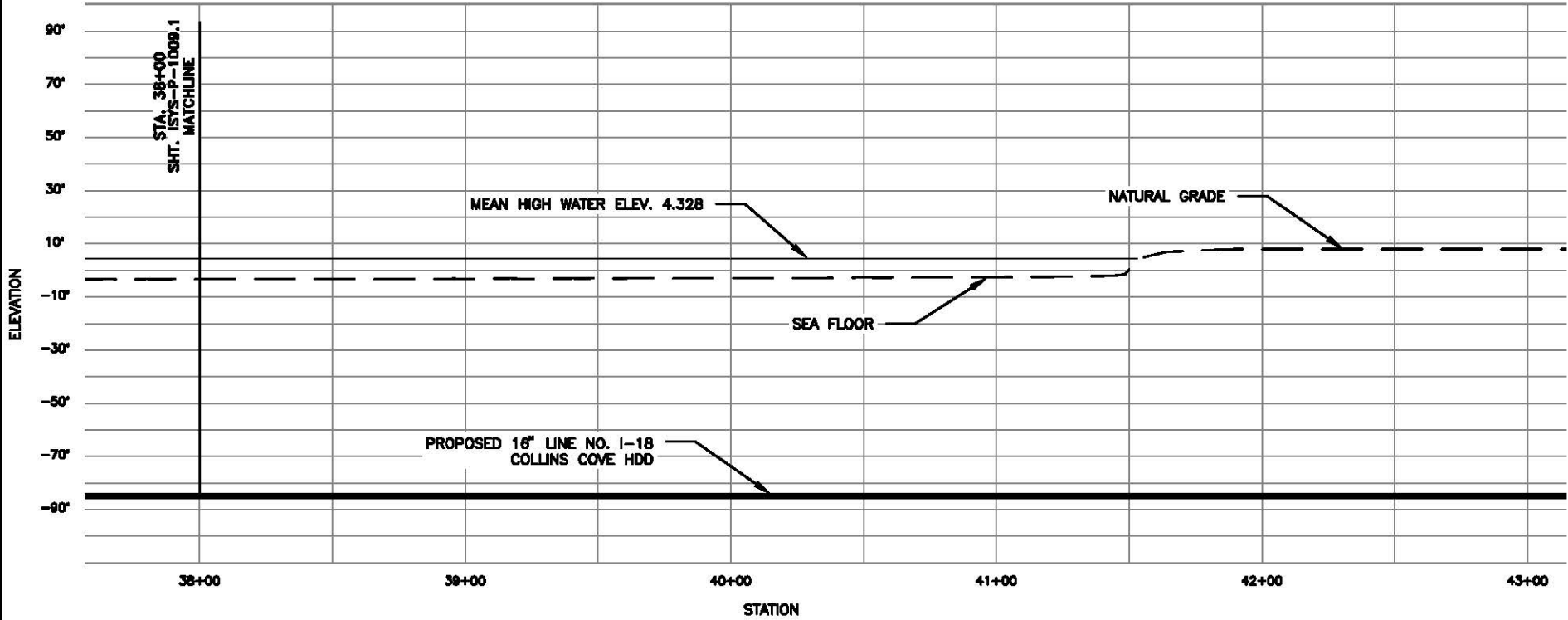

PROFILE SCALE:
 1"=60' HORIZ.
 1"=80' VERT.



**Hatch Mott
 MacDonald**

150 LOWER WESTFIELD ROAD
 HOLYOKE, MASSACHUSETTS 01040
 PHONE (413) 535-0135
 FAX (413) 535-0136

I-SYSTEM
 SALEM LATERAL PROJECT
 PROPOSED 16" LINE NO. I-18
 USACE PERMIT DRAWING



Algonquin Gas Transmission, LLC
 5400 Westheimer Ct. Houston, TX 77056-5310 713/627-5400

LOC.: ESSEX COUNTY, MASSACHUSETTS

DRN. BY: HMM

DATE: 07/25/2014

W.B.S.: CE.000064.001

CKD. BY: HMM

SCALE: 1"=60'

SHT.: 19 OF 19

ENG.:

DWG NO.: 1SYS-P-1010.1

REV.:

I.G.

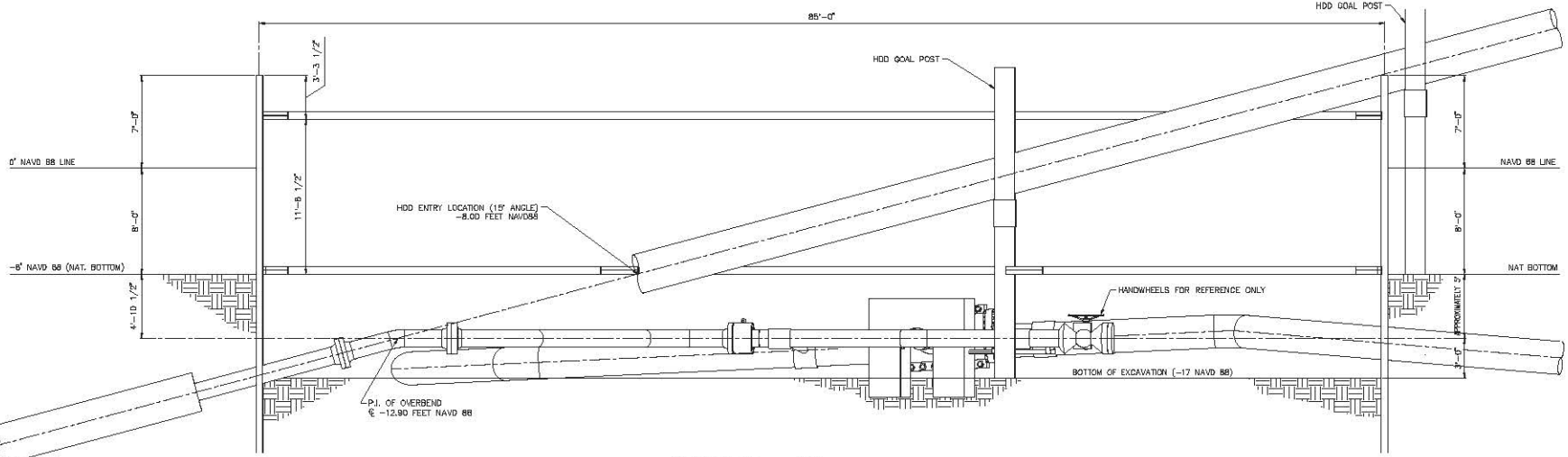

SECTION A
SCALE: 1/4" = 1'-0" LAYOUT

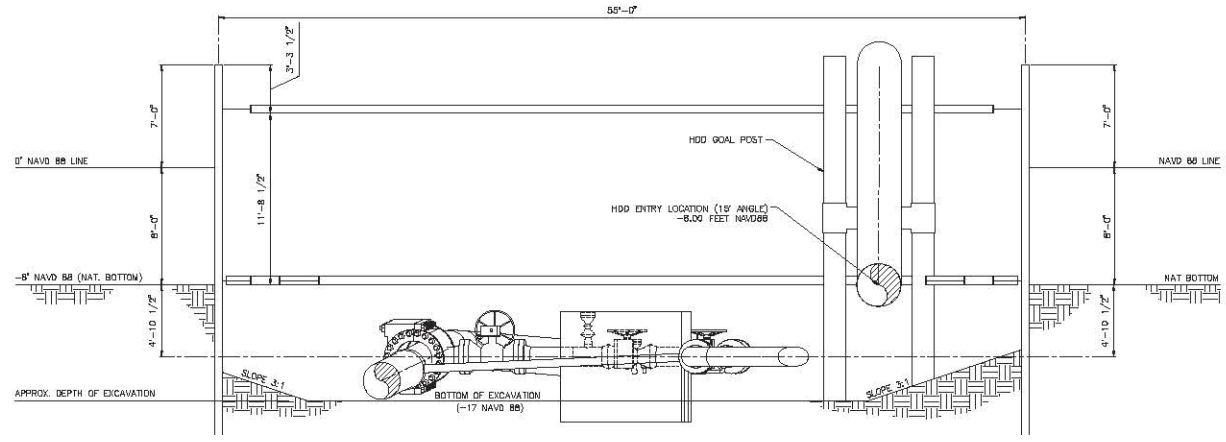

SECTION B
SCALE: 1/4" = 1'-0" LAYOUT

PRELIMINARY, NOT FOR CONSTRUCTION

0	HATCH MOTT MACDONALD SOIL BORING LOGS					
0	QSI HYDROGRAPH AND MAGNETOMETER SURVEY					
DWS. NO.	REFERENCE DWG.	REV	DSN	CK	DESCRIPTION	



ENGINEERING APPROVALS					
DRAWN BY	ADJ	BID	CONSTRUCTION		
TITLE	SIGNATURE	DATE	SIGNATURE	DATE	

I-SYSTEM
SALEM LATERAL PROJECT
PROPOSED 16" LINE NO. 1-18
SECTIONS
LOC. BEVERLY HARBOR
YEAR: 2014 W.O. 3500003116 SCALE: AS NOTED

Spectra Energy Partners.
Algebra (Geo) Transmission, LLC
3600 Westside Dr. Houston, TX 77056-3617 / 62-366

DWG. ISYS-Z-3000 REV. A

**Figure 3.2-2
Offshore Cofferdam and HDD Workspace Layout in Beverly Harbor (Typical)**

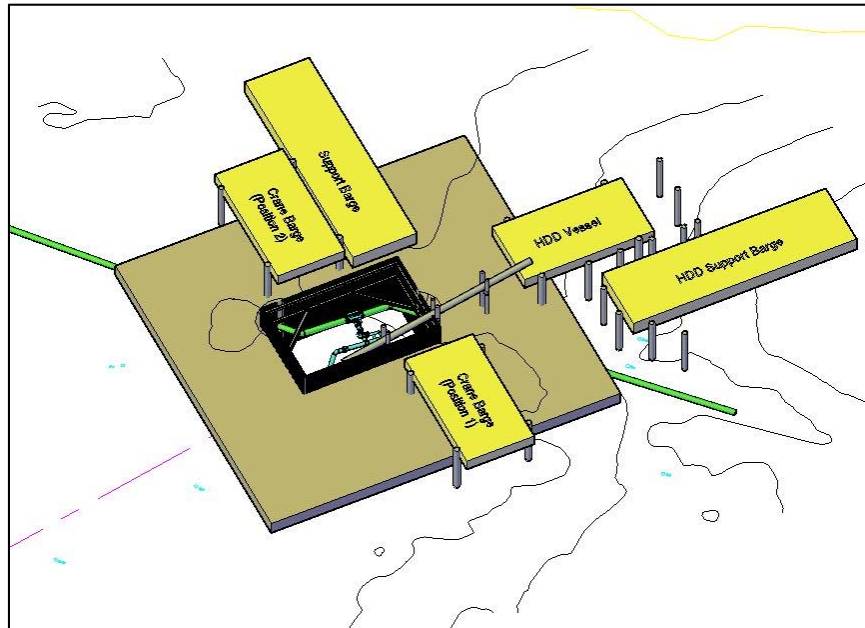

As previously described, the cofferdam sheet piling cannot be hammered in at the two locations where the existing HubLine pipeline will cross into and out of the cofferdam area. As such, two gaps will be built into the cofferdam walls. In addition, the buried end of the HDD casing pipe will be located within the cofferdam but it must be extended out through a third gap in the cofferdam wall to reach the HDD support vessel stationed outside of the cofferdam. To provide turbidity containment at these three openings in the cofferdam walls, Algonquin will install an alternative sheeting material that does not affect the integrity of the existing HubLine pipeline or HDD casing pipe, but does allow the water level to fluctuate with the ambient conditions and provide containment for a majority of the suspended sediments. The alternate material will consist of a geotextile fabric sheeting that is attached to wooden slats in the openings. The geotextile fabric will limit the size of particles that can pass through the openings yet will allow sufficient water flow to ensure the elevation of the water depth within the cofferdam is equal to the exterior of the cofferdam. A woven geotextile fabric is commonly used for silt curtains and may be used for this application. This fabric can typically pass approximately 18 gallons per minute per square foot of fabric while limiting particle sizes to 70 sieve and above. Figure 3.2-3 shows a typical view of one of the openings in the cofferdam where the existing HubLine pipeline would pass through.

The angle of the installation of the HDD does not allow for the HDD casing to be completely enclosed within the cofferdam without increasing the length of the cofferdam by approximately 25 feet, which would also increase the environmental disturbance from the size and duration of installation. To address this issue, Algonquin will install the HDD casing into the bedrock to minimize the potential for inadvertent returns outside of the cofferdam. Algonquin proposes to install the HDD casing first and then build the cofferdam around it. The cofferdam will potentially provide support for the HDD casing or allow secondary bracing between the HDD casing and the cofferdam. On the west end of the cofferdam, where the HDD casing enters the mudline, the sheet pile can be installed so that it rests on bottom with very little penetration.